

# Housing - HC-STA-D15-HHFS-1TTP16-ELC-AL - 1424353

Please be informed that the data shown in this PDF Document is generated from our Online Catalog. Please find the complete data in the user's documentation. Our General Terms of Use for Downloads are valid (<http://phoenixcontact.com/download>)



Sleeve housing D15, for single locking latch, material: Die-cast aluminum, salt water resistant, cable outlets: 1, straight, height: 68 mm, cable gland: none, support sleeve: no, 1x Pg16, Standard



## Key Commercial Data

|              |               |
|--------------|---------------|
| Packing unit | 1 pc          |
| GTIN         |               |
| GTIN         | 4055626370897 |

## Technical data

### Dimensions

|        |         |
|--------|---------|
| Height | 68 mm   |
| Width  | 30 mm   |
| Length | 63.5 mm |

### Ambient conditions

|                                 |                   |
|---------------------------------|-------------------|
| Degree of protection (IP)       | IP66              |
|                                 | IP67              |
| Ambient temperature (operation) | -40 °C ... 125 °C |

### General

|                              |                                 |
|------------------------------|---------------------------------|
| Note                         | For contact inserts HC-D15, A10 |
| Size                         | D15                             |
| Housing type                 | Sleeve housing                  |
| Color                        | gray aluminum                   |
| Locking type                 | for single locking latch        |
| No. of cable outlets         | 1                               |
| Cable outlet                 | straight                        |
| Screw connection             | none                            |
| Type of the screw connection | 1x Pg16                         |

# Housing - HC-STA-D15-HHFS-1TTP16-ELC-AL - 1424353

## Technical data

### General

|                          |   |
|--------------------------|---|
| Housing material         | Die-cast aluminum, salt water resistant |
| Housing surface material | uncoated                                |
| Seal material            | NBR, conductive                         |

### Environmental Product Compliance

|            |   |
|------------|---|
| China RoHS | Environmentally Friendly Use Period = 50  |
|            | For details about hazardous substances go to tab "Downloads", Category "Manufacturer's declaration" |

## Drawings

Dimensional drawing

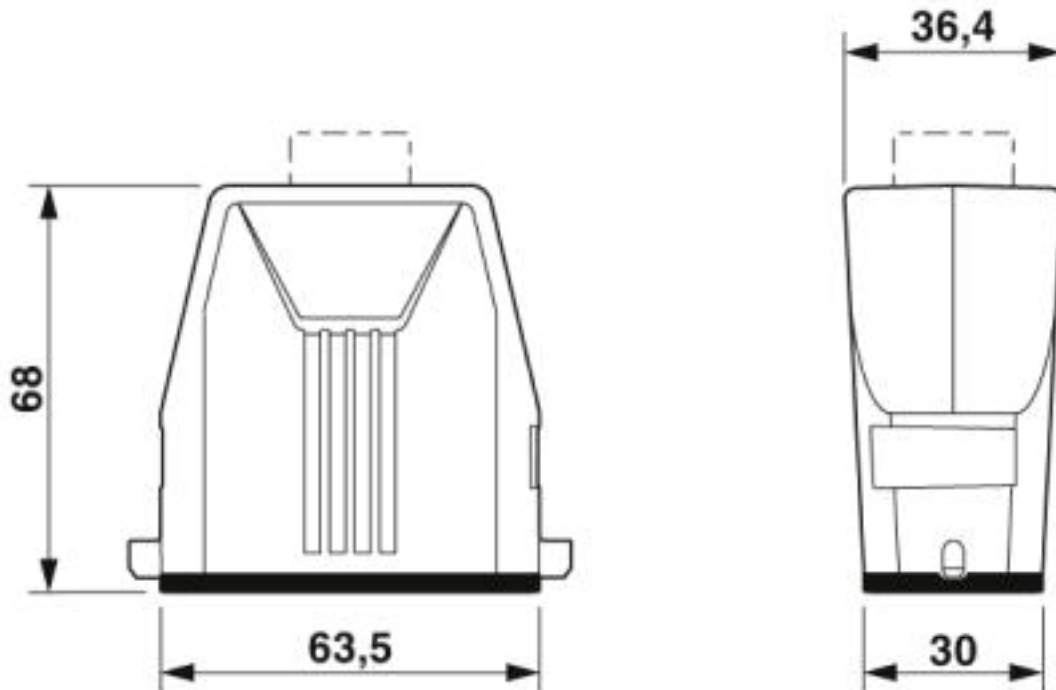

Dimensional drawing

## Approvals

### Approvals

### Approvals

EAC / UL Recognized / cUL Recognized / DNV GL / cULus Recognized

### Ex Approvals

# Housing - HC-STA-D15-HHFS-1TTP16-ELC-AL - 1424353

## Approvals

### Approval details

|                  |  |   |               |
|------------------|--|---|---------------|
| EAC              |  |   | EAC-Zulassung |
| UL Recognized    |  | <a href="http://database.ul.com/cgi-bin/XYV/template/LISEXT/1FRAME/index.htm">http://database.ul.com/cgi-bin/XYV/template/LISEXT/1FRAME/index.htm</a> | E255026       |
| cUL Recognized   |  | <a href="http://database.ul.com/cgi-bin/XYV/template/LISEXT/1FRAME/index.htm">http://database.ul.com/cgi-bin/XYV/template/LISEXT/1FRAME/index.htm</a> | E255026       |
| DNV GL           |  | <a href="https://approvalfinder.dnvgl.com/">https://approvalfinder.dnvgl.com/</a>   | TAE000037S    |
| cULus Recognized |  |   |               |

Phoenix Contact 2019 © - all rights reserved  
<http://www.phoenixcontact.com>

PHOENIX CONTACT GmbH & Co. KG  
Flachsmarktstr. 8  
32825 Blomberg  
Germany  
Tel. +49 5235 300  
Fax +49 5235 3 41200  
<http://www.phoenixcontact.com>