

Jul.1.2019 Copyright 2019 HIROSE ELECTRIC CO., LTD. All Rights Reserved.  
In case of consideration for using Automotive equipment / device which demand high reliability, kindly contact our sales window correspondents.

COUNT	DESCRIPTION OF REVISIONS	B	Y	CHKD	DATE	COUNT	DESCRIPTION OF REVISIONS	B	Y	CHKD	DATE
3	RE-6-0649	J.S.H	J.H.W		16. 05. 04						
3	RE-6-0774	J.S.H	J.H.W		16. 11. 07						

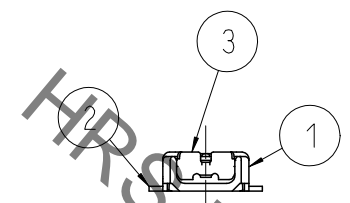

ENGAGEMENT FIGURE (50:1)

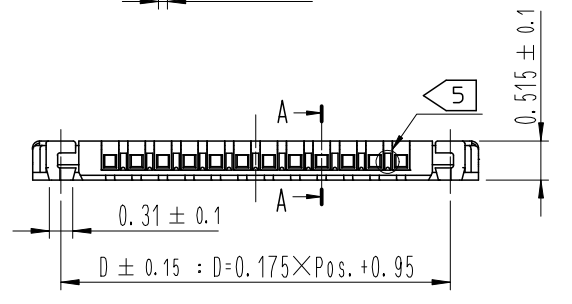
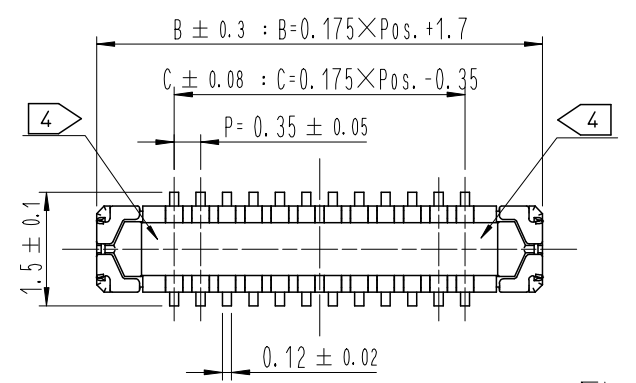
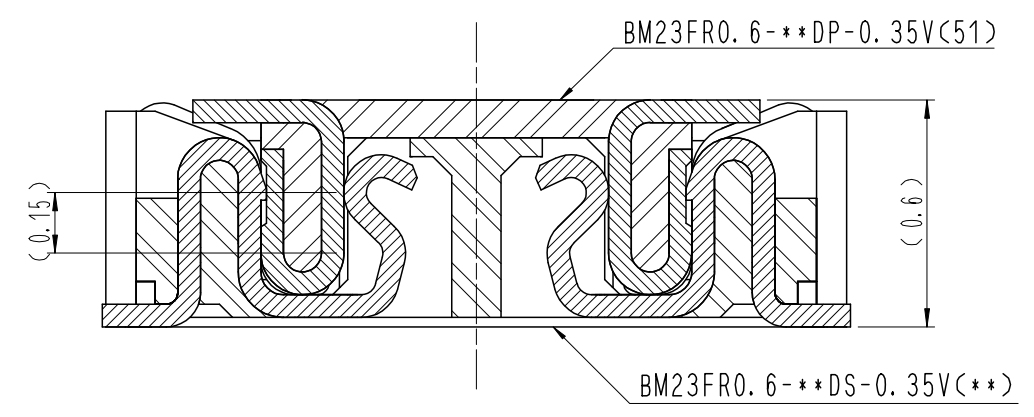

DRAWING FOR REFERENCE  
This is subject to change without notice

A-A (50:1)

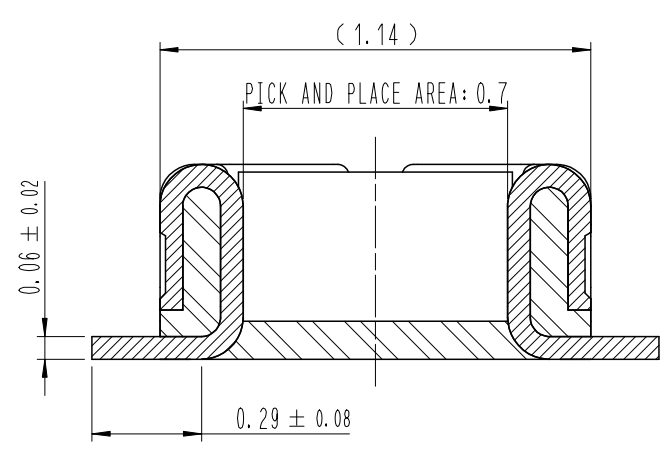

△ PART No.	CODE No.	POS.	B	C	D
BM23FR0.6-6DP-0.35V(51)	-	6	2.75	0.70	2.00
BM23FR0.6-8DP-0.35V(51)	-	8	3.10	1.05	2.35
BM23FR0.6-10DP-0.35V(51)	-	10	3.45	1.40	2.70
BM23FR0.6-12DP-0.35V(51)	-	12	3.80	1.75	3.05
BM23FR0.6-16DP-0.35V(51)	-	16	4.50	2.45	3.75
BM23FR0.6-20DP-0.35V(51)	-	20	5.20	3.15	4.45
BM23FR0.6-24DP-0.35V(51)	-	24	5.90	3.85	5.15
BM23FR0.6-30DP-0.35V(51)	-	30	6.95	4.90	6.20
BM23FR0.6-34DP-0.35V(51)	-	34	7.65	5.60	6.90
BM23FR0.6-40DP-0.35V(51)	-	40	8.70	6.65	7.95
BM23FR0.6-50DP-0.35V(51)	-	50	10.45	8.40	9.70

- NOTE
- 1. ALL LEAD CO-PLANARITY SHALL BE 0.08mm MAX.
  - 2. CONTACT PLATING SPECIFICATIONS.  
CONTACT AREA : GOLD 0.05 μm MIN.  
SMT LEAD : GOLD 0.05 μm MIN.  
UNDER PLATING : NICKEL 1 μm MIN.  
( SURFACE : SEALING )
  - 3. METAL FITTING PLATING SPECIFICATIONS.  
SMT LEAD : GOLD 0.05 μm MIN.  
UNDERPLATING : NICKEL 1 μm MIN.  
( SURFACE : SEALING )
  - 4. CAV No. IS INDICATED IN APPROX POSITION SHOWN.
  - 5. A PART OF THE WALL COULD BE NOTCHED.

4	PS	CLEAR (EMBOSSED CARRIER TAPE)			
3	PHOSPHOR BRONZE	3	7	PS	CLEAR (REINFORCEMENT COLLAR)
2	PHOSPHOR BRONZE	2	6	PS	BLACK (PLASTIC REEL)
1	LCP	UL94 V-0, BLACK	5	POLYESTER	CLEAR (COVER TAPE)
NO.	MATERIAL	FINISH, REMARKS	NO.	MATERIAL	FINISH, REMARKS
REMARKS			DRAWN	DESIGNED	CHECKED
			D. W. KIM	D. W. KIM	H. W. JO
			14. 11. 06	14. 11. 06	14. 11. 06
			APPROVED	RELEASED	
			T. S. KANG		16. 11. 07
CODE NO. (OLD)	DRAWING NO. EDC3-*****		PART NO. BM23FR0.6-**-DP-0.35V(51)		
SCALE 10:1	HRS HIROSE KOREA CO., LTD.		CODE NO	CL 66**-*****-***	
UNITS mm				1/3	

Jul.1.2019 Copyright 2019 HIROSE ELECTRIC CO., LTD. All Rights Reserved.  
In case of consideration for using Automotive equipment / device which demand high reliability, kindly contact our sales window correspondents.

7 RECOMMENDED PCB LAYOUT

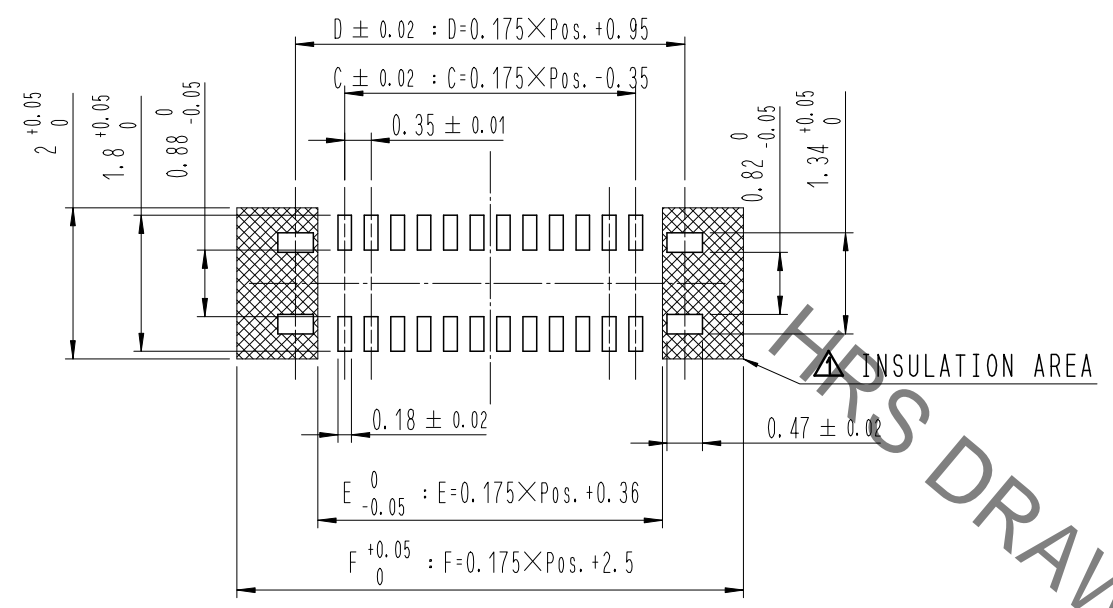

RECOMMENDED METAL MASK DIMENSIONS

METAL MASK THICKNESS : 100 μm

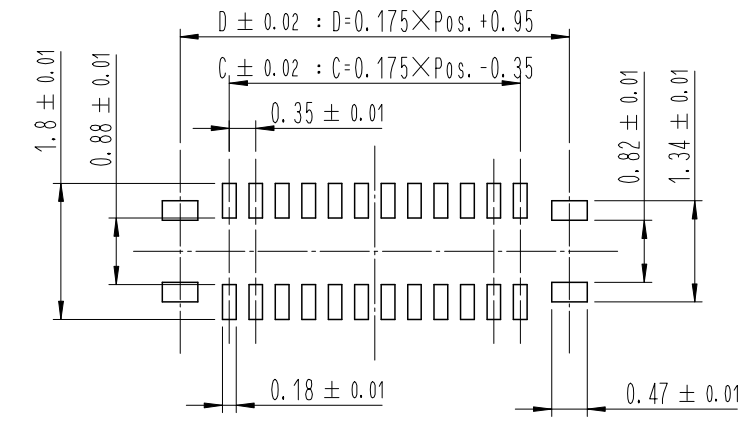

POS.	C	D	E	F
6	0.70	2.00	1.41	3.55
8	1.05	2.35	1.76	3.90
10	1.40	2.70	2.11	4.25
12	1.75	3.05	2.46	4.60
16	2.45	3.75	3.16	5.30
20	3.15	4.45	3.86	6.00
24	3.85	5.15	4.56	6.70
30	4.90	6.20	5.61	7.75
34	5.60	6.90	6.31	8.45
40	6.65	7.95	7.36	9.50
50	8.40	9.70	9.11	11.25

6 RECOMMENDED REFLOW TEMPERATURE PROFILE USING LEAD-FREE SOLDER PASTE.

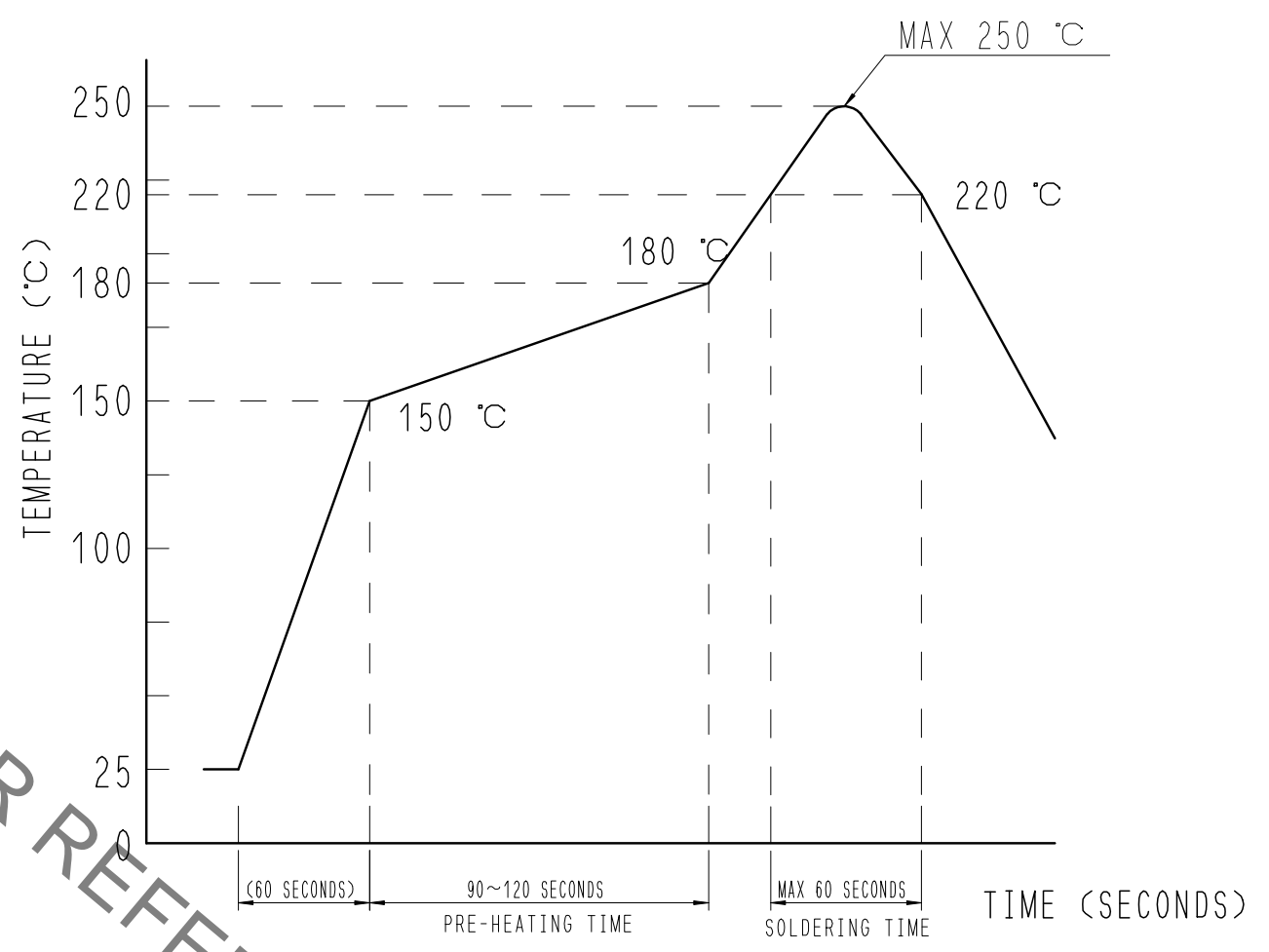

REFLOW METHOD: IR REFLOW  
 NUMBER OF REFLOW CYCLES: 2 CYCLES MAX.  
 1) REFLOW TIME  
 DURATION ABOVE 220°C, 60 SEC MAX.  
 (PEAK TEMPERATURE: 250°C MAX)  
 2) PRE-HEAT TIME  
 PRE-HEAT TEMPERATURE(MIN): 150°C  
 PRE-HEAT TEMPERATURE(MAX): 180°C  
 PRE-HEAT TIME: 90-120 SEC.

6 THIS TEMPERATURE PROFILE IS PER THE CONDITIONS SHOWN ABOVE. ADDITIONAL FACTORS, SUCH AS SOLDER PASTE TYPE, PCB SIZE AND OTHER MOUNTED COMPONENTS COULD AFFECT THE PROFILE. THEREFORE, A THOROUGH EVALUATION OF MOUNTING CONDITION IS REQUIRED PRIOR TO PRODUCTION. TEMPERATURE IS MEASURED AT CONTACT LEAD.

7 PLEASE CONTACT US IN CASE YOU WILL MAKE DIFFERENT SETTINGS FROM OUR RECOMMENDATION.

 SCALE 10:1 UNITS mm	DRAWING NO. EDC3-*****	PART NO. BM23FR0.6-***DP-0.35V(51)
	HIROSE KOREA CO., LTD.	CODE NO CL 66**-*****-***

Jul.1.2019 Copyright 2019 HIROSE ELECTRIC CO., LTD. All Rights Reserved.  
 In case of consideration for using Automotive equipment / device which demand high reliability, kindly contact our sales window correspondents.

# EMBOSED CARRIER TAPE PACKAGING (5:1)

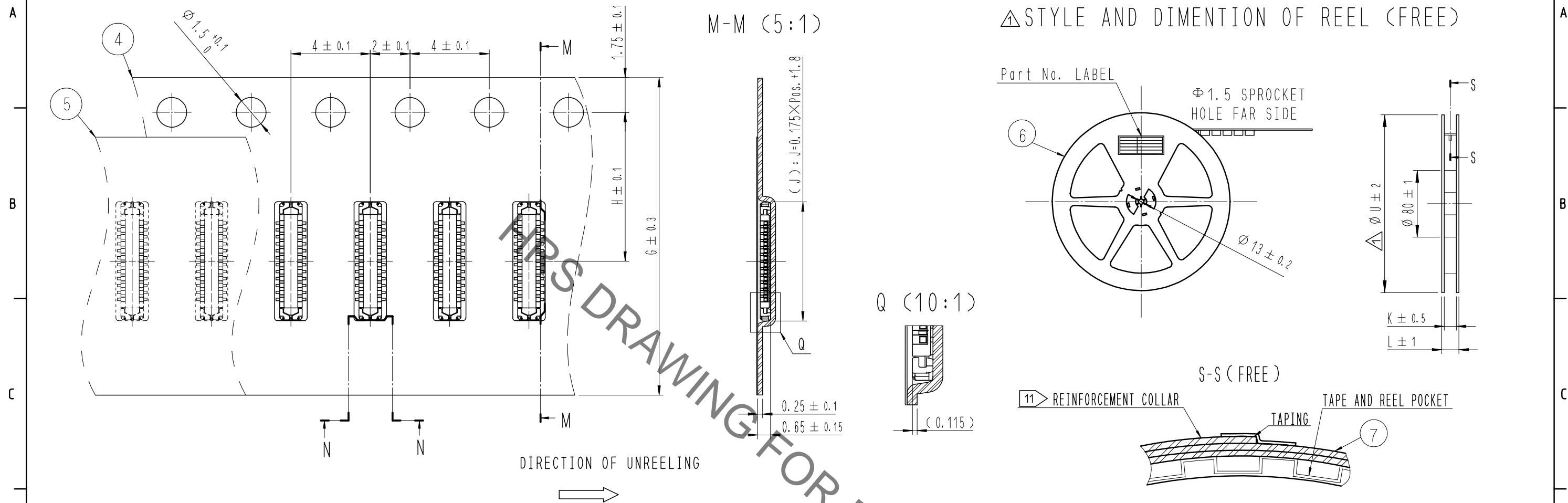

DIRECTION OF UNREELING →

## N-N (5:1)

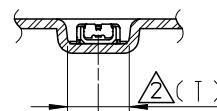

△ POS.	G	H	J	K	L	T	U
6	12	5.5	2.85	13.5	17.5	1.58	330
8	12	5.5	3.20	13.5	17.5	1.58	330
10	12	5.5	3.55	13.5	17.5	1.64	380
12	12	5.5	3.90	13.5	17.5	1.64	330
16	16	7.5	4.60	17.5	21.5	1.64	330
20	16	7.5	5.30	17.5	21.5	1.64	380
24	16	7.5	6.00	17.5	21.5	1.64	380
30	16	7.5	7.05	17.5	21.5	1.64	330
34	16	7.5	7.75	17.5	21.5	1.64	380
40	24	11.5	8.80	25.5	29.5	1.64	330
50	24	11.5	10.55	25.5	29.5	1.64	330

## DETAIL OF PART No. LABEL

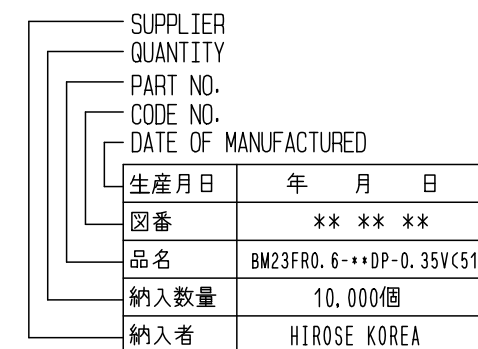

## 10 TAPING(FREE)

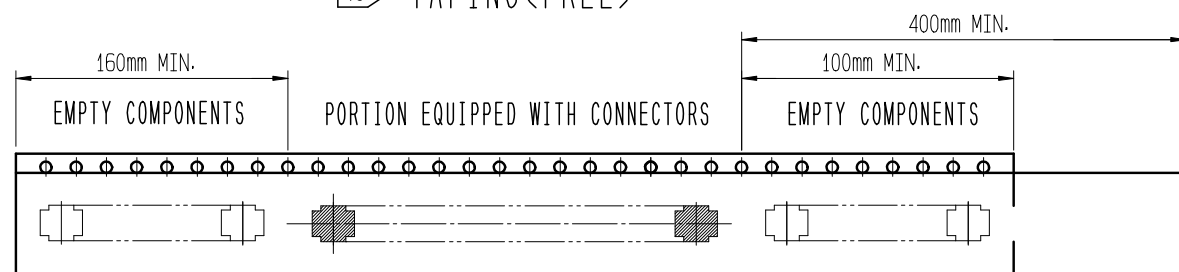

8 . PER REEL 10,000 CONNECTORS.

9 . THE DIMENSIONS IN PARENTHESES ARE FOR REFERENCE.

10 REFER TO JIS C 0806, IEC-60286-3 (PACKAGING OF COMPONENTS FOR AUTOMATIC HANDLING)

11 AFTER PACKAGING, ROLL 2 METERS OF THE REINFORCEMENT COLLAR TO OUTER CIRCUMFERENCE OF TAPE AND REEL POCKET. AND TAPE DOWN AT THE END THE COLLAR.

SCALE 10:1 UNITS mm	DRAWING NO.	EDC3-*****	PART NO.	BM23FR0.6-**-DP-0.35V(51)
	HRS HIROSE KOREA CO., LTD.		CODE NO.	CL 66**-*****-***