

PART NUMBER	REVISION	DESCRIPTION	FEED TYPE
2151279-1	E	FINE CRIMP HEIGHT ADJUST	MECHANICAL
2151279-2	F	FINE CRIMP HEIGHT ADJUST	PNEUMATIC
5-2151279-1	E	SEAL STRIPPER CRIMPER TERMINATING UNIT	MECHANICAL
5-2151279-2	F	SEAL STRIPPER CRIMPER TERMINATING UNIT	PNEUMATIC
7-2151279-1	E	MECHANICAL AND CRIMP TOOLING KIT	MECHANICAL
7-2151279-2	F	PNEUMATIC AND CRIMP TOOLING KIT	PNEUMATIC
7-2151279-7	A	CRIMP TOOLING KIT	-

ATLANTIC VERSION TERMINATOR INTERFACE ADAPTER



APPLICATOR DATA

CRIMP	SIZE	TYPE
WIRE	2.03 mm [.080]	F
INSUL	2.54 mm [.100]	O

APPLICATOR INSTRUCTIONS 408-35042

TERMINAL DATA: TE TERMINAL TE CRIMP SPECIFICATION

TERMINAL NAME: MICRO TIMER 2 CONTACT

WIRE STRIP LENGTH	INSULATION DIAMETER RANGE
4.00-4.60 mm [.157-.181 IN]	Ø1.40-2.10 mm [.055-.083 IN]

TERMINAL APPLICATION SPECIFICATION (A)114-18081

TERMINALS APPLIED

TE TERMINAL	TE TERMINAL	TE TERMINAL	TE TERMINAL
(A) 962943-1	(A) 962943-5		
(A) 962943-2	(A) 962943-6		
(A) 962943-3	(A) 968052-1		
(A) 962943-4			

TERMINAL DATA: TE TERMINAL TE CRIMP SPECIFICATION

TERMINAL NAME: MICRO TIMER 2 CONTACT

WIRE STRIP LENGTH	INSULATION DIAMETER RANGE
4.00-4.60 mm [.157-.181 IN]	Ø1.40-2.10 mm [.055-.083 IN]

TERMINAL APPLICATION SPECIFICATION (B)114-18082

TERMINALS APPLIED

(B)962948-1	(B)962900-3	(B)962948-2	(B)962900-4
(B)963900-1			
(B)962900-2			

WIRE SIZE	CRIMP HEIGHT mm [INCH]	CRIMP HEIGHT REFERENCE SETTING
1.00mm2	1.20+/-0.05 [.047+/- .002]	5.6
0.75mm2	1.18+/-0.05 [.046+/- .002]	5.8
0.50mm2	1.15+/-0.05 [.045+/- .002]	6.1

WIRE SIZE	CRIMP HEIGHT mm [INCH]	CRIMP HEIGHT REFERENCE SETTING
1.00mm2	1.38+/-0.05 [.054+/- .002]	3.8
0.75mm2	1.29+/-0.05 [.051+/- .002]	4.6
0.50mm2	1.20+/-0.05 [.047+/- .002]	5.6

- 1 RECOMMENDED SPARE PARTS
  - 2 REFER TO SUPPLIED INSTRUCTION SHEET FOR CLEANING, LUBRICATION AND STORAGE OF APPLICATOR.
  - 3 APPLY PART NUMBER 2-23419-6 LOCTITE TO THREADS OF ITEM 242. APPLY PART NUMBER 1-23419-5 LOCTITE TO THREADS OF ITEM 180.
  - 4 CRIMP HEIGHT REFERENCE SETTING WAS THE SETTING USED WHEN THE APPLICATOR WAS QUALIFIED AT THE FACTORY. ADJUSTMENT MAY BE NECESSARY WHEN RUNNING APPLICATOR IN THE FIELD.
  - 5 TERMINAL LUBRICANT IS RECOMMENDED.
6. UNLESS SPECIFIED OTHERWISE TORQUE VALUES SHALL BE USED PER DOCUMENT, 101-35000.

**\*WARNING**  
ON INSTALLATION, SET WIRE DISC TO CRIMP HEIGHT REFERENCE SETTING FOR LARGEST WIRE SIZE. CRIMP HEIGHT REFERENCE SETTINGS GREATER THAN THE VALUE SHOWN MAY CAUSE DAMAGE TO THE CRIMP TOOLING, REFER TO THE INSTRUCTION SHEET FOR PROPER SETUP AND ADJUSTMENTS.

LOC	DIST	REV	DATE	BY	CHKD
A	66	D	23MAY2018	YY	JDG
		E	27AUG2018	TB	TE
		E1	07DEC2018	JAH	GB
		F	15JUN2019	TB	TE

REV	DATE	BY	CHKD	DESCRIPTION	ITEM NO	
-	-	-	1 1 - -	1803515-3	RAM ASSEMBLY, SF ATLANTIC	293
-	-	-	1 1 - -	2-1803583-1	APPLICATOR BASIC ASSEMBLY, SF	292
-	1	-	1 - 1 -	2119641-1	FEED CAM, AIR FEED	248
-	1	1	1 1 1 1	2119082-8	CAM, SNAIL, INSULATION ADJUSTMENT	244
-	1	1	1 1 1 1	2079764-1	WASHER, WAVE SPRING, CREST-TO-CREST	243
3	-	1	1 1 1 1 1 1	2119083-1	RETAINER, INSULATION DIAL	242
-	1	1	1 1 1 1 1 1	7-18023-7	SCR, SKT HD CAP M3 X 4.0	241
-	-	1	- 1 - -	2119580-1	MECHANICAL FEED ASSEMBLY	239
-	1	-	1 - 1 -	2844940-1	AIR FEED MODULE	238
-	-	-	1 1 - -	4-1722335-3	STRIPPER, SIDE FEED	182
-	-	-	1 1 - -	1-5018030-0	NUT, HEX, REG, RoHS, M3.5	181
3	-	-	- 1 1 - -	1-1752354-9	STANDOFF,HOLD-DOWN	180
-	-	-	1 1 - -	993111-1	PIN, SLOTTED SPRING 3.0 X 20.0	177
-	-	-	1 1 - -	5-22280-0	SPRING, COMPRESSION	176
-	-	-	1 1 - -	1752353-3	GUIDE PIN,HOLDDOWN	175
-	-	-	1 1 - -	1901680-2	GUIDE PIN,HOLDDOWN	174
-	REF	REF	REF REF REF REF	994970-2	COUNTER, MAGNETIC	164
5	-	1	1 1 1 1 1 1	2119955-1	ASSY, LUBRICATOR, SIDE FEED	113
-	1	1	1 1 1 1 1 1	2844908-1	SCREW, LOCKING	99
-	1	1	1 1 1 1 1 1	2844907-1	POST, LOCKING	98
-	1	1	1 1 1 1 1 1	455888-5	SPACER, CRIMPER	82
-	1	1	1 1 1 1 1 1	1803607-3	DOCUMENTATION PACKAGE	71
-	1	1	1 1 1 1 1 1	2119791-5	DEPRESSOR, WIRE	70
-	1	1	1 1 1 1 1 1	2119943-1	WASHER, SPACER	69
-	1	1	1 1 1 1 1 1	2119740-1	TAG, IDENTIFICATION	67
-	2	2	2 2 2 2 2 2	2168078-1	SCREW, DRIVE, RH, RoHS, 2 x .188	66
-	1	1	1 1 1 1 1 1	2168083-2	SCR, SKT HD CAP, RoHS, M4 X 8.0	60
-	1	1	1 1 1 1 1 1	5-18022-5	SCR, HEX HD CAP, M4 X 6.0	59
-	1	1	1 1 1 1 1 1	1338685-1	PAWL, FEED	56
-	4	4	4 4 4 4 4 4	2168083-3	SCR, SKT HD CAP, RoHS, M4 X 12.0	54
-	2	2	2 2 2 2 2 2	2168083-3	SCR, SKT HD CAP, RoHS, M4 X 12.0	53
-	1	1	1 1 1 1 1 1	1803382-6	HOLD DOWN, SPRING LOADED	50
-	1	2	1 2 1 2 1 2	18023-9	SCR, SKT HD CAP M4 X 6.0	49
-	-	1	- 1 - -	2119652-1	FEED CAM, PRE FEED	48
-	-	1	- 1 - -	2119653-1	FEED CAM, POST FEED	47
-	1	1	- - 1 1	1803583-9	APPLICATOR BASIC ASSEMBLY, SF	46
-	1	1	- - 1 1	1803515-1	RAM ASSEMBLY, SF ATLANTIC	44
-	1	1	1 1 1 1 1 1	1803602-1	SCR, BHSC, RoHS (M8 X 25)	41
-	1	1	1 1 1 1 1 1	1-1752356-8	SUPPORT, TERMINAL	34
-	2	2	2 2 2 2 2 2	2079383-5	SCR, BHSC, RoHS (M4 X 20)	33
-	2	2	2 2 2 2 2 2	2-2844962-8	SPACER, CYLINDRICAL, STRIP GUIDE	30
-	1	1	1 1 1 1 1 1	2844992-2	ASSEMBLY, STRIP GUIDE	29
-	1	1	1 1 1 1 1 1	1-455888-0	SPACER, CRIMPER	28
-	1	1	1 1 1 1 1 1	1320928-2	STRIP GUIDE	24
-	1	1	- - 1 1	2168083-2	SCR, SKT HD CAP, RoHS, M4 X 8.0	21
-	2	2	1 1 2 2	1-18028-2	WASHER, FLAT, REG M4	20
-	1	1	- - 1 1	2119533-1	STRIPPER, SIDE FEED	19
1	-	1	1 1 1 1 1 1	2119806-1	INSERT, SHEAR	13
-	1	1	1 1 1 1 1 1	3-22280-3	SPRING, COMPRESSION	12
-	1	1	1 1 1 1 1 1	1-356885-4	STOP, SHEAR	11
1	-	1	1 1 1 1 1 1	2119805-1	SHEAR HOLDER, FRONT	10
1	-	1	1 1 1 1 1 1	454276-5	FLOATING SHEAR, FRONT	9
1	1	2	2 1 1 1 1 1	1-1333204-5	ANVIL, COMBINATION	8
-	1	1	1 1 1 1 1 1	240641-9	SPACER	7
-	-	-	- - - -	-	-	6
-	1	1	1 1 1 1 1 1	2119757-4	DEPRESSOR, SHEAR	5
-	1	1	1 1 1 1 1 1	238011-4	BLOCK, CRIMPER SPACER	4
1	1	2	2 1 1 1 1 1	4-2119784-0	CRIMPER, INSULATION O PREMIUM	3
-	1	1	1 1 1 1 1 1	455888-9	SPACER, CRIMPER	2
1	1	2	2 1 1 1 1 1	1-456405-6	CRIMPER, WIRE PREMIUM	1

ATLANTIC VERSION  
Shown on sheets 1 of 4 & 2 of 4  
(Pacific version shown on sheets 3 of 4 & 4 of 4)

DIMENSIONS: mm		TOLERANCES UNLESS OTHERWISE SPECIFIED:		OWN: H. HUANG 09DEC2011	TE Connectivity
0 PLC ±		1 PLC ±		CHK: S.XI 09DEC2011	Harrisburg, PA 17105-3608
2 PLC ±		3 PLC ±		APVD: J. CRUZ 09DEC2011	
4 PLC ±		ANGLES ±		NAME: OCEAN SIDE FEED APPLICATOR	
FINISH		MATERIAL		SIZE: A1	CAGE CODE: 00779
DRAWING NO: 2151279		RESTRICTED TO:		SCALE: 1:2	SHEET 1 OF 4
Customer Accessible Production Drawing		Customer Accessible Production Drawing		REV F	

LOC	DIST	REVISIONS					
		P	LTN	DESCRIPTION	DATE	OWN	APVD
A	66	-	-	SEE SHEET 1	-	-	-

# FEED TYPE MECHANICAL

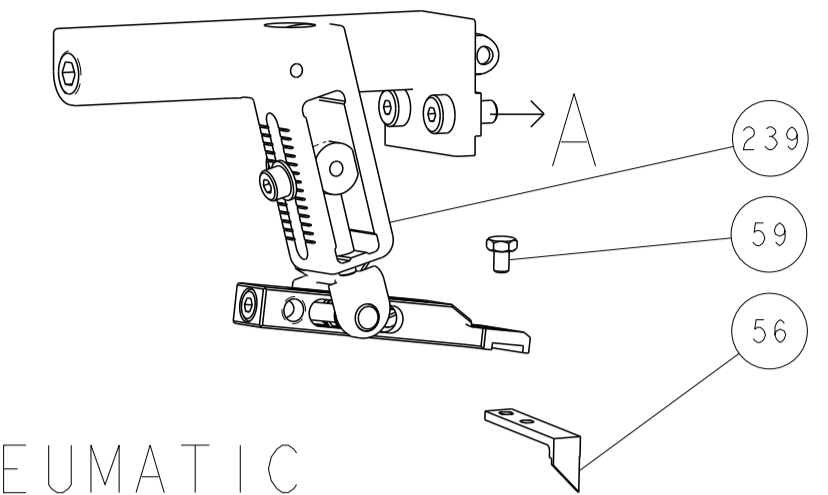

## PNEUMATIC

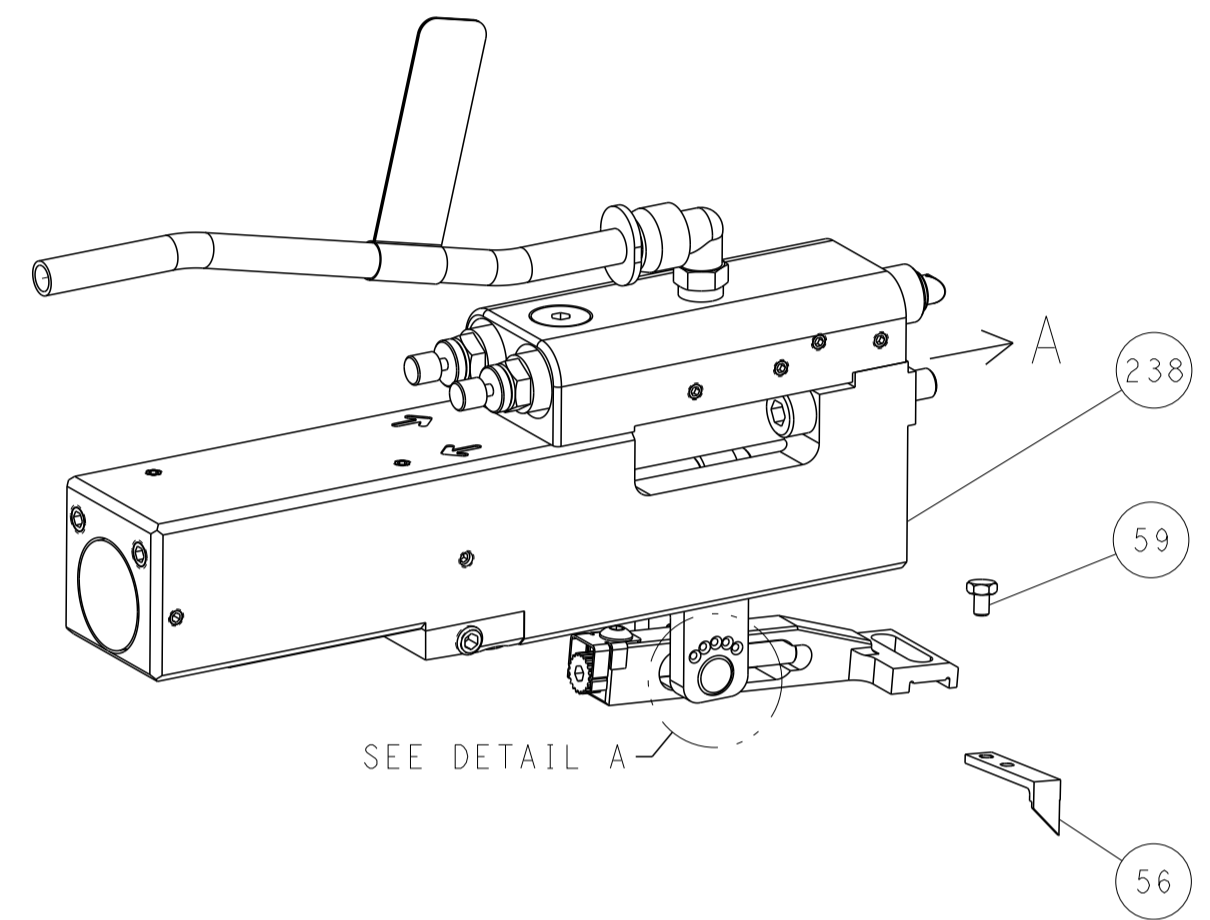

## FEED SPRING SETTING POSITION (SHOWN FROM REAR SIDE)

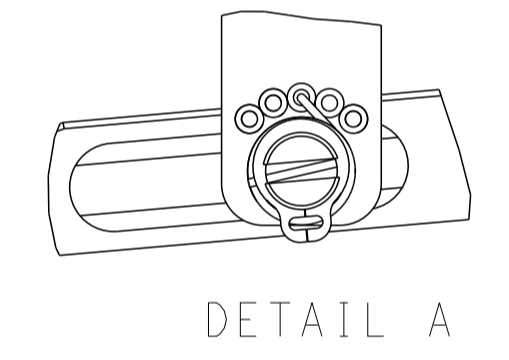

# CAM POSITIONS

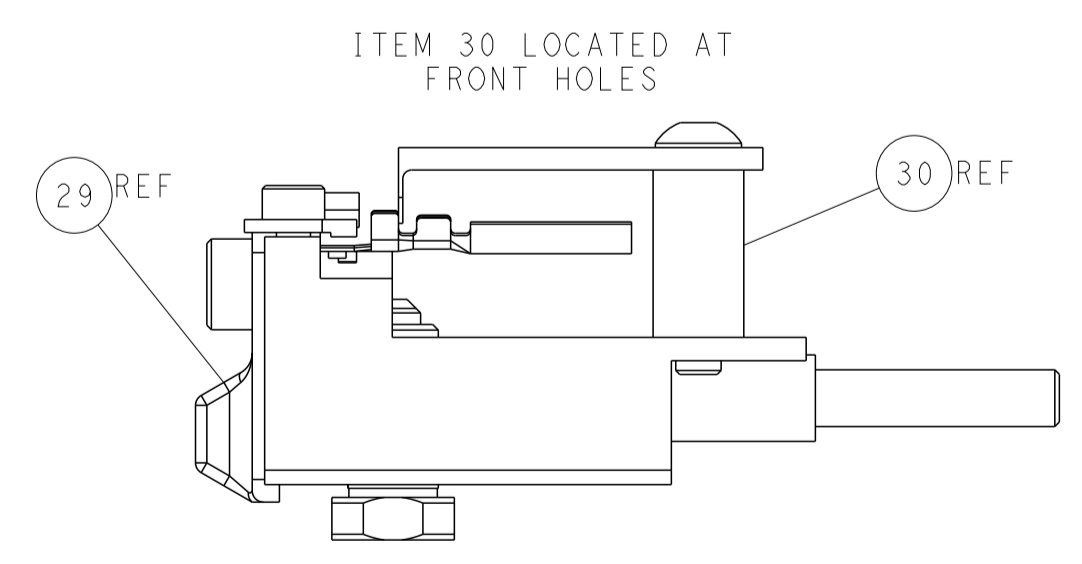
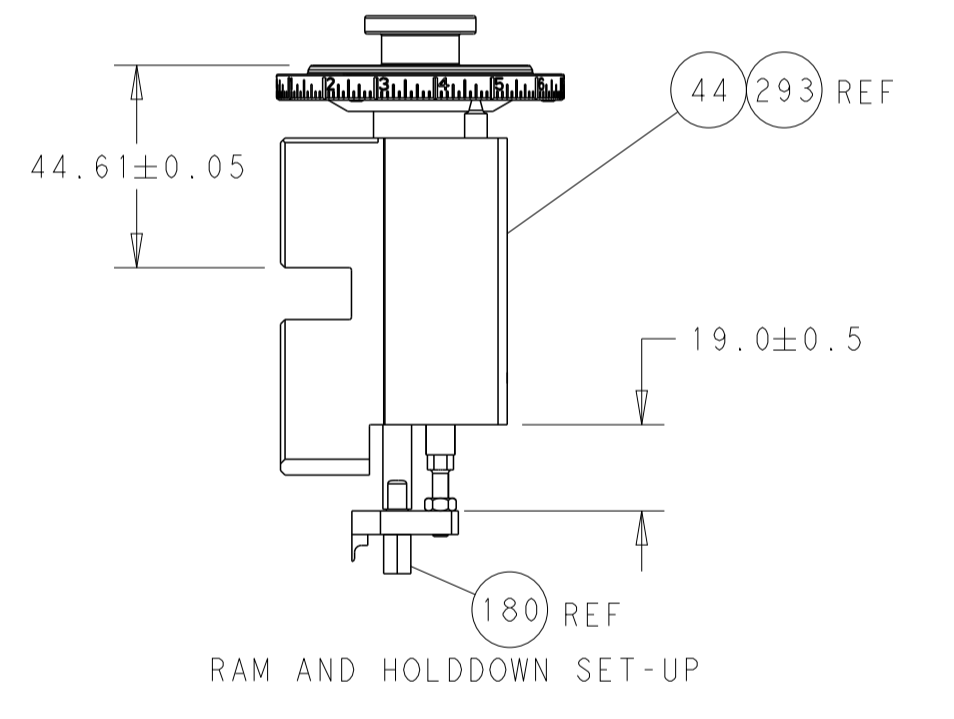
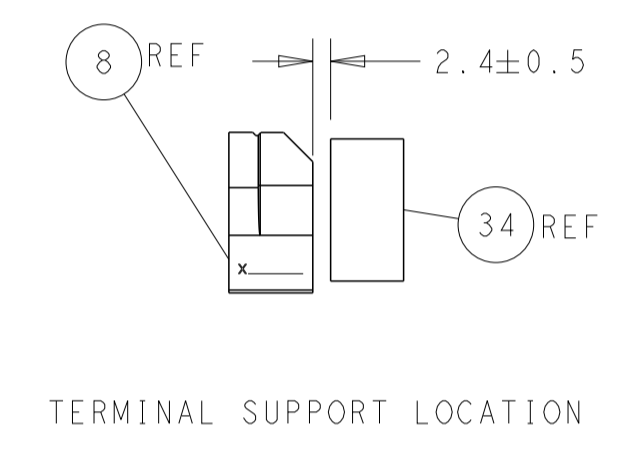
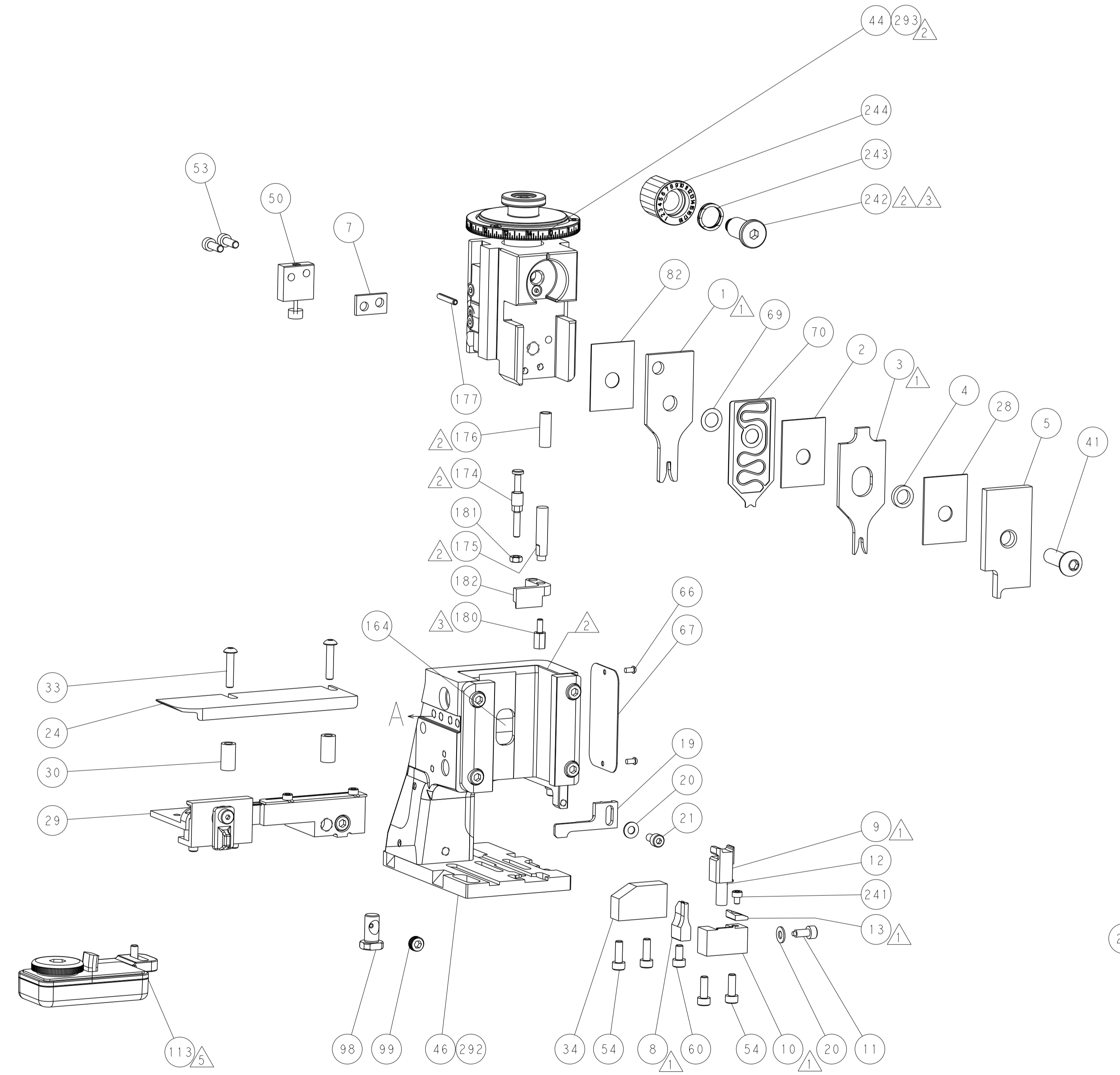
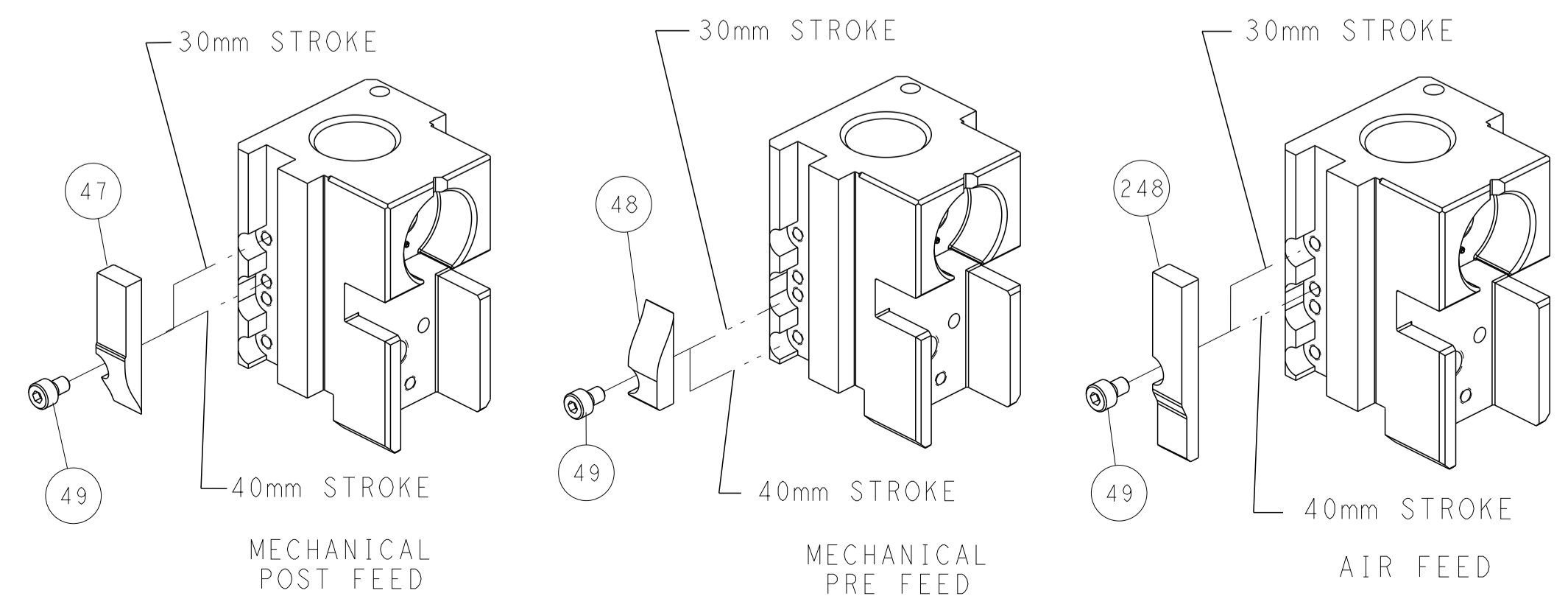

FEED TRACK POSITION GUIDE BY INSULATION BARREL

**ATLANTIC VERSION**  
 Shown on sheets 1 of 4 & 2 of 4  
 (Pacific version shown on sheets 3 of 4 & 4 of 4)

<small>THIS DRAWING IS UNPUBLISHED. RELEASED FOR PUBLICATION BY TYCO ELECTRONICS CORPORATION. ALL RIGHTS RESERVED.</small>		DWN: R. HUANG 09DEC2011 CHK: S. XI 09DEC2011 APVD: J. CRUZ 09DEC2011	NAME: OCEAN SIDE FEED APPLICATOR SIZE: A1 CAGE CODE: 00779 DRAWING NO: 2151279	TE Connectivity Harrisburg, PA 17105-3608
DIMENSIONS: mm TOLERANCES UNLESS OTHERWISE SPECIFIED: 0 PLC ± 1 PLC ± 2 PLC ± 3 PLC ± 4 PLC ± ANGLES FINISH	TOLERANCES UNLESS OTHERWISE SPECIFIED: ± ± ± ± ±	PRODUCT SPEC APPLICATION SPEC WEIGHT SCALE: 1:2	SHEET 2 OF 4 REV F	RESTRICTED TO

PART NUMBER	REVISION	DESCRIPTION	FEED TYPE
2-2151279-1	E	FINE CRIMP HEIGHT ADJUST	MECHANICAL
2-2151279-2	F	FINE CRIMP HEIGHT ADJUST	PNEUMATIC
7-2151279-7	A	CRIMP TOOLING KIT	-

PACIFIC VERSION TERMINATOR INTERFACE ADAPTER

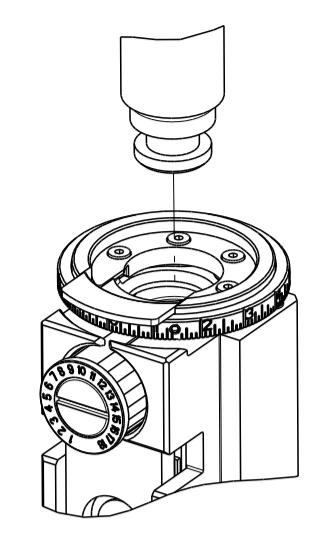

APPLICATOR DATA		
CRIMP	SIZE	TYPE
WIRE	2.03 mm [.080]	F
INSUL	2.54 mm [.100]	O
APPLICATOR INSTRUCTIONS 408-35042		

TERMINAL DATA: TE TERMINAL		TE CRIMP SPECIFICATION	
TERMINAL NAME: MICRO TIMER 2 CONTACT			
WIRE STRIP LENGTH		INSULATION DIAMETER RANGE	
4.00-4.60 mm [1.57-.181 IN]		Ø1.40-2.10 mm [0.055-.083 IN]	
TERMINAL APPLICATION SPECIFICATION	(A)114-18081	-	-
TERMINALS APPLIED			
TE TERMINAL	TE TERMINAL	TE TERMINAL	TE TERMINAL
(A) 962943-1	(A) 962943-5		
(A) 962943-2	(A) 962943-6		
(A) 962943-3	(A) 968052-1		
(A) 962943-4			

TERMINAL DATA: TE TERMINAL		TE CRIMP SPECIFICATION	
TERMINAL NAME: MICRO TIMER 2 CONTACT			
WIRE STRIP LENGTH		INSULATION DIAMETER RANGE	
4.00-4.60 mm [1.57-.181 IN]		Ø1.40-2.10 mm [0.055-.083 IN]	
TERMINAL APPLICATION SPECIFICATION	(B)114-18082	-	-
TERMINALS APPLIED			
(B)962948-1	(B)962900-3		
(B)962948-2	(B)962900-4		
(B)963900-1			
(B)962900-2			

WIRE SIZE	CRIMP HEIGHT mm [INCH]	CRIMP HEIGHT REFERENCE SETTING
1.00mm2	1.20+/-0.05 [0.047+/-0.002]	5.6
0.75mm2	1.18+/-0.05 [0.046+/-0.002]	5.8
0.50mm2	1.15+/-0.05 [0.045+/-0.002]	6.1

WIRE SIZE	CRIMP HEIGHT mm [INCH]	CRIMP HEIGHT REFERENCE SETTING
1.00mm2	1.38+/-0.05 [0.054+/-0.002]	3.8
0.75mm2	1.29+/-0.05 [0.051+/-0.002]	4.6
0.50mm2	1.20+/-0.05 [0.047+/-0.002]	5.6



- RECOMMENDED SPARE PARTS
  - REFER TO SUPPLIED INSTRUCTION SHEET FOR CLEANING, LUBRICATION AND STORAGE OF APPLICATOR.
  - APPLY PART NUMBER 2-23419-6 LOCTITE TO THREADS OF ITEM 242.
  - CRIMP HEIGHT REFERENCE SETTING WAS THE SETTING USED WHEN THE APPLICATOR WAS QUALIFIED AT THE FACTORY. ADJUSTMENT MAY BE NECESSARY WHEN RUNNING APPLICATOR IN THE FIELD.
  - TERMINAL LUBRICANT IS RECOMMENDED.
6. UNLESS SPECIFIED OTHERWISE TORQUE VALUES SHALL BE USED PER DOCUMENT, 101-35000.

**\*WARNING**  
ON INSTALLATION, SET WIRE DISC TO CRIMP HEIGHT REFERENCE SETTING FOR LARGEST WIRE SIZE. CRIMP HEIGHT REFERENCE SETTINGS GREATER THAN THE VALUE SHOWN MAY CAUSE DAMAGE TO THE CRIMP TOOLING, REFER TO THE INSTRUCTION SHEET FOR PROPER SETUP AND ADJUSTMENTS.

LOC	DIST	REV	DATE	BY	APPV
A	66				

REVISIONS					
REV	DATE	BY	DESCRIPTION	DATE	APPV
-	-	-	SEE SHEET 1	-	-
-	1	1	2119082-8	CAM, SNAIL, INSULATION ADJUSTMENT	244
-	1	1	2079764-1	WASHER, WAVE SPRING, CREST-TO-CREST	243
	-	1	2119083-1	RETAINER, INSULATION DIAL	242
-	1	1	7-18023-7	SCR, SKT HD CAP M3 X 4.0	241
-	-	1	2119580-1	MECHANICAL FEED ASSEMBLY	239
-	1	-	2844940-1	AIR FEED MODULE	238
-	REF	REF	994970-2	COUNTER, MAGNETIC	164
-	1	-	2119641-2	FEED CAM, AIR FEED	151
-	1	1	2168083-8	SCR, SKT HD CAP, RoHS, M4 X 16	144
-	4	4	2168083-9	SCR, SKT HD CAP, RoHS, M4 X 20	143
-	-	1	2119653-2	FEED CAM, POST FEED	142
-	1	1	1-1803583-0	APPLICATOR BASIC ASSEMBLY, SF	141
-	1	1	1803516-1	RAM ASSEMBLY, SF PACIFIC	140
	-	1	2119955-1	ASSY, LUBRICATOR, SIDE FEED	113
-	1	1	2844908-1	SCREW, LOCKING	99
-	1	1	2844907-1	POST, LOCKING	98
-	1	1	455888-5	SPACER, CRIMPER	82
-	1	1	1803607-3	DOCUMENTATION PACKAGE	71
-	1	1	2119791-5	DEPRESSOR, WIRE	70
-	1	1	2119943-1	WASHER, SPACER	69
-	1	1	2119740-1	TAG, IDENTIFICATION	67
-	2	2	2168078-1	SCREW, DRIVE, RH, RoHS, 2 x .188	66
-	1	1	5-18022-5	SCR, HEX HD CAP, M4 X 6.0	59
-	1	1	1338685-1	PAWL, FEED	56
-	2	2	2168083-3	SCR, SKT HD CAP, RoHS, M4 X 12.0	53
-	1	1	1803382-6	HOLD DOWN, SPRING LOADED	50
-	1	2	18023-9	SCR, SKT HD CAP M4 X 6.0	49
-	-	1	2119652-1	FEED CAM, PRE FEED	48
-	1	1	1803602-1	SCR, BHSC, RoHS (M8 X 25)	41
-	1	1	1-1752356-8	SUPPORT, TERMINAL	34
-	2	2	2079383-5	SCR, BHSC, RoHS (M4 X 20)	33
-	2	2	2-2844962-8	SPACER, CYLINDRICAL, STRIP GUIDE	30
-	1	1	2844992-2	ASSEMBLY, STRIP GUIDE	29
-	1	1	1-455888-0	SPACER, CRIMPER	28
-	1	1	1320928-2	STRIP GUIDE	24
-	1	1	2168083-2	SCR, SKT HD CAP, RoHS, M4 X 8.0	21
-	2	2	1-18028-2	WASHER, FLAT, REG M4	20
-	1	1	2119533-1	STRIPPER, SIDE FEED	19
	-	1	2119806-1	INSERT, SHEAR	13
-	1	1	3-22280-3	SPRING, COMPRESSION	12
-	1	1	1-356885-4	STOP, SHEAR	11
	-	1	2119805-1	SHEAR HOLDER, FRONT	10
	-	1	454276-5	FLOATING SHEAR, FRONT	9
	1	1	1-1333204-5	ANVIL, COMBINATION	8
-	1	1	240641-9	SPACER	7
-	-	-	-	-	6
-	1	1	2119757-4	DEPRESSOR, SHEAR	5
-	1	1	238011-4	BLOCK, CRIMPER SPACER	4
	1	1	4-2119784-0	CRIMPER, INSULATION O PREMIUM	3
-	1	1	455888-9	SPACER, CRIMPER	2
	1	1	1-456405-6	CRIMPER, WIRE PREMIUM	1

PACIFIC VERSION  
Shown on sheets 3 of 4 & 4 of 4  
(Atlantic version shown on sheets 1 of 4 & 2 of 4)

DIMENSIONS: mm		TOLERANCES UNLESS OTHERWISE SPECIFIED:		DWG: H. HUANG 09DEC2011 CHK: S. XI 09DEC2011 APPV: J. CRUZ 09DEC2011	
0 PLC	±	0.15	±	NAME: OCEAN SIDE FEED APPLICATOR	
1 PLC	±	0.25	±	SIZE: A1	
2 PLC	±	0.38	±	CAGE CODE: 00779	
3 PLC	±	0.51	±	DRAWING NO: C=2151279	
4 PLC	±	0.76	±	SCALE: 1:2	
ANGLES	±	0.15	±	SHEET: 3 OF 4	
FINISH	±	0.15	±	REV: F	

Customer Accessible Production Drawing

LOC	DIST	REVISIONS					
A	66	P	LTN	DESCRIPTION	DATE	OWN	APVD
-	-	-	-	SEE SHEET 1	-	-	-

# FEED TYPE MECHANICAL

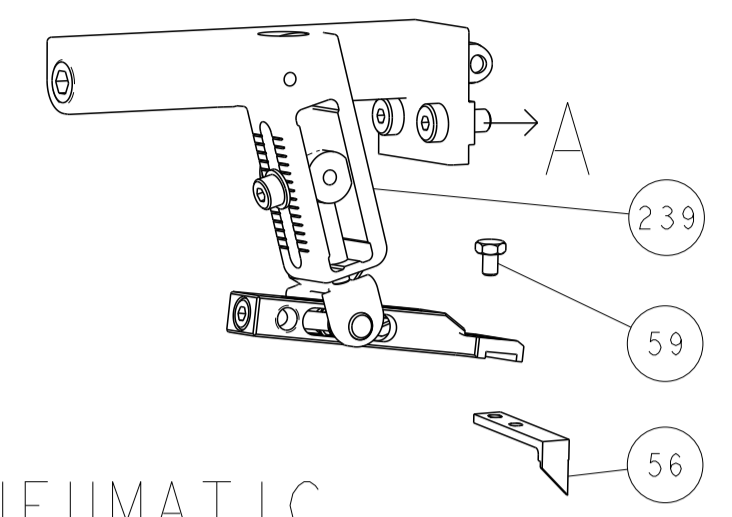

## PNEUMATIC

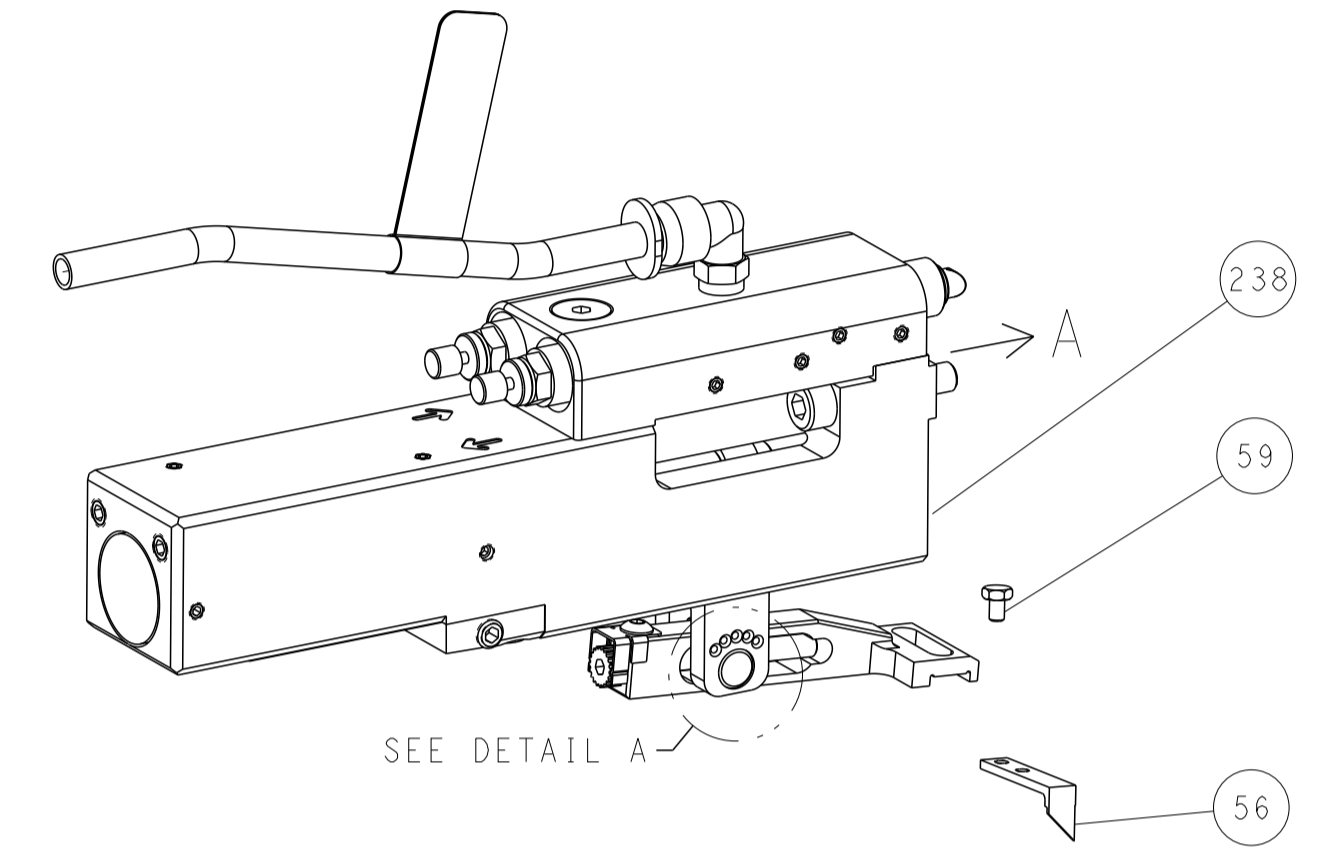

### FEED SPRING SETTING POSITION (SHOWN FROM REAR SIDE)

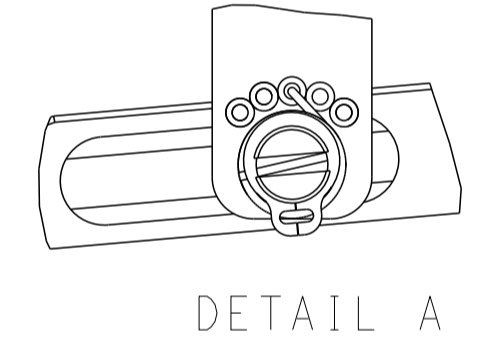

## CAM POSITIONS

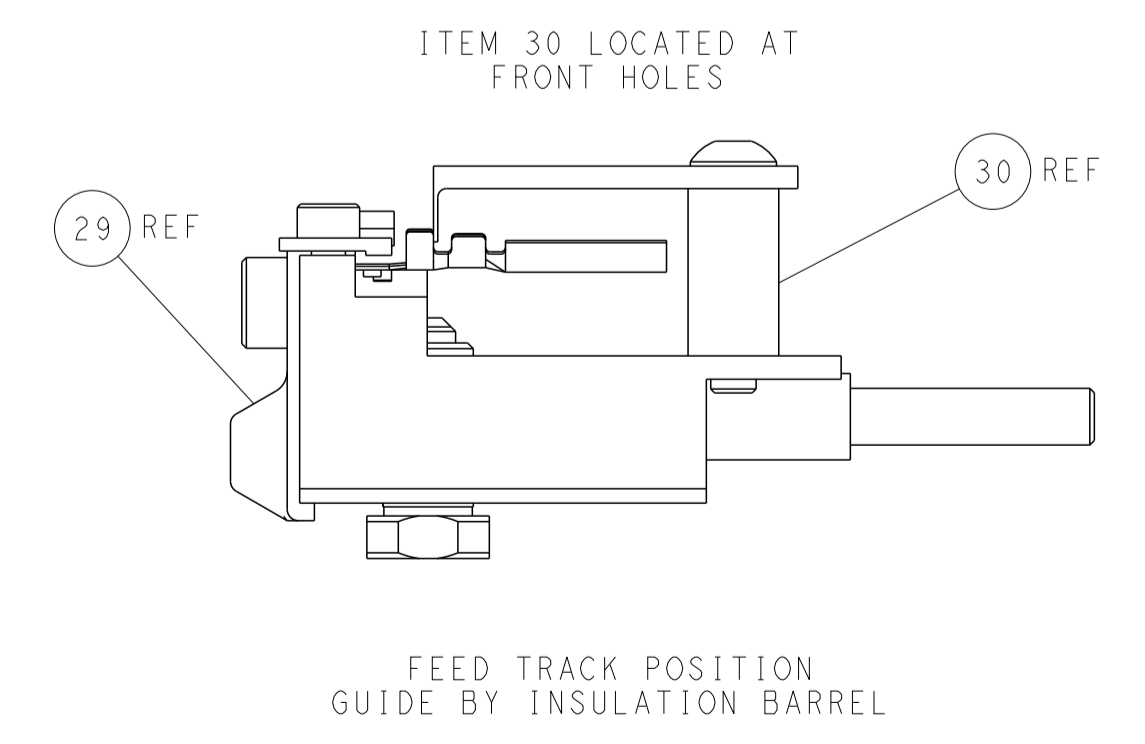
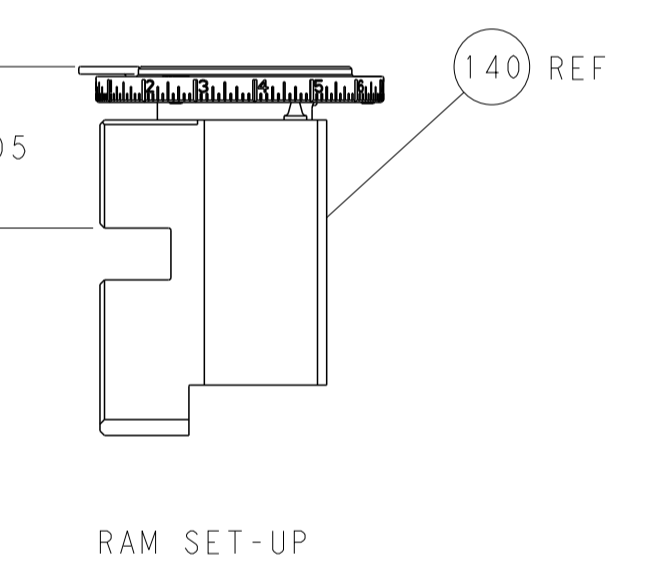
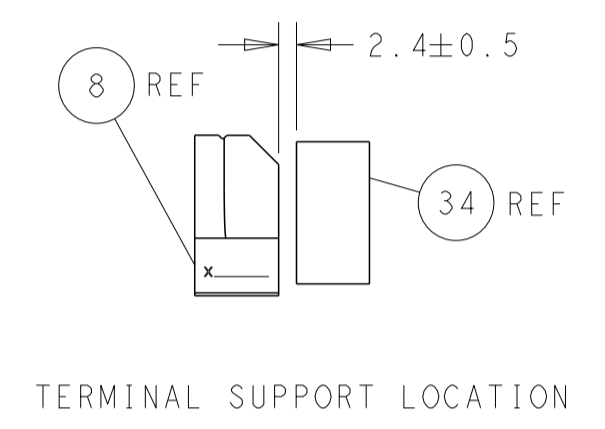
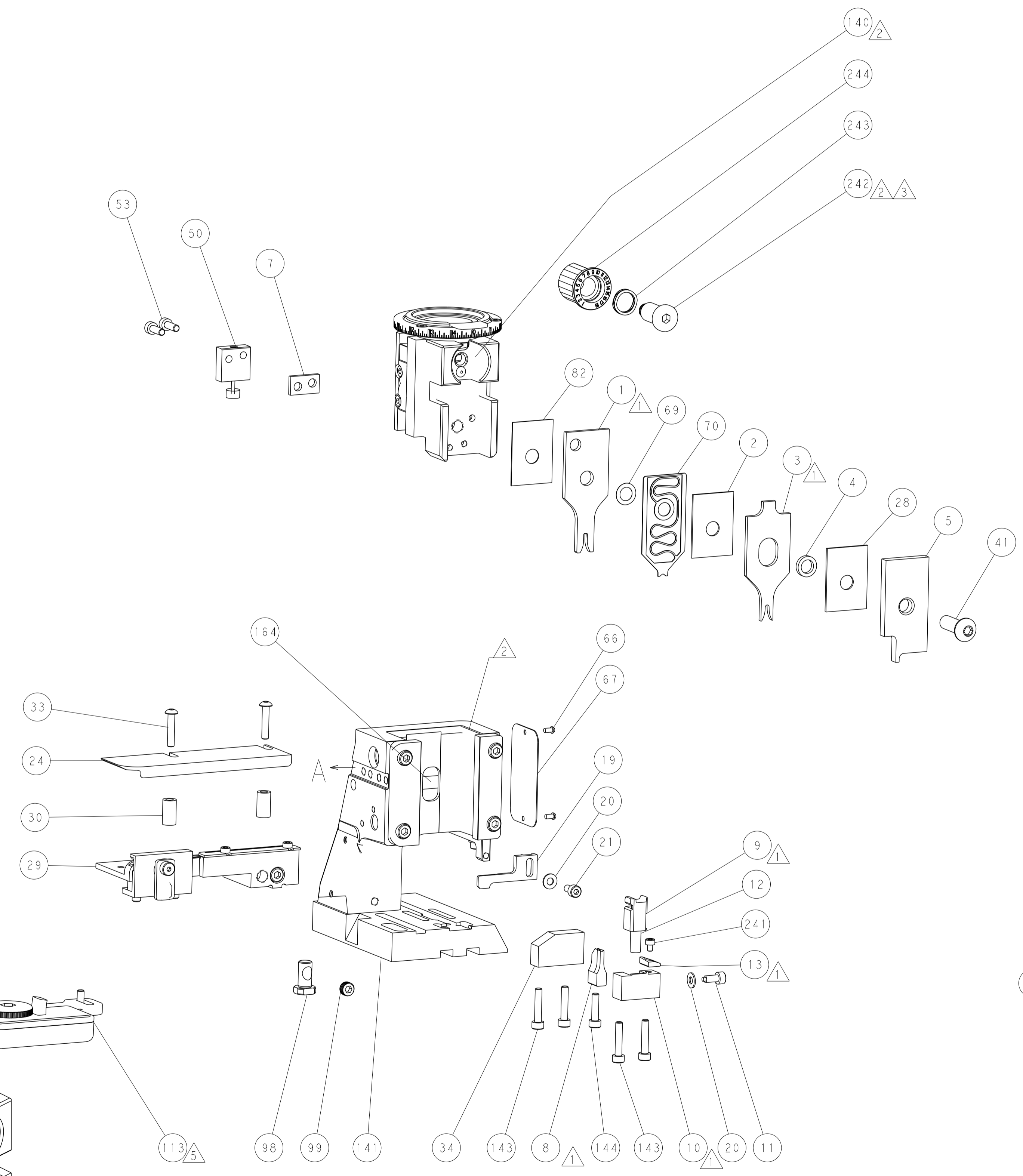
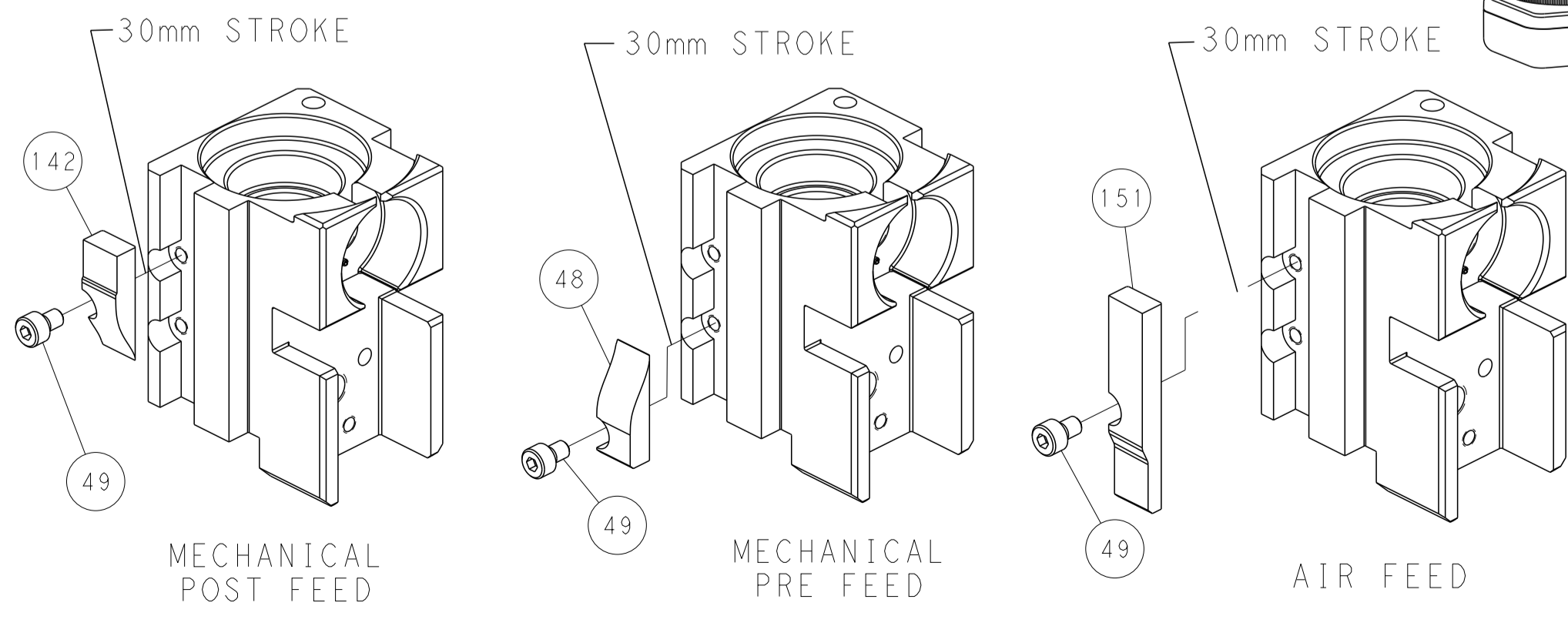

**PACIFIC VERSION**  
 Shown on sheets 3 of 4 & 4 of 4  
 (Atlantic version shown on sheets 1 of 4 & 2 of 4)

<small>THIS DRAWING IS UNPUBLISHED. RELEASED FOR PUBLICATION. ALL RIGHTS RESERVED. THIS DRAWING IS THE PROPERTY OF TYCO ELECTRONICS CORPORATION. IT IS TO BE USED ONLY FOR THE PURPOSES AND IN THE MANNER SPECIFIED BY THE DRAWING. IT IS NOT TO BE REPRODUCED OR TRANSMITTED IN ANY FORM OR BY ANY MEANS, ELECTRONIC OR MECHANICAL, INCLUDING PHOTOCOPYING, RECORDING, OR BY ANY INFORMATION STORAGE AND RETRIEVAL SYSTEM, WITHOUT THE WRITTEN PERMISSION OF TYCO ELECTRONICS CORPORATION.</small>		DWN: R. HUANG 09DEC2011 CHK: S. XI 09DEC2011 APVD: J. CRUZ 09DEC2011	NAME: OCEAN SIDE FEED APPLICATOR SIZE: A1 CAGE CODE: 00779 DRAWING NO: 2151279	TE Connectivity Harrisburg, PA 17105-3608
DIMENSIONS: mm TOLERANCES UNLESS OTHERWISE SPECIFIED: 0 PLC ± 1 PLC ± 2 PLC ± 3 PLC ± 4 PLC ± ANGLES ± FINISH	TOLERANCES UNLESS OTHERWISE SPECIFIED: 0 PLC ± 1 PLC ± 2 PLC ± 3 PLC ± 4 PLC ± ANGLES ± FINISH	PRODUCT SPEC: APPLICATION SPEC: WEIGHT:	RESTRICTED TO: SCALE: 1:2 SHEET 4 OF 4 REV F	CUSTOMER ACCESSIBLE PRODUCTION DRAWING