

# NCN8024RGEVB

## NCN8024R SOIC-28 Evaluation Board User's Manual



ON Semiconductor®

<http://onsemi.com>

### EVAL BOARD USER'S MANUAL

#### Introduction

This document gives a detailed description of the NCN8024R Evaluation Boards (SOIC-28 version) with the Bill Of Material (BOM), board schematic and layout. The appropriate lab test setup is also provided. The NCN8024R Evaluation Boards have been designed to help for a quick evaluation of the NCN8024R Smart card interface device.

This document has to be used with the NCN8024R datasheet. The datasheet contains full technical details regarding the NCN8024R specifications and operation. The board (FR4 material) is implemented in two metal layers. The top and Bottom layers have thicknesses of 35  $\mu\text{m}$ . The PCB thickness is 1.6 mm with dimensions of 100 mm by 74 mm (see Figure 1).

These evaluation boards can be used to evaluate the device performance. This evaluation board is the same than the NCN8024 device. C1 and C2 not populated constitute the only difference with the NCN8024 Evaluation Board.

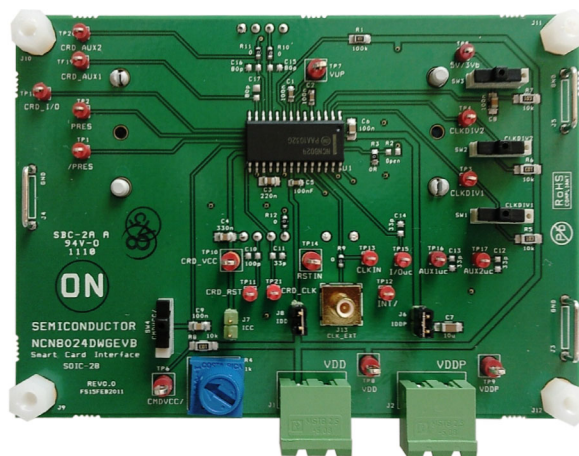

Figure 1. Evaluation Board – SOIC-28

Table 1. EQUIPMENT

Description	Main Features	Example of Equipment (Note 1)	Qty
Regulated Power Supply	200 mA DC Current Capability	Tektronix PS2520G	2
Multimeter		Keitley 2000 or 2001	2
Sourcemeater		Keitley 2400	1
Oscilloscope	500 MHz Bandwidth, Four Channel Scope, Min 1 Mbit Memory per Channel (Note 2)	Tecktronix TDS744, 754 or 784/TDS5054 Series or Lecroy WR5060 TDS5104B, 1 GHz, 5GS/s	1
Voltage Probe	4 Probes 500 MHz Bandwidth	Tektronix or Lecroy	4
Waveform Generator	Pattern Genarator	Agilent 81104A 80 MHz or HP8110A 150 MHz 2 Outputs	1
SMB Cable		External Clock Input	1

1. Equipment used in the context of this Application Note Manual.
2. Greater Scope memory per channel offers better resolution.

# NCN8024RGEVB

## Test Procedure

See Figure 2.

## Initial Setups (Figure 2)

The initial setups given here are recommended before starting measurements on the board.

- Set the CMDVCC/in the OFF Position (High)
- Set CLKDIV1 and CLKDIV2 into Low Position (Lowest Frequency Fclkin)
- Set 5V/3Vbar into a 5V Position
- As a Precaution, Turn the 1 kΩ Potentiometer to Obtain a Resistor Output Value of 1 kΩ, and then Connect the Jumper

## DC Power Supplies

Two power supplies are used to bias the demo board.  $V_{DDP}$  is the input voltage of the DC-DC converter.  $V_{DD}$  is the “digital” power supply which biases the input stages of the NCN8024 device (control and signal inputs).

$V_{DD}$  and  $V_{DDP}$  must be connected to the board for a correct operation.

- Connect the  $V_{DD}$  Power Supply Using the 2 Pin Male Connector J1
- Connect the  $V_{DDP}$  Power Supply Using the 2 Pin Male Connector J2
- Power up  $V_{DDP}$  in the Range 4.85 V–5.5 V
- Power up  $V_{DD}$  in the Range 2.7 V–5.5 V

## Clock Frequency

CLKDIV1 and CLKDIV2 select the frequency divider according to the Table 2.

**Table 2. CLOCK FREQUENCY**

CLKDIV1	CLKDIV2	Divider
1	0	DIV 1/1
1	1	DIV 1/2
0	1	DIV 1/4
0	0	DIV 1/8

## Card Presence

The socket we use is a normally open, so CDR-PRES/ has been chosen; nevertheless the CRD\_PRES and CRD\_PRES/ test points can also be used for signaling the presence of a card and starting up the circuit.

## Start the Measurement

To start the measurements, set the board as it follows:

- Set CLKDIV1 and CLKDIV2 to Select the Correct Frequency
- Set 5V/3Vbar to Select the Correct Output Voltage
- Jumpers:
  - ♦ 1 kΩ Potentiometer Jumper: Not Connected to Start Measurement
- Finally, Toggle/CMDVCC from High to Low to Start the Device (Activation Sequence Run)

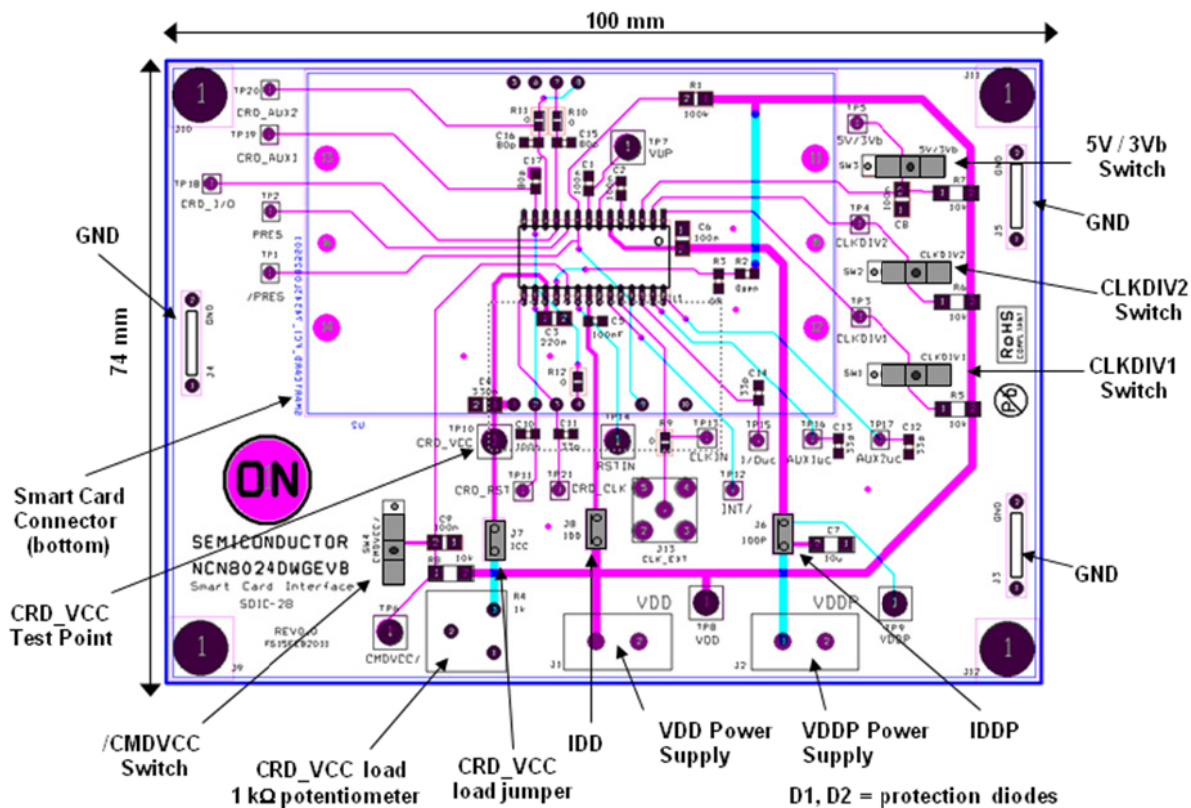

Figure 2. SOIC-28 Board Description

# NCN8024RGEVB

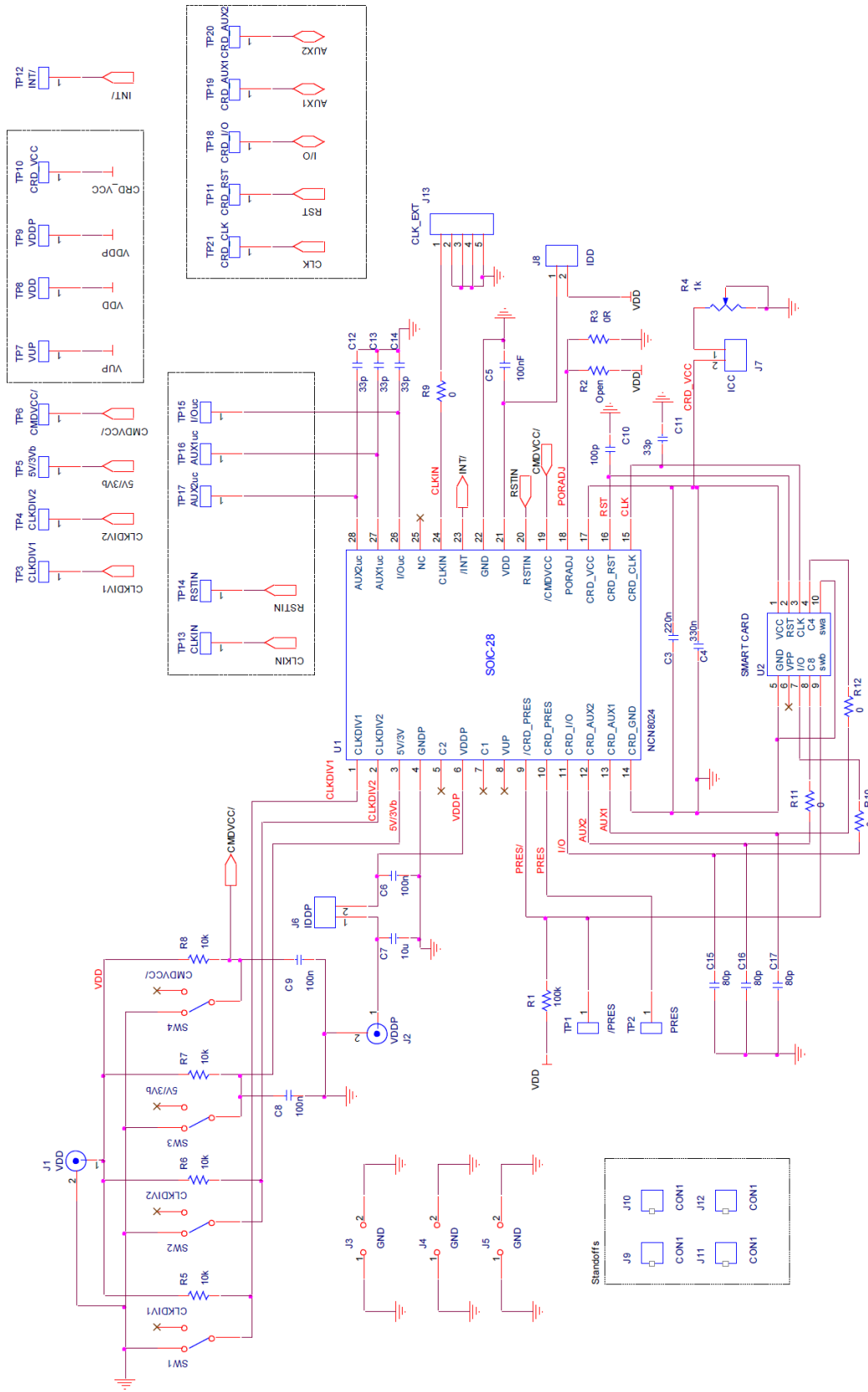

Figure 3. Schematic

# NCN8024RGEVB

**Table 3. BILL OF MATERIAL (BOM)**

Designator	Qty	Description	Value	Footprint	Manufacturer	Part Number
C1, C2	2	CAP CER .1 $\mu$ F 16 V 10% X7R 0603	100 nF	SM/C_0603H	Do Not Populate	Do Not Populate
C3	1	CAP CER .22 $\mu$ F 16 V X7R 10% 0805	220 nF	SM/C_0805H	TDK	C2012X7R1C224K
C4	1	CAP CER .33 $\mu$ F 16 V X7R 10% 0805	330 nF	SM/C_0805H	TDK	C2012X7R1C334K/1.25
C5, C6	2	CAP CER .1 $\mu$ F 25 V 10% X7R 0805	100 nF	SM/C_0805H	Murata	GRM21BR71E104KA01L
C7	1	CAP CER 10 $\mu$ F 6.3 V X5R 10% 1206	10 $\mu$ F	SM/C_1206H	TDK	C3216X5R0J106K/1.60
C8, C9	2	CAP CER .1 $\mu$ F 25 V 10% X7R 0805	100 nF	SM/C_0805H	Murata	GRM21BR71E104KA01L
C10	1	Do Not Populate	-	SM/C_0603H	Do Not Populate	Do Not Populate
C11, C12, C13, C14	4	Do Not Populate	-	SM/C_0603H	Do Not Populate	Do Not Populate
C15, C16, C17	3	Do Not Populate	-	SM/C_0603H	Do Not Populate	Do Not Populate
R1	1	RES 100 k $\Omega$ 1/4 W 5% 0805 SMD	100 k $\Omega$	SM/C_0805H	Rohm Semiconductor	ESR10EZPJ104
R2	1	Do Not Populate	-	SM/C_0603H	Do Not Populate	Do Not Populate
R3, R9, R10, R11, R12	5	RES 0.0 $\Omega$ 1/10 W 0603 SMD	0	SM/C_0603H	Stackpole Electronics Inc	RMCF0603ZTOR00
R4	1	Single Turn Cermet Trimmer 1 k $\Omega$ , 0.5 W, 10%, 63M100R	1 k $\Omega$	CERMET-72PT	Bourns	3386F-1-102TLF
R5, R6, R7, R8	4	RES 10 k $\Omega$ 1/4 W 5% 1206 SMD	10 k $\Omega$	SM/C_1206H	Rohm Semiconductor	MCR18EZPJ103
SW1, SW2, SW3, SW4	4	PCB Slide Switches	-	INTER3-2,54	EAO	09.03290.01
TP1-TP5, TP11-TP13, TP15-TP21	15	CLKDIV1/2, 5 V/3 Vb, INT/, I/OUC, AUX1UC, AUX2UC, CLKIN, CRD_AUX1, _AUX2, _I/O, _CLK, _RST, _PRES, PRES, Clip Test Point Hole Diameter 1.0 mm	-	TP_1	Keystone	5000
TP6, TP7, TP8, TP9, TP10, TP14	6	/CMDVCC, VUP, VDD, VDDP, CRD_VCC, RSTIN, Clip Test Point Hole Diameter 1.6 mm	-	TP_1.6MMHOLE_KEYS TONE_5010	Keystone	5010
J1, J2	2	VDD, VDDP, 2 Pins, Male Connector, 5.08 mm Step	-	MSTBA2-5.08MM	Phoenix Contact	MSTBA2.52G5.08
J3, J4, J5	3	Ground: Strap, Brass, Diameter 1.0 mm, Pitch 10.16 mm, Height 9.9 mm	-	GND_STRP	HARWIN	D3082-46
J6, J7, J8	3	IDD, IDDP, ICC, Breakable Single Row, Header (2 Pins)	-	CON2-2.54	TYCO Amp	5-826629-0
J9, J10, J11, J12	4	Standoff Nut	-	Standoff Hole	Keystone	1903C
J9, J10, J11, J12	4	Standoff Screw	-	Standoff Hole	Keystone	4814K-ND
J13	1	SMB Connector	-	SMB/V	Amphenol Connex	142138
U1	1	NCN8024R Smart Card Interface	-	SOIC-28	ON Semiconductor	NCN8024RDWR2G
U2	1	Smart Card Socket	-	SmartCard_ FCI_74343L0825S01	FCI	7434L0825S01LF

ON Semiconductor and the ON Semiconductor logo are trademarks of Semiconductor Components Industries, LLC dba ON Semiconductor or its subsidiaries in the United States and/or other countries. ON Semiconductor owns the rights to a number of patents, trademarks, copyrights, trade secrets, and other intellectual property. A listing of ON Semiconductor's product/patent coverage may be accessed at [www.onsemi.com/site/pdf/Patent-Marking.pdf](http://www.onsemi.com/site/pdf/Patent-Marking.pdf). ON Semiconductor is an Equal Opportunity/Affirmative Action Employer. This literature is subject to all applicable copyright laws and is not for resale in any manner.

The evaluation board/kit (research and development board/kit) (hereinafter the "board") is not a finished product and is as such not available for sale to consumers. The board is only intended for research, development, demonstration and evaluation purposes and should as such only be used in laboratory/development areas by persons with an engineering/technical training and familiar with the risks associated with handling electrical/mechanical components, systems and subsystems. This person assumes full responsibility/liability for proper and safe handling. Any other use, resale or redistribution for any other purpose is strictly prohibited.

The board is delivered "AS IS" and without warranty of any kind including, but not limited to, that the board is production-worthy, that the functions contained in the board will meet your requirements, or that the operation of the board will be uninterrupted or error free. ON Semiconductor expressly disclaims all warranties, express, implied or otherwise, including without limitation, warranties of fitness for a particular purpose and non-infringement of intellectual property rights.

ON Semiconductor reserves the right to make changes without further notice to any board.

You are responsible for determining whether the board will be suitable for your intended use or application or will achieve your intended results. Prior to using or distributing any systems that have been evaluated, designed or tested using the board, you agree to test and validate your design to confirm the functionality for your application. Any technical, applications or design information or advice, quality characterization, reliability data or other services provided by ON Semiconductor shall not constitute any representation or warranty by ON Semiconductor, and no additional obligations or liabilities shall arise from ON Semiconductor having provided such information or services.

The boards are not designed, intended, or authorized for use in life support systems, or any FDA Class 3 medical devices or medical devices with a similar or equivalent classification in a foreign jurisdiction, or any devices intended for implantation in the human body. Should you purchase or use the board for any such unintended or unauthorized application, you shall indemnify and hold ON Semiconductor and its officers, employees, subsidiaries, affiliates, and distributors harmless against all claims, costs, damages, and expenses, and reasonable attorney fees arising out of, directly or indirectly, any claim of personal injury or death associated with such unintended or unauthorized use, even if such claim alleges that ON Semiconductor was negligent regarding the design or manufacture of the board.

This evaluation board/kit does not fall within the scope of the European Union directives regarding electromagnetic compatibility, restricted substances (RoHS), recycling (WEEE), FCC, CE or UL, and may not meet the technical requirements of these or other related directives.

**FCC WARNING** – This evaluation board/kit is intended for use for engineering development, demonstration, or evaluation purposes only and is not considered by ON Semiconductor to be a finished end product fit for general consumer use. It may generate, use, or radiate radio frequency energy and has not been tested for compliance with the limits of computing devices pursuant to part 15 of FCC rules, which are designed to provide reasonable protection against radio frequency interference. Operation of this equipment may cause interference with radio communications, in which case the user shall be responsible, at its expense, to take whatever measures may be required to correct this interference.

ON Semiconductor does not convey any license under its patent rights nor the rights of others.

**LIMITATIONS OF LIABILITY:** ON Semiconductor shall not be liable for any special, consequential, incidental, indirect or punitive damages, including, but not limited to the costs of requalification, delay, loss of profits or goodwill, arising out of or in connection with the board, even if ON Semiconductor is advised of the possibility of such damages. In no event shall ON Semiconductor's aggregate liability from any obligation arising out of or in connection with the board, under any theory of liability, exceed the purchase price paid for the board, if any.

For more information and documentation, please visit [www.onsemi.com](http://www.onsemi.com).

---

## PUBLICATION ORDERING INFORMATION

### LITERATURE FULFILLMENT:

Email Requests to: [orderlit@onsemi.com](mailto:orderlit@onsemi.com)

ON Semiconductor Website: [www.onsemi.com](http://www.onsemi.com)

### TECHNICAL SUPPORT

North American Technical Support:

Voice Mail: 1 800-282-9855 Toll Free USA/Canada

Phone: 011 421 33 790 2910

Europe, Middle East and Africa Technical Support:

Phone: 00421 33 790 2910

For additional information, please contact your local Sales Representative