

NOTE:

1. HOUSING MATERIAL: GLASS REINFORCED BLACK NYLON
2. TOOL WEIGHT: 32 oz.
3. INSTALLS HELLERMANN TYTON TIES T50-T255.
4. TOOL REQUIRES NO SPECIAL OPERATOR MAINTENANCE.
5. FOR REPLACEMENT BLADE ORDER PART # MK9P-109
6. SAFETY GLASSES MUST BE WORN AT ALL TIMES.
7. AIR PRESSURE: 90 PSI MAX (6 BAR)
8. USE NON-LUBRICATED AIR ONLY.
9. STANDARD = T50, T80 TIES (.18" WIDE)
HEAVY = T120(.30 WIDE), T150(.35 WIDE);
T250; T255 (.50 WIDE)
10. OPTIONAL: REMOVE PAN HEAD SCREW FROM "UNLOCK" POSITION AND PLACE IN "LOCK" POSITION TO LOCK FINE ADJUST KNOB TO CAM KNOB.

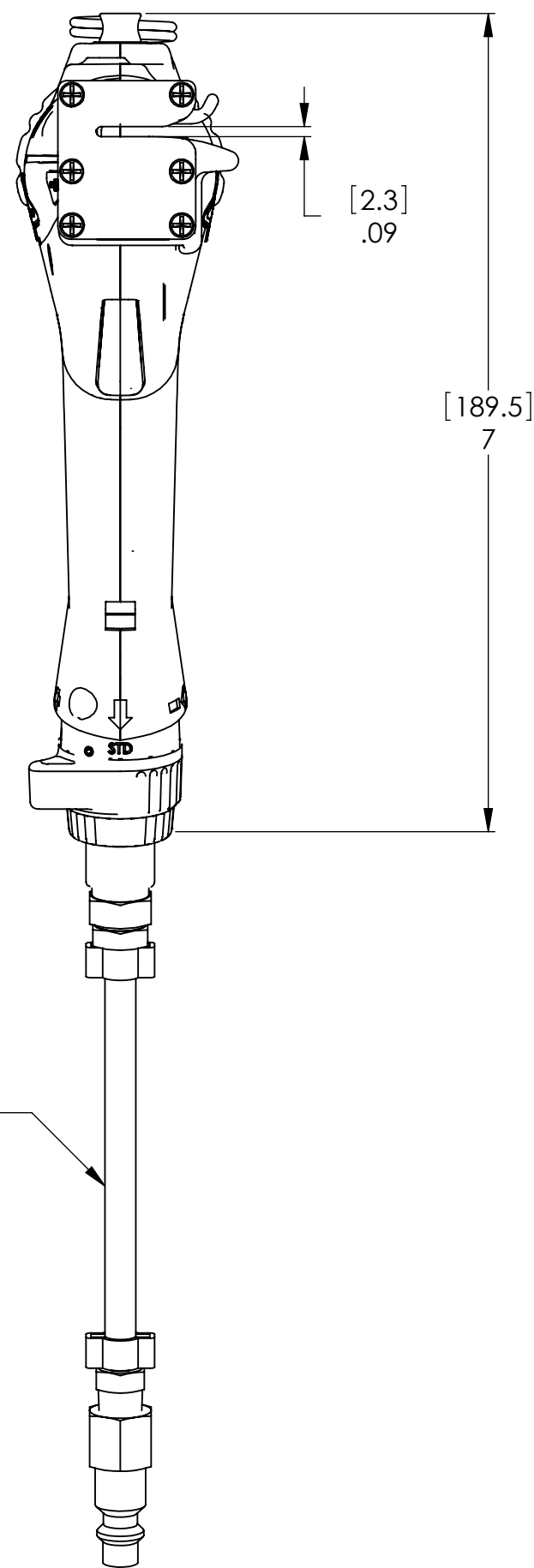

10" WHIP HOSE PROVIDED (SHORTENED FOR DRAWING FORMAT SPACE)

CAM KNOB PUSHER FOR LOW TORQUE EASE OF ADJUSTMENT

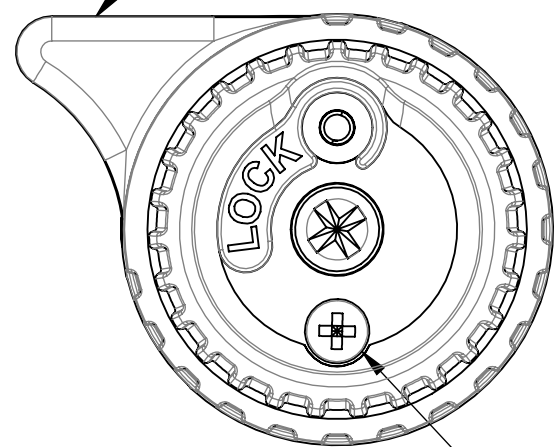

SEE NOTE 10

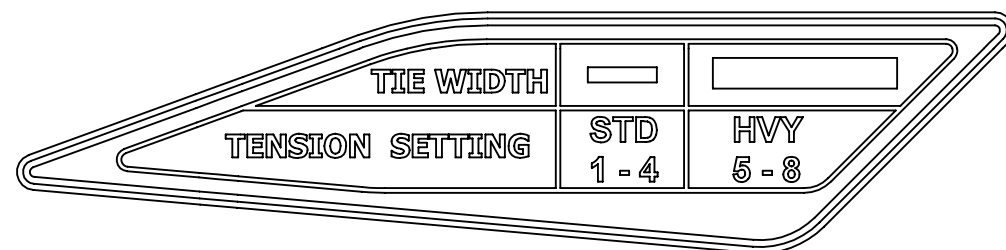

LABEL, TENSION SETTINGS SCALE 2:1



LABEL, WARNING SCALE 2:1

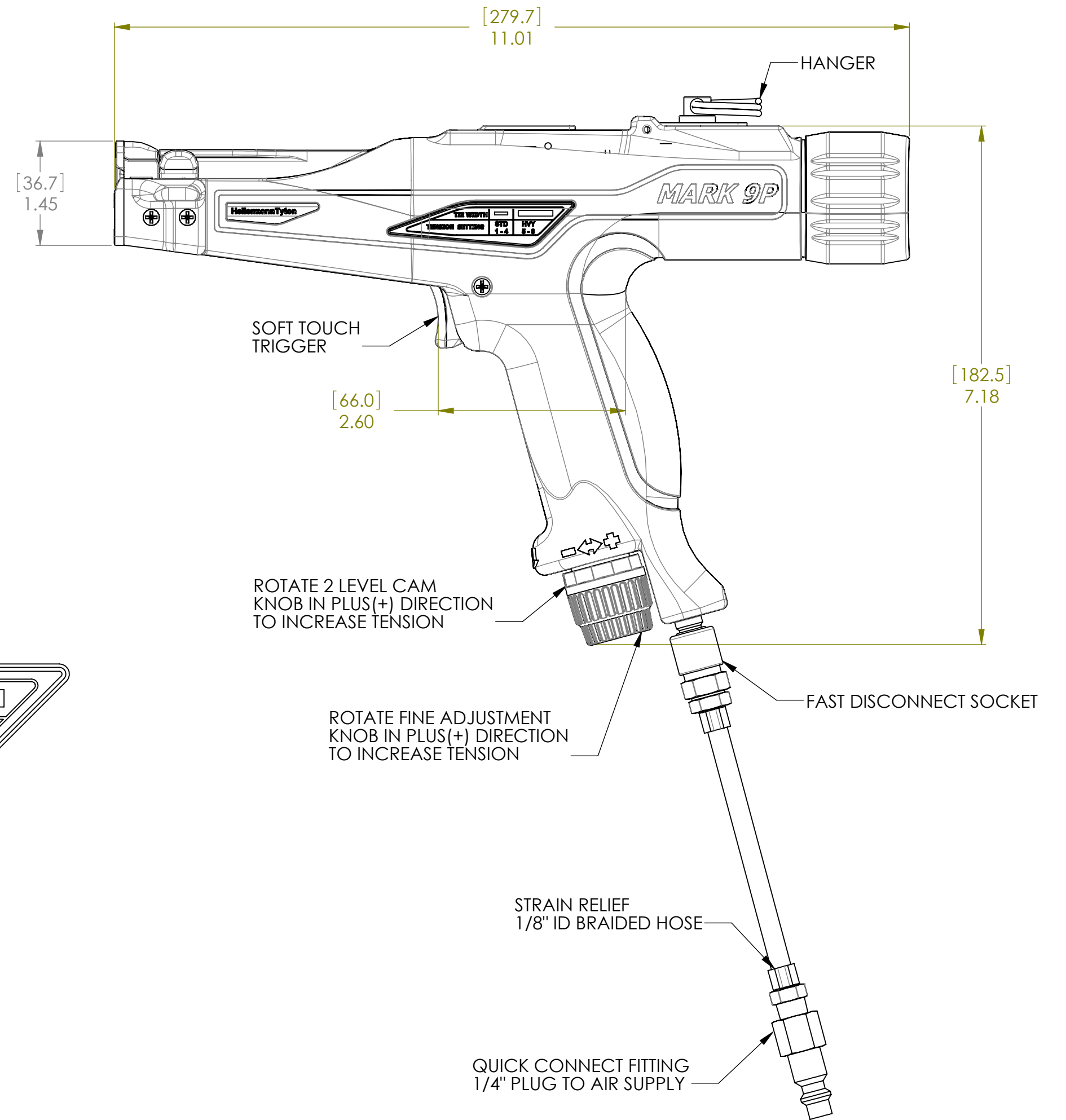
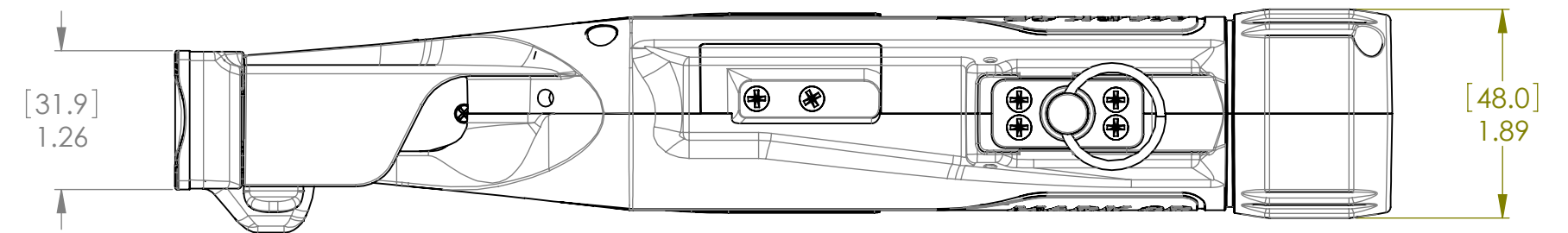

INVENTORS

HellermannTyton

ALL PROPRIETARY RIGHTS IN THE SUBJECT MATTER SHOWN ON THIS DRAWING ARE EXCLUSIVE PROPERTY OF HELLERMANN TYTON

| | | |
|------|------|-------------|
| name | date | city, state |
| | | |
| | | |

NOTES

REVISION

| | |
|------------|-----------|
| DR level | 02 |
| AW by | WKL |
| IN date | 1/11/2012 |
| NG ECN # | 012010 |
| part level | - |

TOLERANCES

.XXXX = ±.0005
.XXX = ±.005
.XX = ±.01
.X = ±.03
∠ = ±0.5°
unless otherwise specified
units inches

PART

| | | | |
|----------|-----------------------------------|-------|------------|
| number | MK9P | phase | Production |
| name | CUSTOMER DRAWING MK9P (110-09101) | | |
| material | | | |

DRAWING

| | | | | | |
|--------------------|-----------------|--------------|-------------------------|----------|-----|
| format | C | CAD | SW 2010 | scale | 4:6 |
| computer file name | TS2097100CST_02 | | previous drawing number | | |
| drawn | AAC | checked | WKL | approved | |
| date | 04/25/2007 | checked | 04/25/2007 | approved | |
| type | Customer | sheet 1 of 1 | | | |
| number | TS2097100CST | | | | |