

LOC	DIST	REVISIONS			
P	LTR	DESCRIPTION	DATE	DWN	APVD
CQ	00				
E		REVISED PER ECO-11-017085	26AUG2011	DD	RL

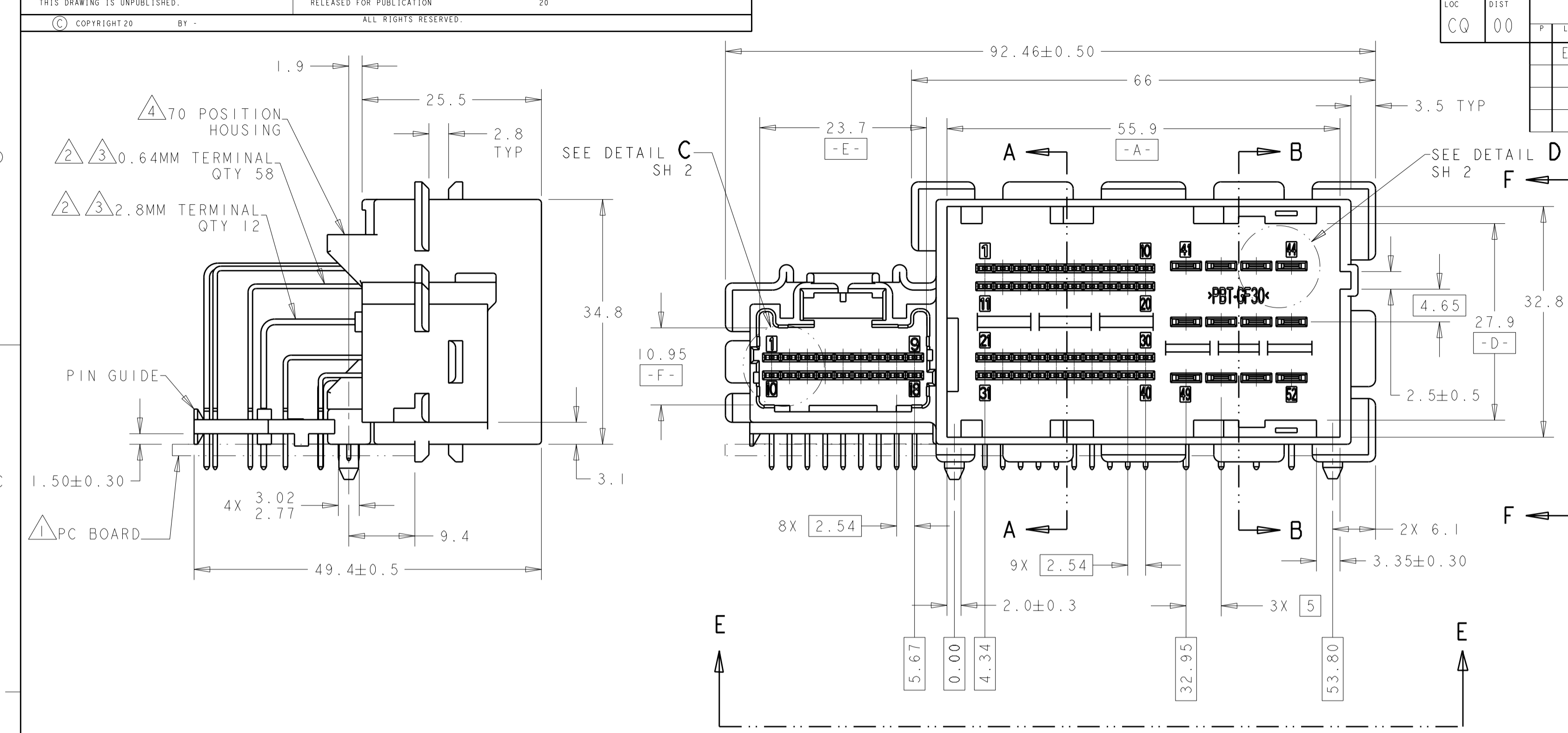

- 1 PC BOARD SUPPLIED BY CUSTOMER.
- 2 MATERIAL: BRASS, TEMPER H04.
- 3 FINISH: MATING END - 0.0008-0.0016 THICK MATTE TIN PER AMP SPEC 112-65-1. SOLDER TAIL - 0.0038-0.0064 THICK MATTE TIN PER AMP SPEC 112-65-1 ALL OVER 0.0020 MINIMUM NICKEL PER AMP SPEC 112-25-2.
- 4 MATERIAL: 30% GLASS FILLED BASF PBT.
- 5 CLEARANCE BETWEEN PC BOARD AND PIN GUIDE IS 1.75mm IN THIS AREA.
6. MINIMUM PIN RETENTION REQUIREMENT IN BOTH DIRECTIONS SHALL BE 3 TIMES THE MAXIMUM TERMINAL SEPARATION FORCE AFTER BUYER'S SOLDERING PROCESS PER DVP&R.
7. AS STITCHED, MINIMUM PIN RETENTION IN BOTH DIRECTIONS SHALL BE 40N.

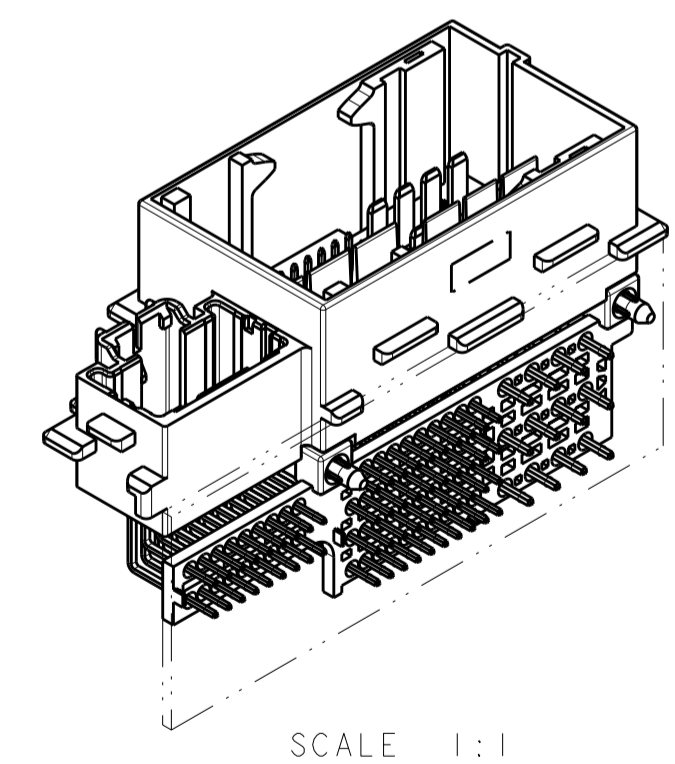
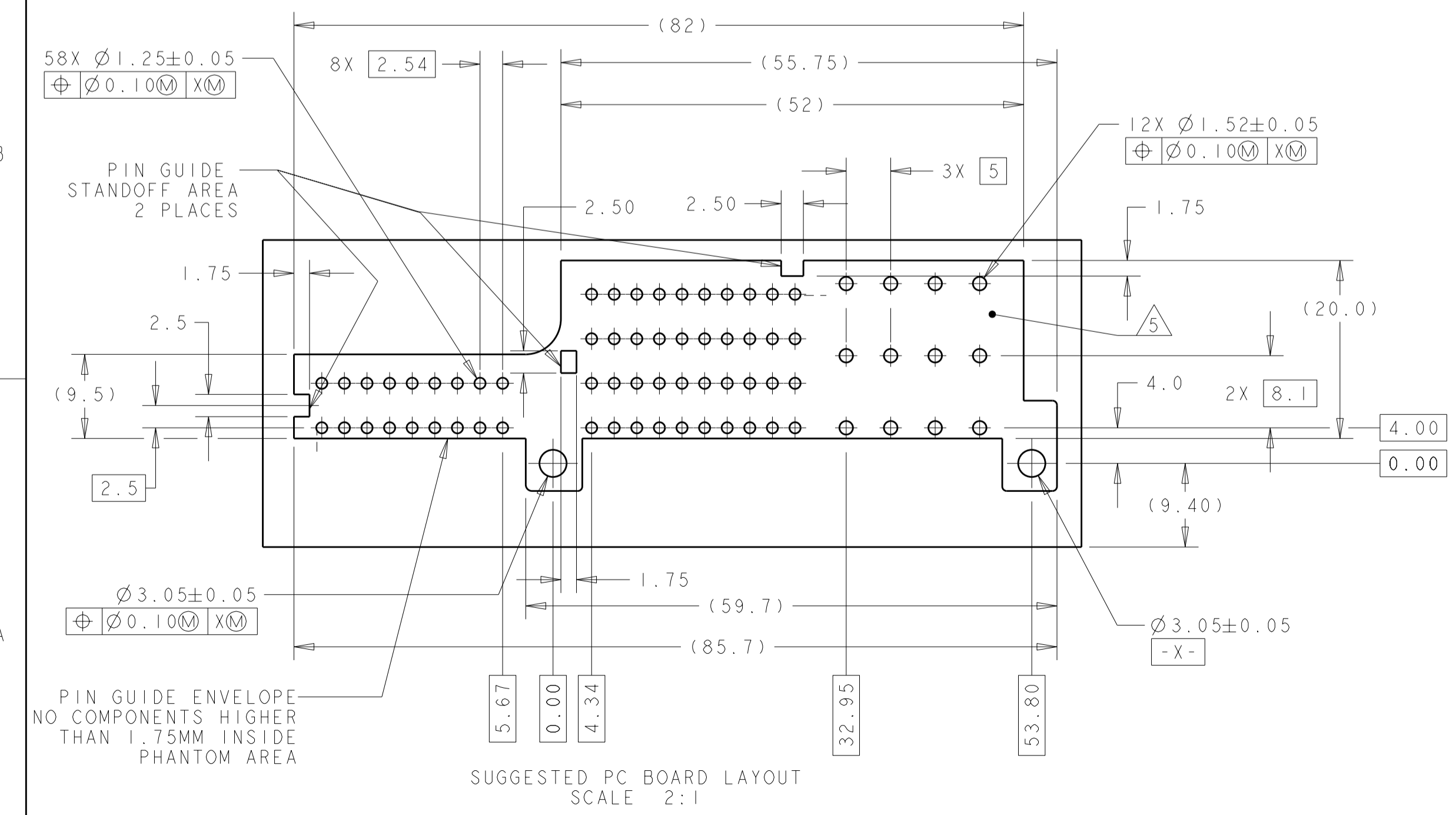

1438528-1
PART NUMBER

THIS DRAWING IS A CONTROLLED DOCUMENT.		DWN R. VESTAL 18MAR2004	TE Connectivity NAME HEADER, 70 POSITION HYBRID, 0.64mm AND 2.8mm
DIMENSIONS: mm		CHK A. EBRAHEEM 18MAR2004	
TOLERANCES UNLESS OTHERWISE SPECIFIED:		APVD A. EBRAHEEM 18MAR2004	
0 PLC ±0.5 1 PLC ±0.3 2 PLC ±0.10 3 PLC ± 4 PLC ± ANGLES ± FINISH ±		PRODUCT SPEC -	
MATERIAL -		APPLICATION SPEC -	SIZE CAGE CODE DRAWING NO RESTRICTED TO
		WEIGHT -	A260779C-1438528
		CUSTOMER DRAWING	SCALE 2:1 SHEET 1 OF 2 REV E

THIS DRAWING IS UNPUBLISHED. RELEASED FOR PUBLICATION 20
 © COPYRIGHT 20 BY - ALL RIGHTS RESERVED.

LOC	DIST	REVISIONS					
CQ	00	P	LTR	DESCRIPTION	DATE	DWN	APVD
		-		SEE SHEET 1			

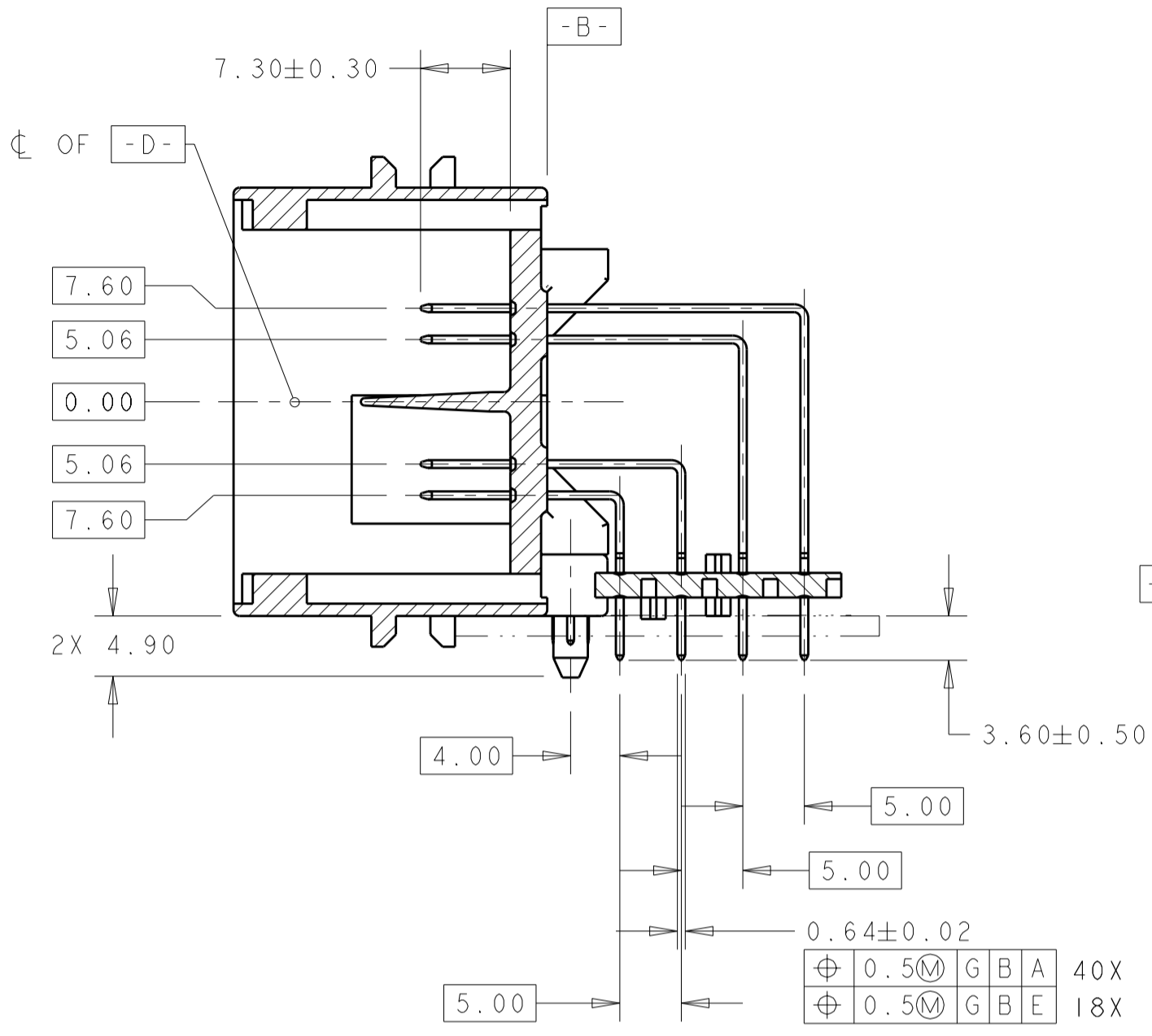

SECTION A-A
THROUGH 0.64mm BLADES

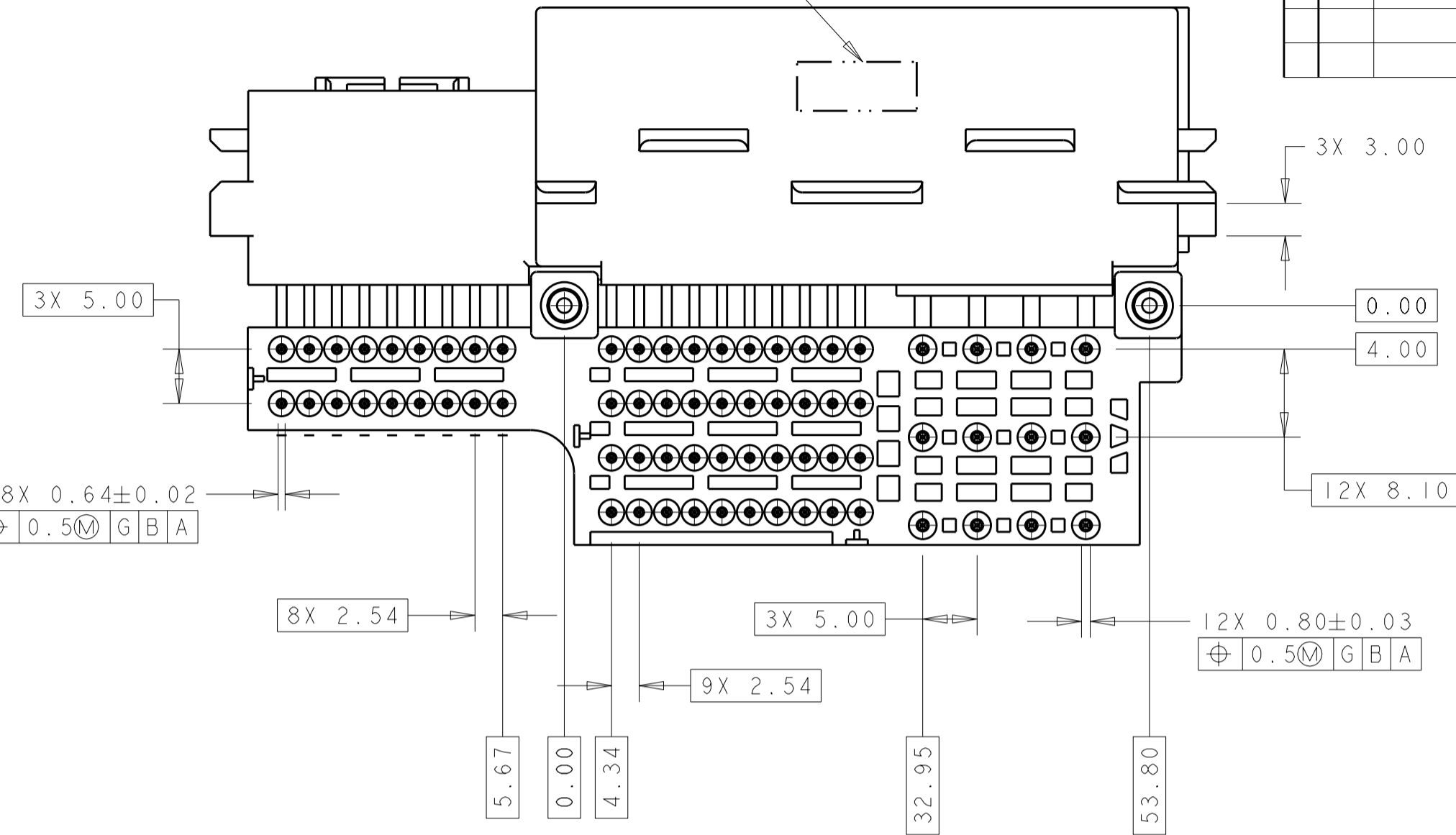

VIEW E-E

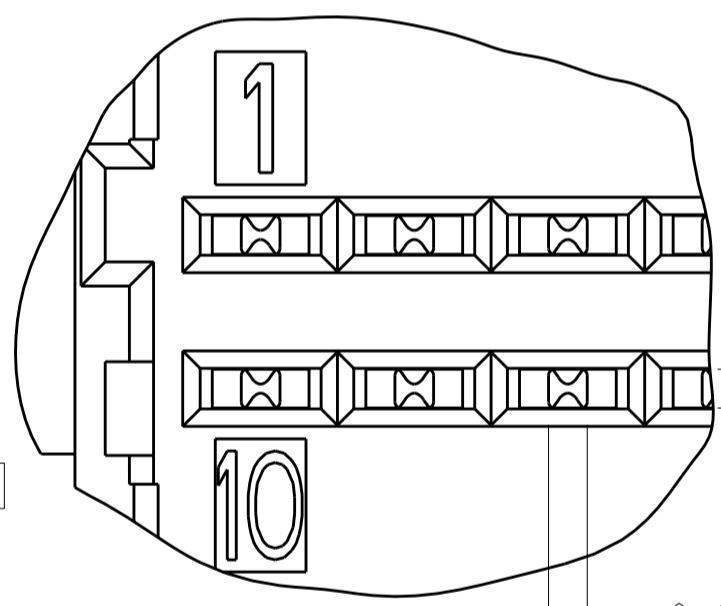

DETAIL C
SCALE 8:1

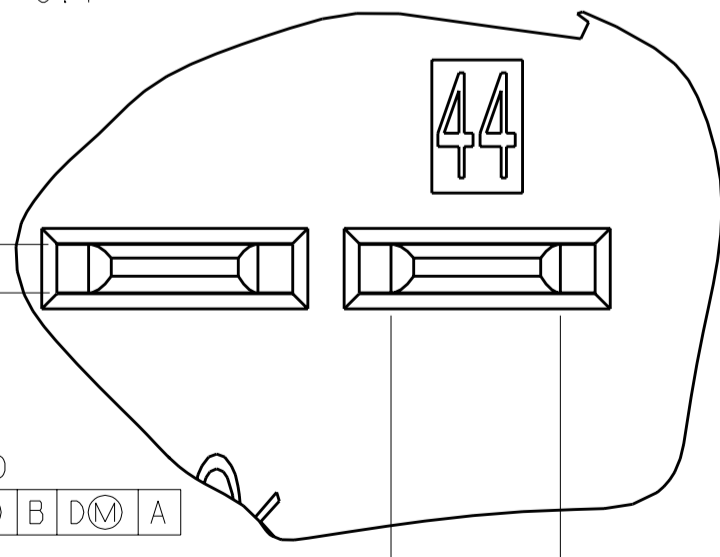

DETAIL D
SCALE 8:1

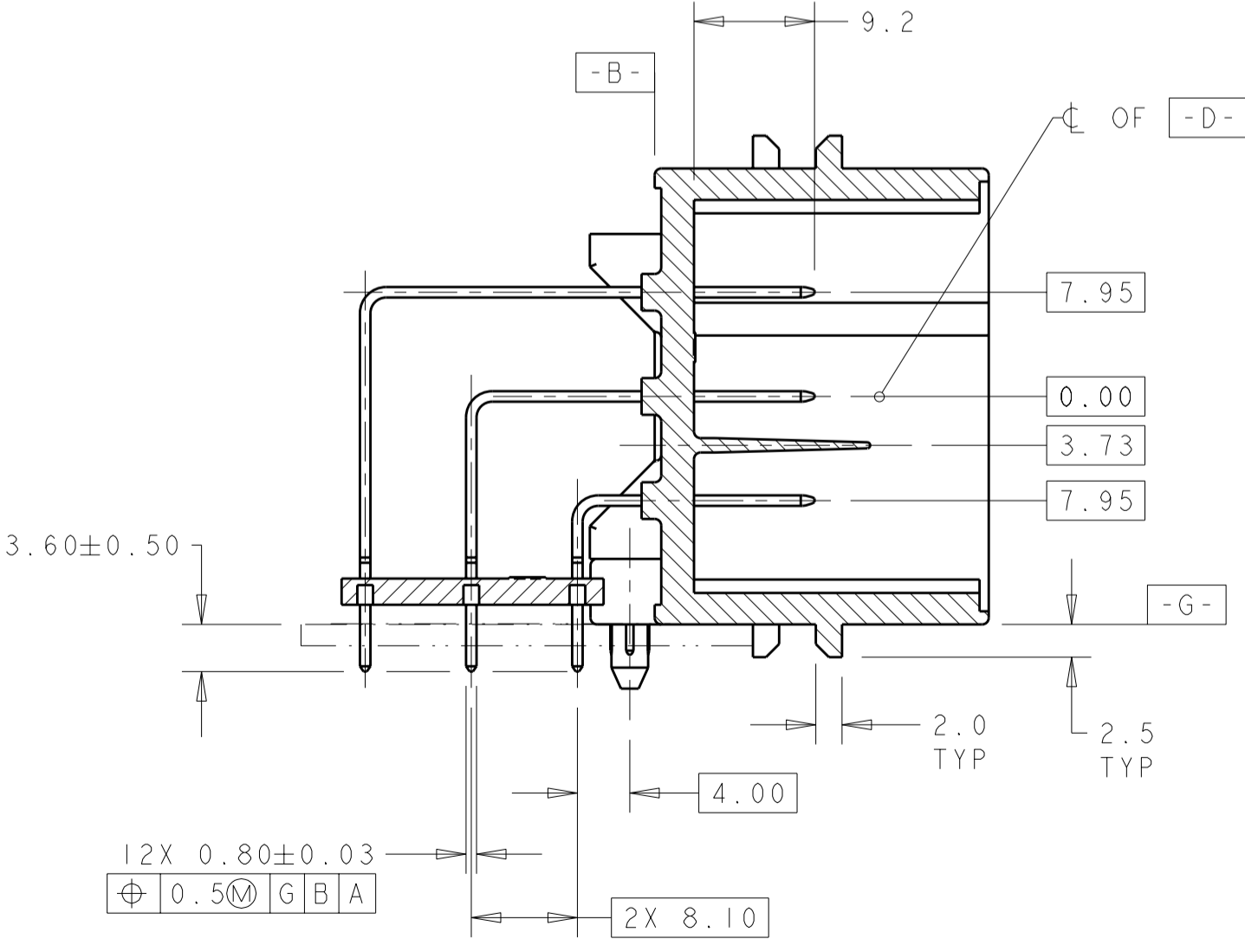

SECTION B-B
THROUGH 2.8mm BLADES

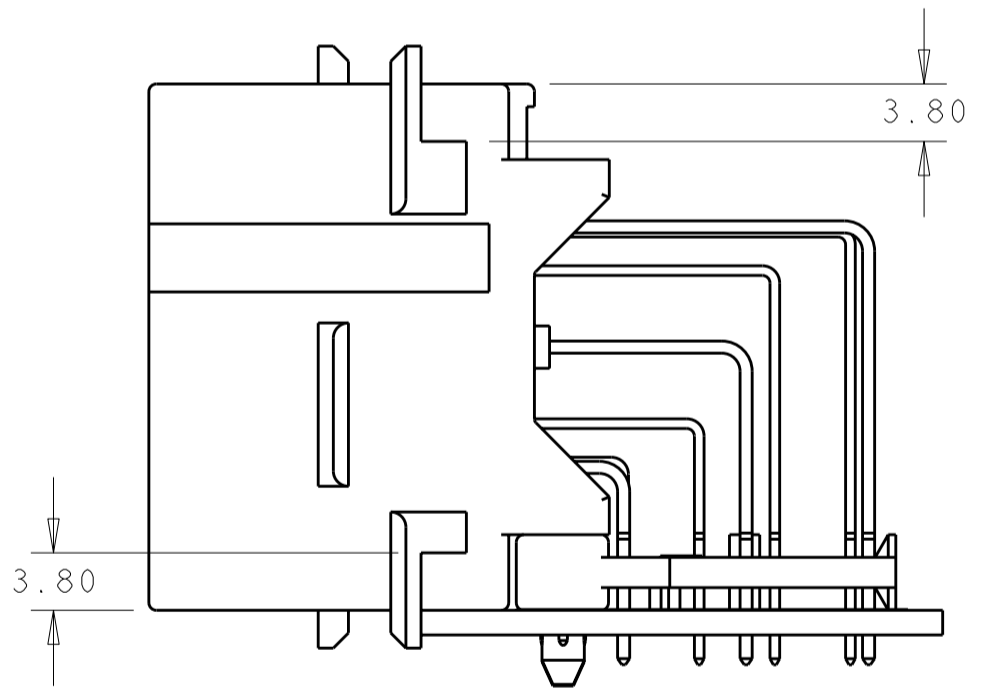

VIEW F-F

THIS DRAWING IS A CONTROLLED DOCUMENT.		DWN R. VESTAL	18MAR2004	TE Connectivity NAME HEADER, 70 POSITION HYBRID, 0.64mm AND 2.8mm SIZE CAGE CODE DRAWING NO A20779C-1438528 RESTRICTED TO -
DIMENSIONS: mm		CHK A. EBRAHEEM	18MAR2004	
TOLERANCES UNLESS OTHERWISE SPECIFIED:		APVD A. EBRAHEEM	18MAR2004	
0 PLC ±0.5 1 PLC ±0.3 2 PLC ±0.10 3 PLC ± 4 PLC ± ANGLES ± FINISH ±		PRODUCT SPEC -	APPLICATION SPEC -	
MATERIAL -		WEIGHT -		SCALE 2:1 SHEET 2 OF 2 REV E