

UNLESS NOTED:
RESISTORS: OHMS, 0402, 1%
CAPACITORS: 0603

REVISION HISTORY				
ECO	REV	DESCRIPTION	APPROVED	DATE
-	3	PRODUCTION	JIM N.	05 - 23 - 16

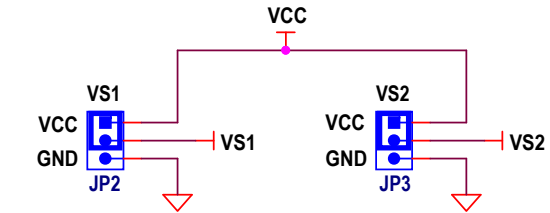
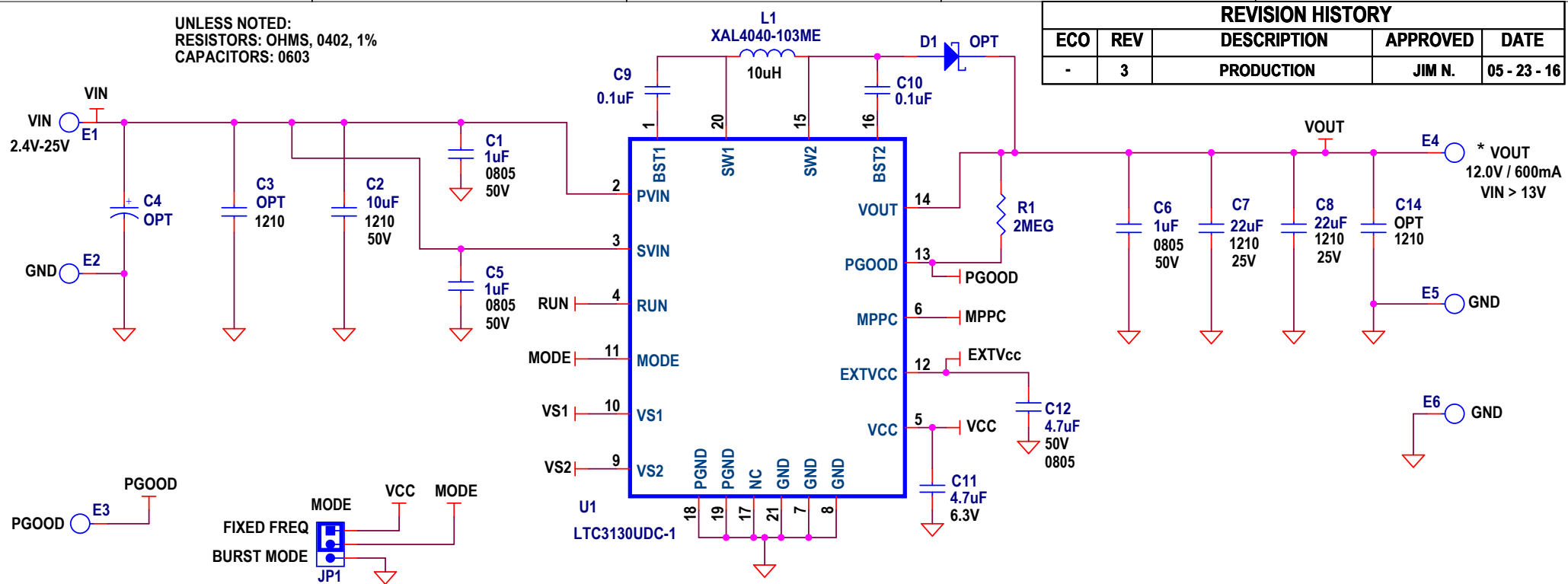

* VOUT JUMPER CONFIGURATION

JP2 / VS1	JP3 / VS2	LTC3130-1 VOUT
GND	GND	1.8V
VCC	GND	3.3V
GND	VCC	5.0V
VCC	VCC	12V

NOTES:
1) Connect GND of R3, R6, C11, C12 and C13 directly to pins 7 and 8. Connect pins 7 and 8 to IC Pad directly under IC. Connect pins 18 and 19 to copper plane and IC pad directly under IC.

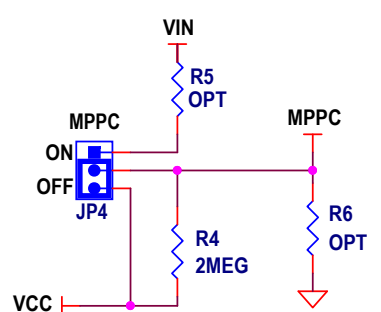

NOTE: FOR MPPC, REMOVE R4 AND POPULATE R5 AND R6. DO NOT ALLOW MPPC PIN VOLTAGE TO EXCEED 6.0V.

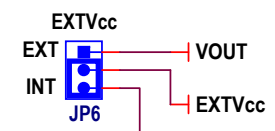

CUSTOMER NOTICE

LINEAR TECHNOLOGY HAS MADE A BEST EFFORT TO DESIGN A CIRCUIT THAT MEETS CUSTOMER-SUPPLIED SPECIFICATIONS; HOWEVER, IT REMAINS THE CUSTOMER'S RESPONSIBILITY TO VERIFY PROPER AND RELIABLE OPERATION IN THE ACTUAL APPLICATION. COMPONENT SUBSTITUTION AND PRINTED CIRCUIT BOARD LAYOUT MAY SIGNIFICANTLY AFFECT CIRCUIT PERFORMANCE OR RELIABILITY. CONTACT LINEAR TECHNOLOGY APPLICATIONS ENGINEERING FOR ASSISTANCE.

THIS CIRCUIT IS PROPRIETARY TO LINEAR TECHNOLOGY AND SUPPLIED FOR USE WITH LINEAR TECHNOLOGY PARTS.

APPROVALS

PCB DES.	NC
APP ENG.	J.NOON

LINEAR TECHNOLOGY
1630 McCarthy Blvd.
Milpitas, CA 95035
Phone: (408)432-1900 www.linear.com
Fax: (408)434-0507
LTC Confidential-For Customer Use Only

TITLE: SCHEMATIC **25V, 600mA BUCK-BOOST DC / DC CONVERTER WITH 1.6uA QUIESCENT CURRENT**

SIZE N/A IC NO. **LTC3130UDC-1 DEMO CIRCUIT 2397A** REV. **3**

DATE: 05-23-16 SHEET 1 OF 1

SCALE = NONE