

PART NUMBER	REVISION	DESCRIPTION	FEED TYPE
2150428-2	C	FINE CRIMP HEIGHT ADJUST	PNEUMATIC
7-2150428-2	C	PNEUMATIC AND CRIMP TOOLING KIT	PNEUMATIC
7-2150428-7	B	CRIMP TOOLING KIT	-

ATLANTIC VERSION TERMINATOR INTERFACE ADAPTER

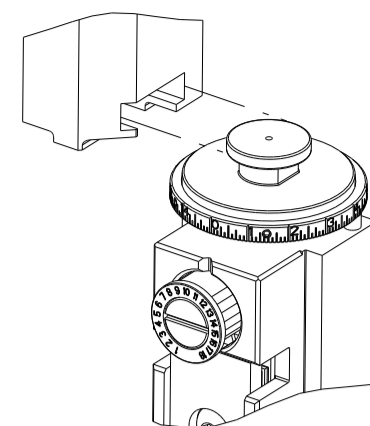

APPLICATOR DATA		
CRIMP	SIZE	TYPE
WIRE	2.29 mm [.090]	F
INSUL	3.56 mm [.140]	F

APPLICATOR INSTRUCTIONS 408-35043

TERMINAL DATA: TE TERMINAL		TE CRIMP SPECIFICATION	
TERMINAL NAME: RECEPTACLE, CLUSTER PIN, AMLIVAR, .090 DIA			
WIRE STRIP LENGTH		INSULATION DIAMETER RANGE	
7.75-8.51 mm [.305-.335 IN]		1.52-2.54 mm [.060-.100 IN]	
TERMINAL APPLICATION SPECIFICATION	114-2019	-	-
TERMINALS APPLIED			
TE TERMINAL	TE TERMINAL	TE TERMINAL	TE TERMINAL
1742981-1	2378865-1		

WIRE SIZE	CRIMP HEIGHT mm [INCH]	CRIMP HEIGHT REFERENCE SETTING
1600 CMA	1.27 +/- 0.05 [.050 +/- .002]	7.6
400 CMA	1.07 +/- 0.05 [.042 +/- .002]	9.6

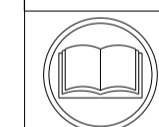

1. RECOMMENDED SPARE PARTS.
2. REFER TO SUPPLIED INSTRUCTION SHEET FOR CLEANING, LUBRICATION AND STORAGE OF APPLICATOR.
3. APPLY PART NUMBER 2-23419-6 LOCTITE TO THREADS OF ITEM 242.
4. CRIMP HEIGHT REFERENCE SETTING WAS THE SETTING USED WHEN THE APPLICATOR WAS QUALIFIED AT THE FACTORY. ADJUSTMENT MAY BE NECESSARY WHEN RUNNING APPLICATOR IN THE FIELD.
5. TERMINAL PITCH NOT COMPATIBLE WITH MECHANICAL FEED.
6. FEED TERMINAL OFF OF RECEPTACLE.
7. RECOMMENDED SET-UP WIRE FOR QUALIFICATION ONLY AT THE FACTORY.
8. REFER TO APPLICATION SPECIFICATION FOR ADDITIONAL WIRE CRIMP HEIGHTS.
9. UNLESS SPECIFIED OTHERWISE TORQUE VALUES SHALL BE USED PER DOCUMENT, 101-35000.

***WARNING**
ON INSTALLATION, SET WIRE DISC TO CRIMP HEIGHT REFERENCE SETTING FOR LARGEST WIRE SIZE. CRIMP HEIGHT REFERENCE SETTINGS GREATER THAN THE VALUE SHOWN MAY CAUSE DAMAGE TO THE CRIMP TOOLING, REFER TO THE INSTRUCTION SHEET FOR PROPER SETUP AND ADJUSTMENTS.

ATLANTIC VERSION
Shown on sheets 1 of 4 & 2 of 4
(Pacific version shown on sheets 3 of 4 & 4 of 4)

LOC	DIST	REVISIONS					
		P	LTN	DESCRIPTION	DATE	OWN	APVD
A	66	A		RELEASED	12JUN2014	BH	GB
		B		ECR-18-010215	02JUL2018	AW	CT
		C		ECR-22-153175	20SEP2022	LG	TE

-	1	1	2119641-1	FEED CAM, AIR FEED	248
-	1	1	2119082-4	CAM, SNAIL, INSULATION ADJUSTMENT	244
-	1	1	2079764-1	WASHER, WAVE SPRING, CREST-TO-CREST	243
-	1	1	2119083-1	RETAINER, INSULATION DIAL	242
-	1	1	2844940-3	AIR FEED MODULE	238
-	1	1	1-18028-0	WASHER, FLAT, REG M8	192
-	REF	REF	994970-2	COUNTER, MAGNETIC	164
-	1	1	455888-4	SPACER, CRIMPER	82
-	1	1	1803607-4	DOCUMENTATION PACKAGE	71
-	2	2	2-18032-2	SCR, SET, FLT PNT, M3 X 10.0	70
-	1	1	2119740-1	TAG, IDENTIFICATION	67
-	2	2	2168078-1	SCREW, DRIVE, RH, RoHS, 2 x .188	66
-	1	1	2168083-2	SCR, SKT HD CAP, RoHS, M4 X 8.0	60
-	1	1	5-18022-5	SCR, HEX HD CAP, M4 X 6.0	59
-	4	4	2168400-4	SHCS, LOW HEAD, RoHS, M4 X 8	57
-	2	2	1-2168083-0	SCR, SKT HD CAP, RoHS, M4 X 10	56
-	2	2	5018030-1	NUT, HEX, REG, RoHS, M3	54
-	2	2	986965-8	NUT, LOCK, HEX, TORQUE (M4)	53
-	1	1	2063961-1	FEED FINGER	51
-	1	1	18023-9	SCR, SKT HD CAP M4 X 6.0	49
-	1	1	2119655-5	APPLICATOR BASIC ASSEMBLY, EF	46
-	1	1	1803517-1	RAM ASSEMBLY, EF ATLANTIC	44
-	1	1	1803602-1	SCR, BHSC, RoHS (M8 X 25)	41
-	8	8	1-18028-2	WASHER, FLAT, REG M4	33
-	2	2	2168083-9	SCR, SKT HD CAP, RoHS, M4 X 20	31
-	2	2	2168083-2	SCR, SKT HD CAP, RoHS, M4 X 8.0	29
-	1	1	240639-2	STRIPPER (MACHINING)	27
-	2	2	1-2168083-5	SCR, SKT HD CAP, RoHS, M4 X 30	25
-	1	1	1752371-5	PLATE, STRIP GUIDE	24
-	2	2	2-22281-3	SPRING, COMPRESSION	22
-	1	1	1803292-4	DRAG	20
-	2	2	1901259-5	GUIDE, LOWER STRIP	18
-	4	4	1-2079383-1	SCR, BHSC, RoHS (M6 X 12)	17
-	1	1	217573-3	TOOL, SIZING	15
-	1	1	240644-1	PLATE, REAR SHEAR	11
-	-	-	-	-	10
-	1	1	2-690482-9	PLATE, FRONT SHEAR	9
1	2	1	819517-5	ANVIL, COMBINATION	8
-	1	1	1-2217206-3	BLADE, SLUG	7
-	-	-	-	-	6
-	1	1	4-240641-8	SPACER	5
-	1	1	238011-2	BLOCK, CRIMPER SPACER	4
1	2	1	5-2119582-2	CRIMPER, INSULATION F PREMIUM	3
-	1	1	455888-7	SPACER, CRIMPER	2
1	2	1	819516-7	CRIMPER, WIRE	1
-	77	72	-2	PART NO	ITEM NO
				DESCRIPTION	

DIMENSIONS:		TOLERANCES UNLESS OTHERWISE SPECIFIED:		MATERIAL:		FINISH:		WEIGHT:		SCALE:		SHEET:		REV:	
mm	0 PLC ±	1 PLC ±	2 PLC ±	3 PLC ±	4 PLC ±	ANGLES	FINISH			A	00779	C=2150428	1	4	C

LOC	DIST	REVISIONS					
		P	LTN	DESCRIPTION	DATE	OWN	APVD
A	66	-	-	SEE SHEET 1	-	-	-

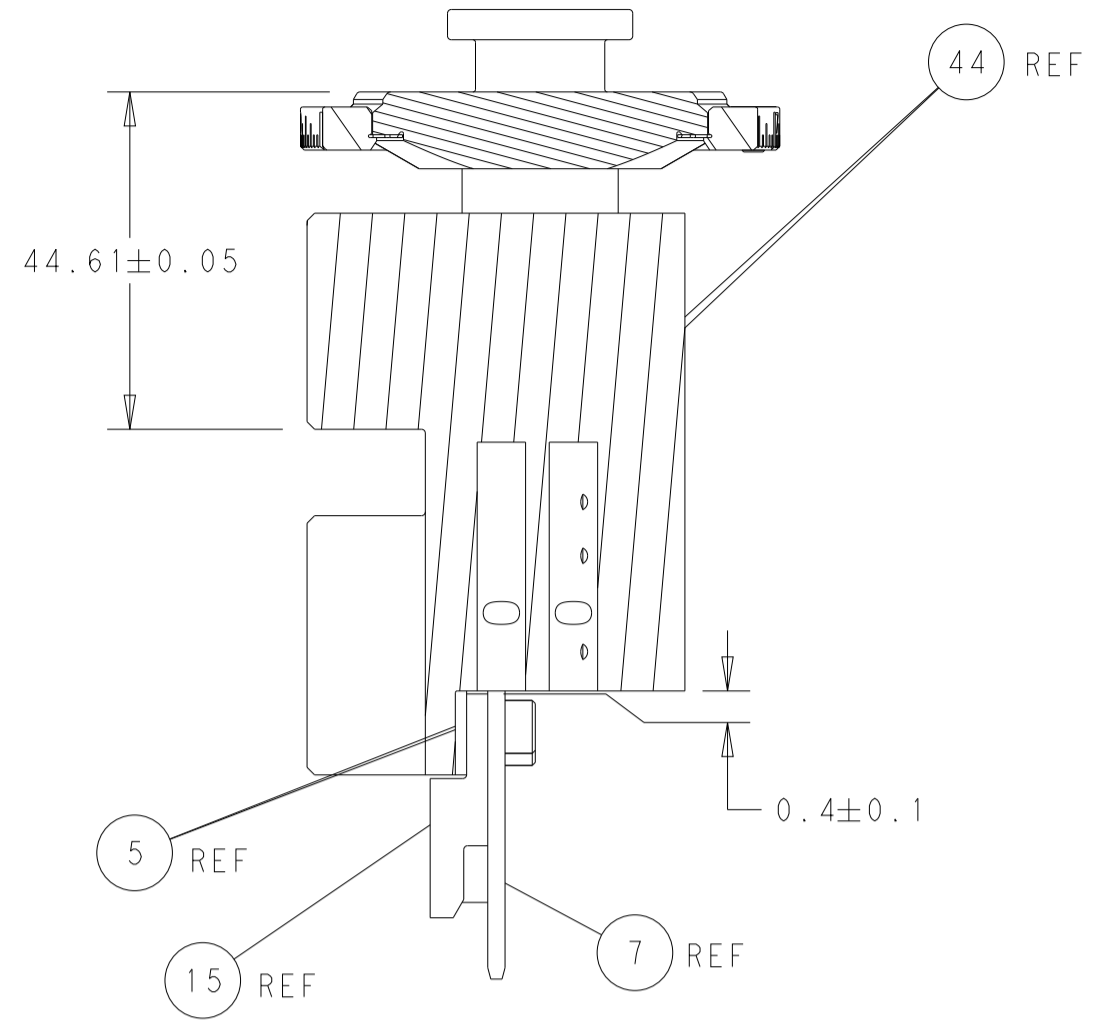

RAM AND SIZING TOOL SET-UP

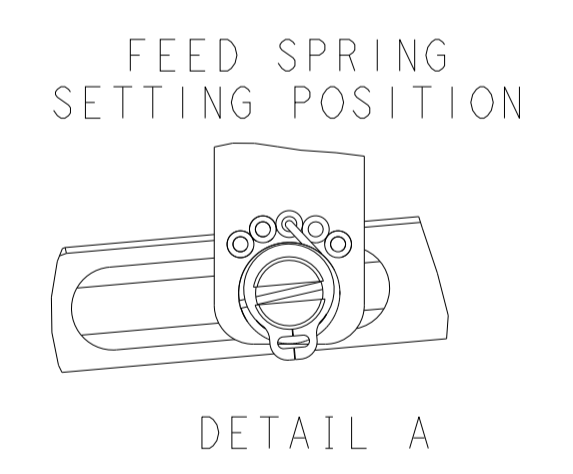
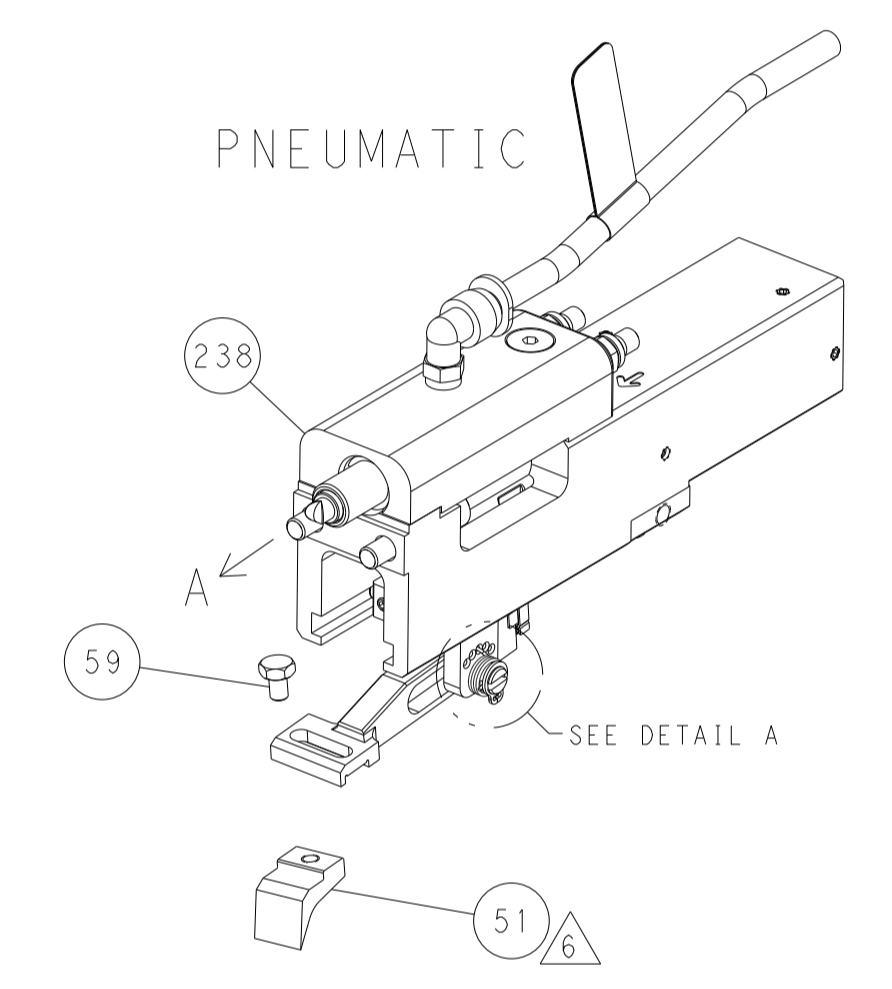
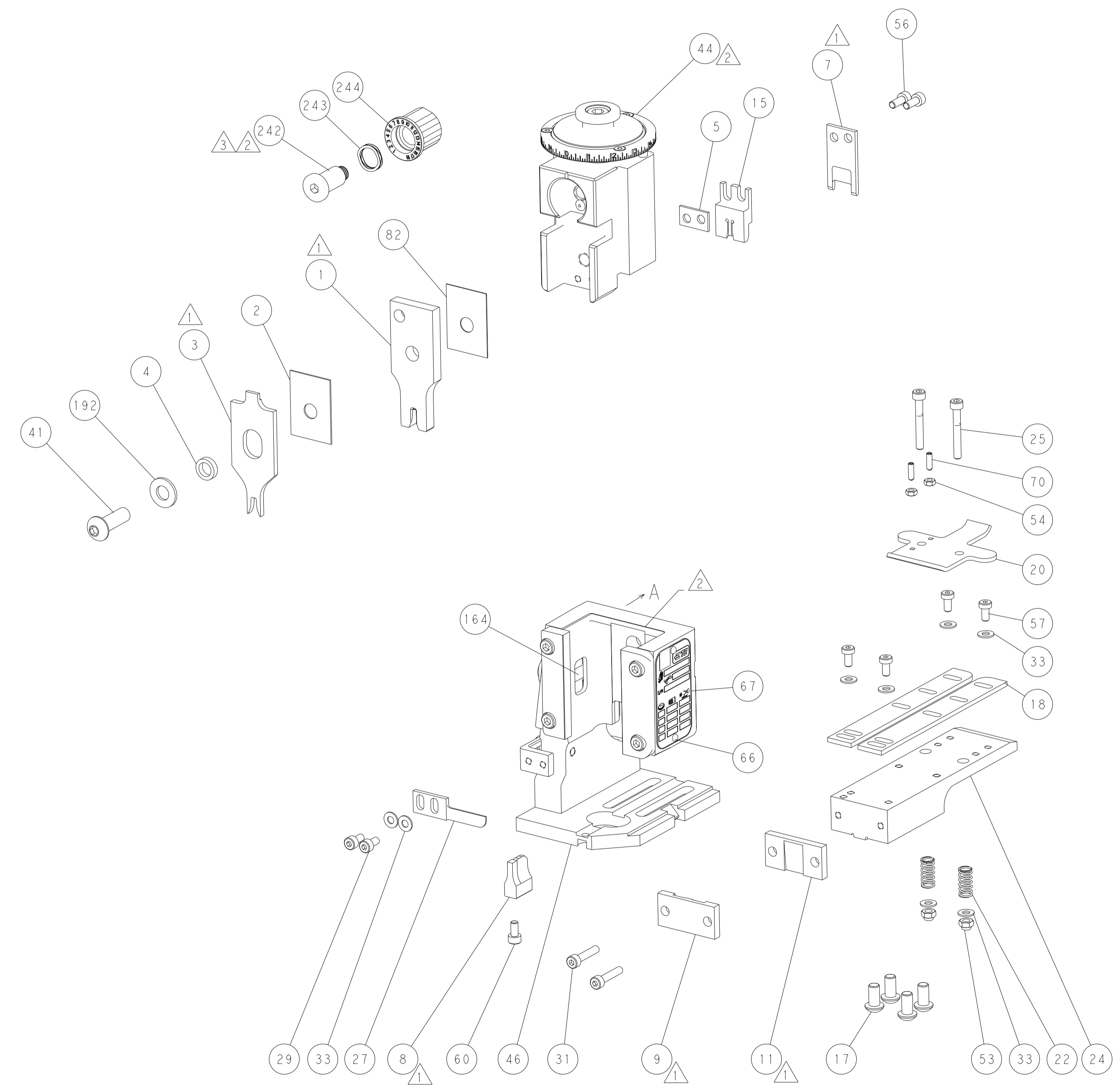

CAM POSITION

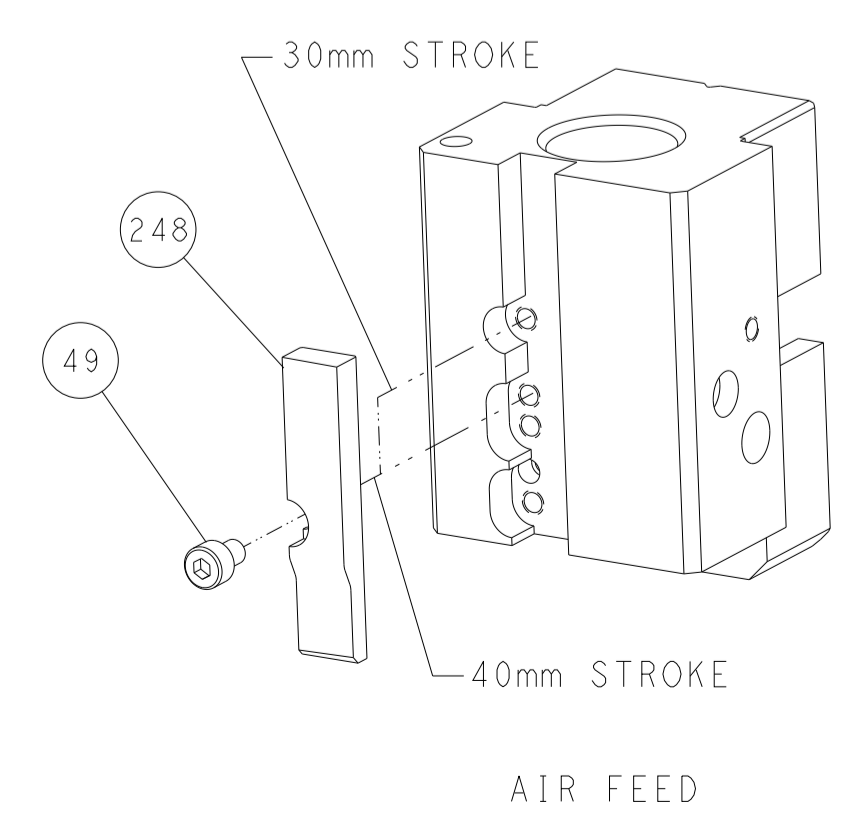

ATLANTIC VERSION
 Shown on sheets 1 of 4 & 2 of 4
 (Pacific version shown on sheets 3 of 4 & 4 of 4)

<small>THIS DRAWING IS UNPUBLISHED. RELEASED FOR PUBLICATION BY TYCO ELECTRONICS CORPORATION. ALL RIGHTS RESERVED.</small>		DWN BOB HIGMAN 15APR2014 CHK G. BAILEY 15APR2014 APVD G. BAILEY 15APR2014	NAME Ocean End Feed Applicator SIZE CAGE CODE DRAWING NO. A1 00779 C=2150428 RESTRICTED TO
DIMENSIONS: mm TOLERANCES UNLESS OTHERWISE SPECIFIED: 0 PLC ± 1 PLC ± 2 PLC ± 3 PLC ± 4 PLC ± ANGLES ± FINISH	TOLERANCES UNLESS OTHERWISE SPECIFIED: 0 PLC ± 1 PLC ± 2 PLC ± 3 PLC ± 4 PLC ± ANGLES ± FINISH	PRODUCT SPEC APPLICATION SPEC WEIGHT SCALE 1:1 SHEET 2 OF 4 REV C	CUSTOMER ACCESSIBLE PRODUCTION DRAWING

PART NUMBER	REVISION	DESCRIPTION	FEED TYPE
2-2150428-2	C	FINE CRIMP HEIGHT ADJUST	PNEUMATIC
7-2150428-7	B	CRIMP TOOLING KIT	-

PACIFIC VERSION TERMINATOR
 INTERFACE ADAPTER

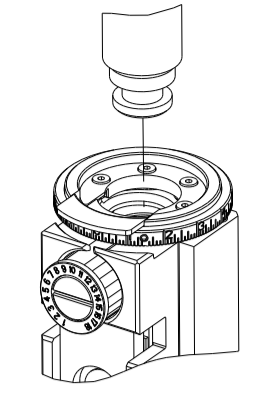

APPLICATOR DATA		
CRIMP	SIZE	TYPE
WIRE	2.29 mm (.090)	F
INSUL	3.56 mm (.140)	F
APPL INSTRUCTIONS 408-35043		

TERMINAL DATA: TE TERMINAL		TE CRIMP SPECIFICATION	
TERMINAL NAME: RECEPTACLE, CLUSTER PIN, AMLIVAR, .090 DIA			
WIRE STRIP LENGTH		INSULATION DIAMETER RANGE	
7.75-8.51 mm (.305-.335 IN)		Ø1.52-2.54 mm (.060-.100 IN)	
TERMINAL APPLICATION SPECIFICATION	114-2019		
TERMINALS APPLIED			
TE TERMINAL	TE TERMINAL	TE TERMINAL	TE TERMINAL
1742981-1	2378865-1		

WIRE SIZE	CRIMP HEIGHT mm [INCH]	CRIMP HEIGHT REFERENCE SETTING
1600 CMA	1.27+/-0.05 [.050+/-0.002]	7.6
400 CMA	1.07+/-0.05 [.042+/-0.002]	9.6



- 1 RECOMMENDED SPARE PARTS.
- 2 REFER TO SUPPLIED INSTRUCTION SHEET FOR CLEANING, LUBRICATION AND STORAGE OF APPLICATOR.
- 3 APPLY PART NUMBER 2-23419-6 LOCTITE TO THREADS OF ITEM 242.
- 4 CRIMP HEIGHT REFERENCE SETTING WAS THE SETTING USED WHEN THE APPLICATOR WAS QUALIFIED AT THE FACTORY. ADJUSTMENT MAY BE NECESSARY WHEN RUNNING APPLICATOR IN THE FIELD.
- 5 TERMINAL PITCH NOT COMPATIBLE WITH MECHANICAL FEED.
- 6 FEED TERMINAL OFF OF RECEPTACLE.
- 7 RECOMMENDED SET-UP WIRE FOR QUALIFICATION ONLY AT THE FACTORY.
- 8 REFER TO APPLICATION SPECIFICATION FOR ADDITIONAL WIRE CRIMP HEIGHTS.
- 9. UNLESS SPECIFIED OTHERWISE TORQUE VALUES SHALL BE USED PER DOCUMENT, 101-35000.

***WARNING**
 ON INSTALLATION, SET WIRE DISC TO CRIMP HEIGHT REFERENCE SETTING FOR LARGEST WIRE SIZE. CRIMP HEIGHT REFERENCE SETTINGS GREATER THAN THE VALUE SHOWN MAY CAUSE DAMAGE TO THE CRIMP TOOLING, REFER TO THE INSTRUCTION SHEET FOR PROPER SETUP AND ADJUSTMENTS.

PACIFIC VERSION
 Shown on sheets 3 of 4 & 4 of 4
 (Atlantic version shown on sheets 1 of 4 & 2 of 4)

LOC	DIST	REVISIONS					
A	66	P	LTN	DESCRIPTION	DATE	OWN	APVD
		-		SEE SHEET 1			

-	1	2119082-4	CAM, SNAIL, INSULATION ADJUSTMENT	244
-	1	2079764-1	WASHER, WAVE SPRING, CREST-TO-CREST	243
-	1	2119083-1	RETAINER, INSULATION DIAL	242
-	1	2844940-3	AIR FEED MODULE	238
-	1	1-18028-0	WASHER, FLAT, REG M8	192
-	4	2079383-9	SCR, BHSC, RoHS (M6 X 20)	186
-	REF	994970-2	COUNTER, MAGNETIC	164
-	1	2119641-2	FEED CAM, AIR FEED	152
-	1	2168083-8	SCR, SKT HD CAP, RoHS, M4 X 16	144
-	1	2119655-6	APPLICATOR BASIC ASSEMBLY, EF	141
-	1	1803518-1	RAM ASSEMBLY, EF PACIFIC	140
-	1	455888-4	SPACER, CRIMPER	82
-	1	1803607-4	DOCUMENTATION PACKAGE	71
-	2	2-18032-2	SCR, SET, FLT PNT, M3 X 10.0	70
-	1	2119740-1	TAG, IDENTIFICATION	67
-	2	2168078-1	SCREW, DRIVE, RH, RoHS, 2 x .188	66
-	1	5-18022-5	SCR, HEX HD CAP, M4 X 6.0	59
-	4	2168400-4	SHCS, LOW HEAD, RoHS, M4 X 8	57
-	2	1-2168083-0	SCR, SKT HD CAP, RoHS, M4 X 10	56
-	2	5018030-1	NUT, HEX, REG, RoHS, M3	54
-	2	986965-8	NUT, LOCK, HEX, TORQUE (M4)	53
-	1	2063961-1	FEED FINGER	51
-	1	18023-9	SCR, SKT HD CAP M4 X 6.0	49
-	1	1803602-1	SCR, BHSC, RoHS (M8 X 25)	41
-	8	1-18028-2	WASHER, FLAT, REG M4	33
-	2	2168083-9	SCR, SKT HD CAP, RoHS, M4 X 20	31
-	2	2168083-2	SCR, SKT HD CAP, RoHS, M4 X 8.0	29
-	1	240639-2	STRIPPER (MACHINING)	27
-	2	1-2168083-5	SCR, SKT HD CAP, RoHS, M4 X 30	25
-	1	1752371-5	PLATE, STRIP GUIDE	24
-	2	2-22281-3	SPRING, COMPRESSION	22
-	1	1803292-4	DRAG	20
-	2	1901259-5	GUIDE, LOWER STRIP	18
-	1	217573-3	TOOL, SIZING	15
-	1	240644-1	PLATE, REAR SHEAR	11
-	-	-	-	10
-	1	2-690482-9	PLATE, FRONT SHEAR	9
-	1	819517-5	ANVIL, COMBINATION	8
-	1	1-2217206-3	BLADE, SLUG	7
-	-	-	-	6
-	1	4-240641-8	SPACER	5
-	1	238011-2	BLOCK, CRIMPER SPACER	4
-	1	5-2119582-2	CRIMPER, INSULATION F PREMIUM	3
-	1	455888-7	SPACER, CRIMPER	2
-	1	819516-7	CRIMPER, WIRE	1
-	77-22	PART NO	DESCRIPTION	ITEM NO

DIMENSIONS: mm		TOLERANCES UNLESS OTHERWISE SPECIFIED:		DWG: BOB HIGMAN 15APR2014		CHK: G. BAILEY 15APR2014		NAME: STE TE Connectivity Harrisburg, PA 17105-3608	
0 PLC ±		1 PLC ±		APVD: G. BAILEY 15APR2014		PRODUCT SPEC		SIZE: A1	
2 PLC ±		3 PLC ±		APPLICATION SPEC		CAGE CODE: 00779		DRAWING NO: C=2150428	
4 PLC ±		ANGLES FINISH		WEIGHT		SCALE: 1:1		SHEET 3 OF 4	
MATERIAL		FINISH		CUSTOMER ACCESSIBLE PRODUCTION DRAWING		SCALE: 1:1		REV C	

LOC		DIST		REVISIONS			
P	LTN	DESCRIPTION	DATE	OWN	APVD		
-	-	SEE SHEET 1	-	-	-		

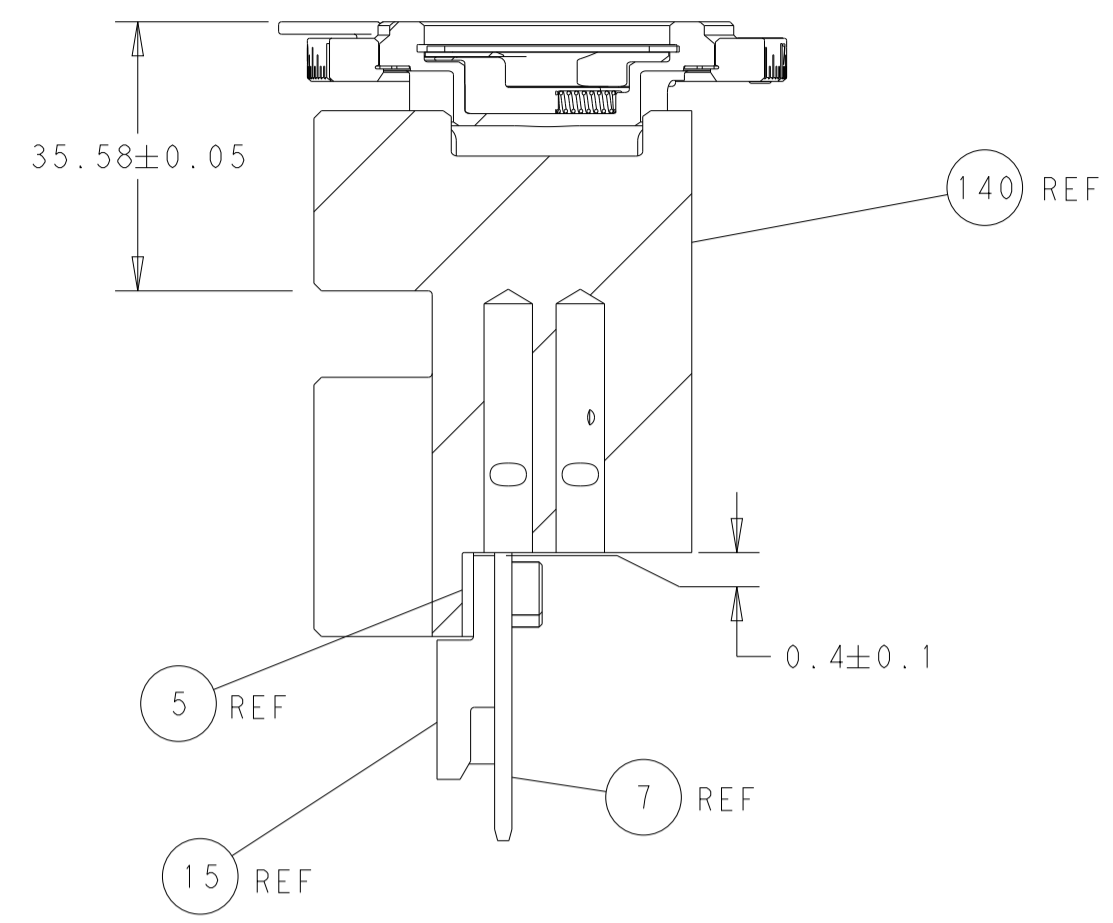

RAM AND SIZING TOOL SET-UP

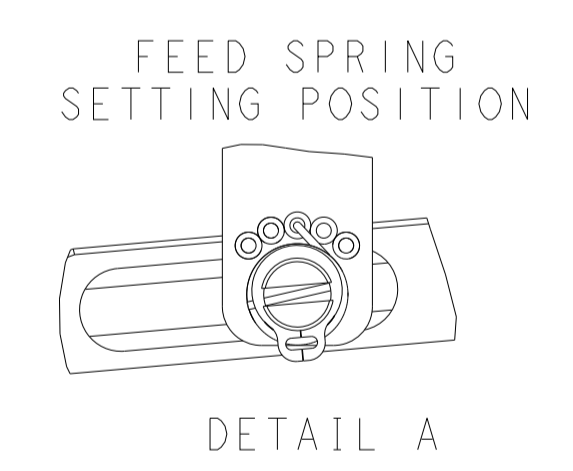
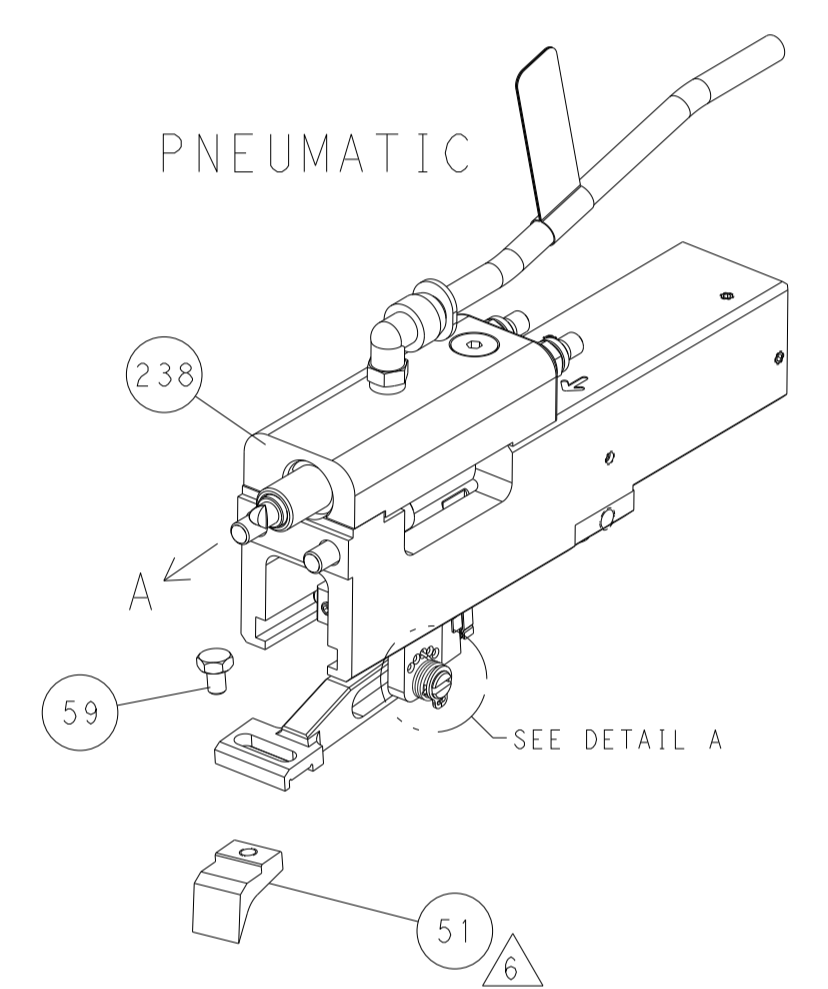
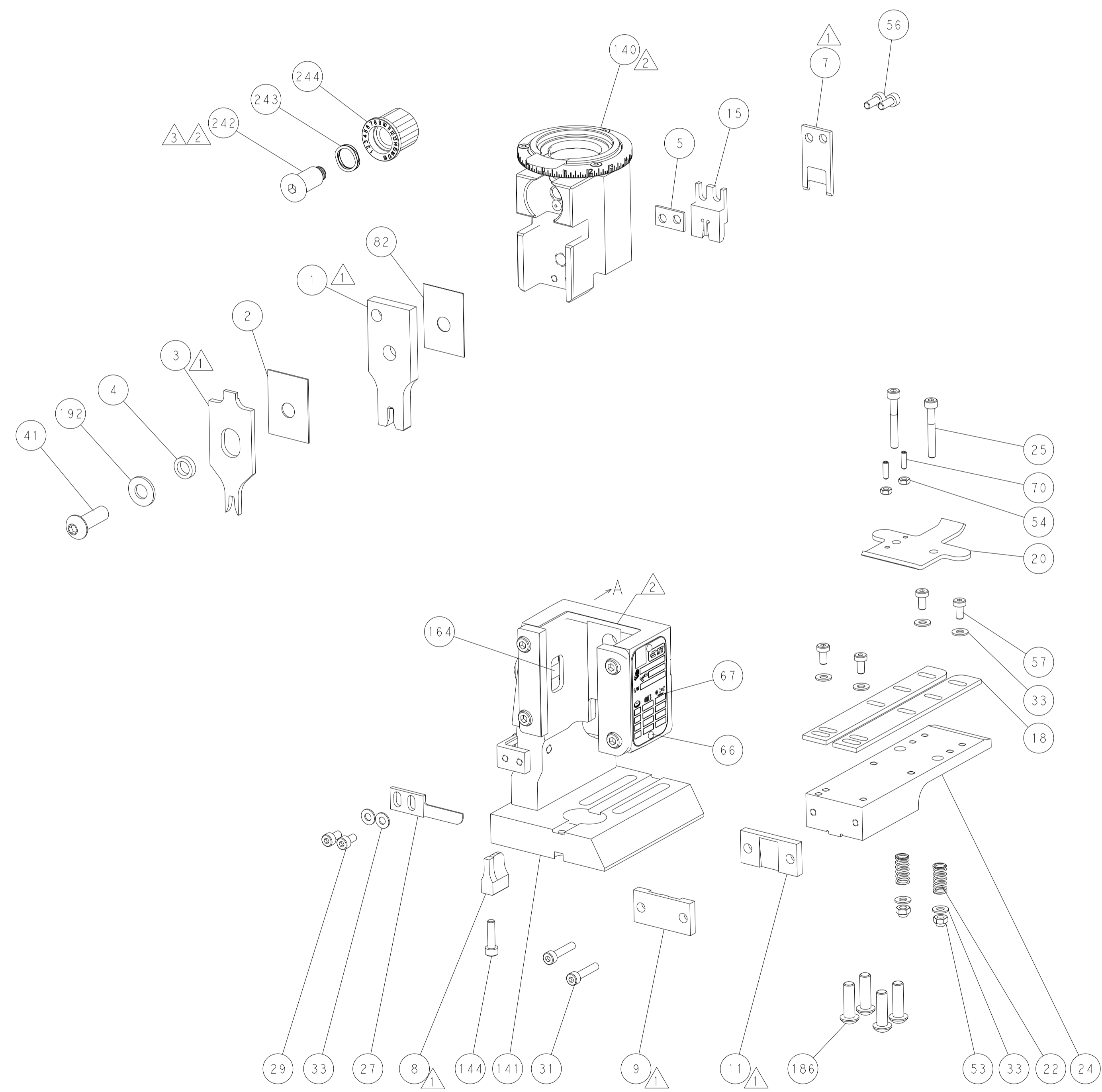

CAM POSITION

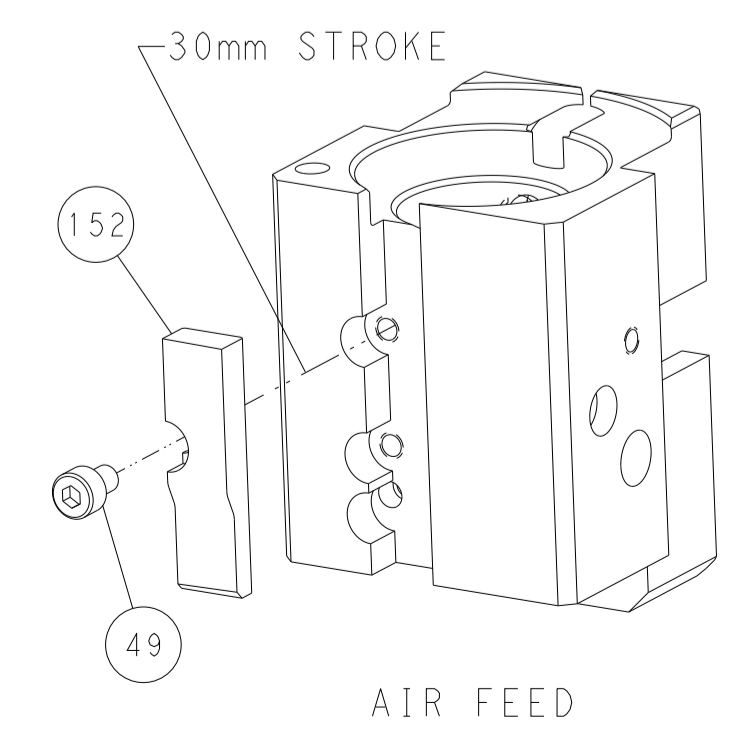

PACIFIC VERSION
 Shown on sheets 3 of 4 & 4 of 4
 (Atlantic version shown on sheets 1 of 4 & 2 of 4)

DIMENSIONS:		TOLERANCES UNLESS OTHERWISE SPECIFIED:		DWN BOB HIGMAN 15APR2014 CHK G. BAILEY 15APR2014 APVD G. BAILEY 15APR2014 PRODUCT SPEC APPLICATION SPEC WEIGHT CUSTOMER ACCESSIBLE PRODUCTION DRAWING		NAME Ocean End Feed Applicator SIZE A1 CAGE CODE 00779 DRAWING NO. C=2150428 SCALE 1:1 SHEET 4 OF 4 REV C		STE TE Connectivity Harrisburg, PA 17105-3608		
mm	0 PLC ±	1 PLC ±	2 PLC ±	3 PLC ±	4 PLC ±	ANGLES ±	FINISH ±	RESTRICTED TO		