

THIS DRAWING IS UNPUBLISHED. RELEASED FOR PUBLICATION
 © COPYRIGHT - TE Connectivity Ltd. ALL RIGHTS RESERVED.

REVISIONS					
P	LTR	DESCRIPTION	DATE	DWN	APVD
D		REV, RDRW, & SM PKG PER 0720-0061-93	4-16-93	-	1/8 DAP
D1		REVISED PER ECO-17-008808	01MAR2018	RS	DR

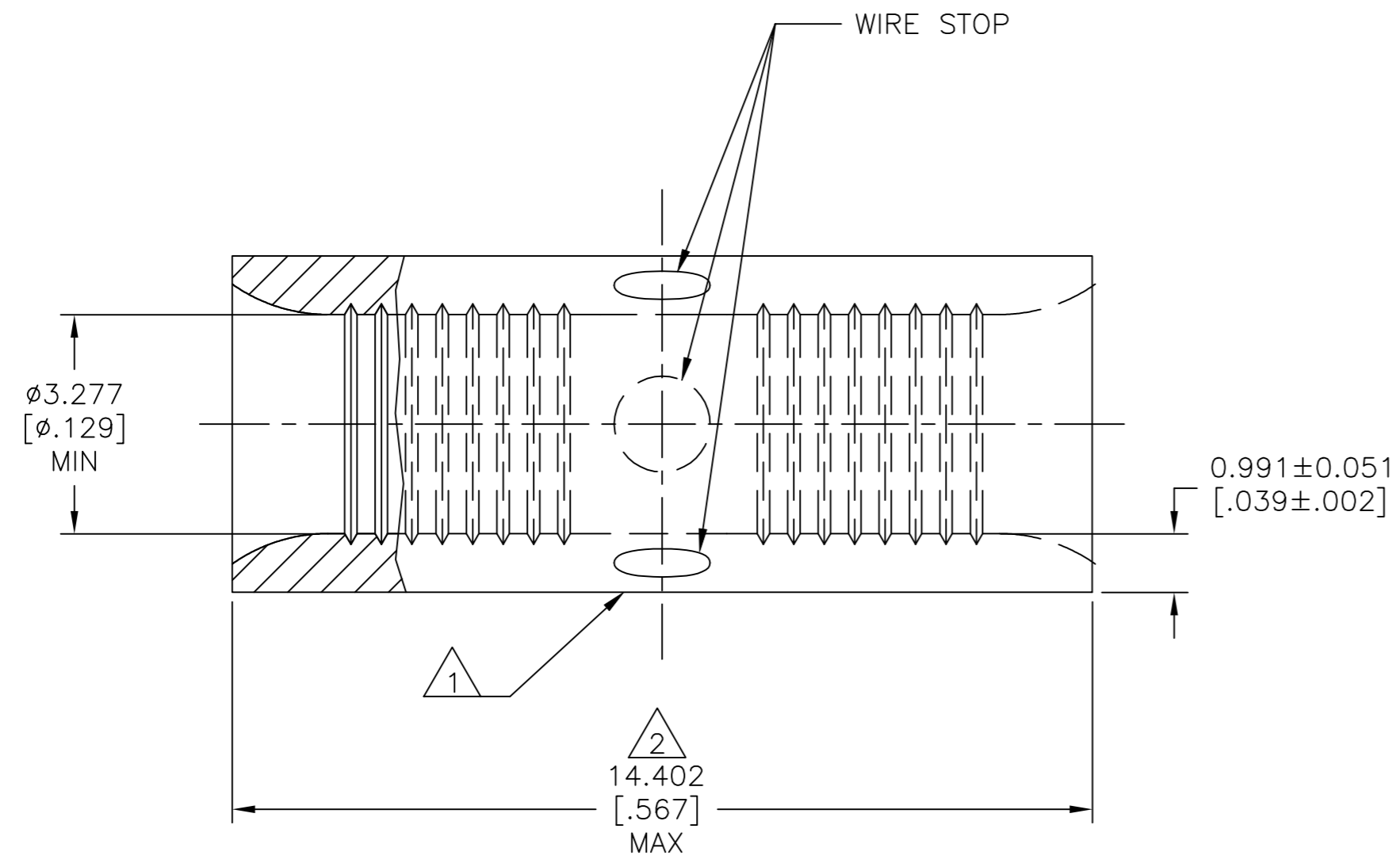
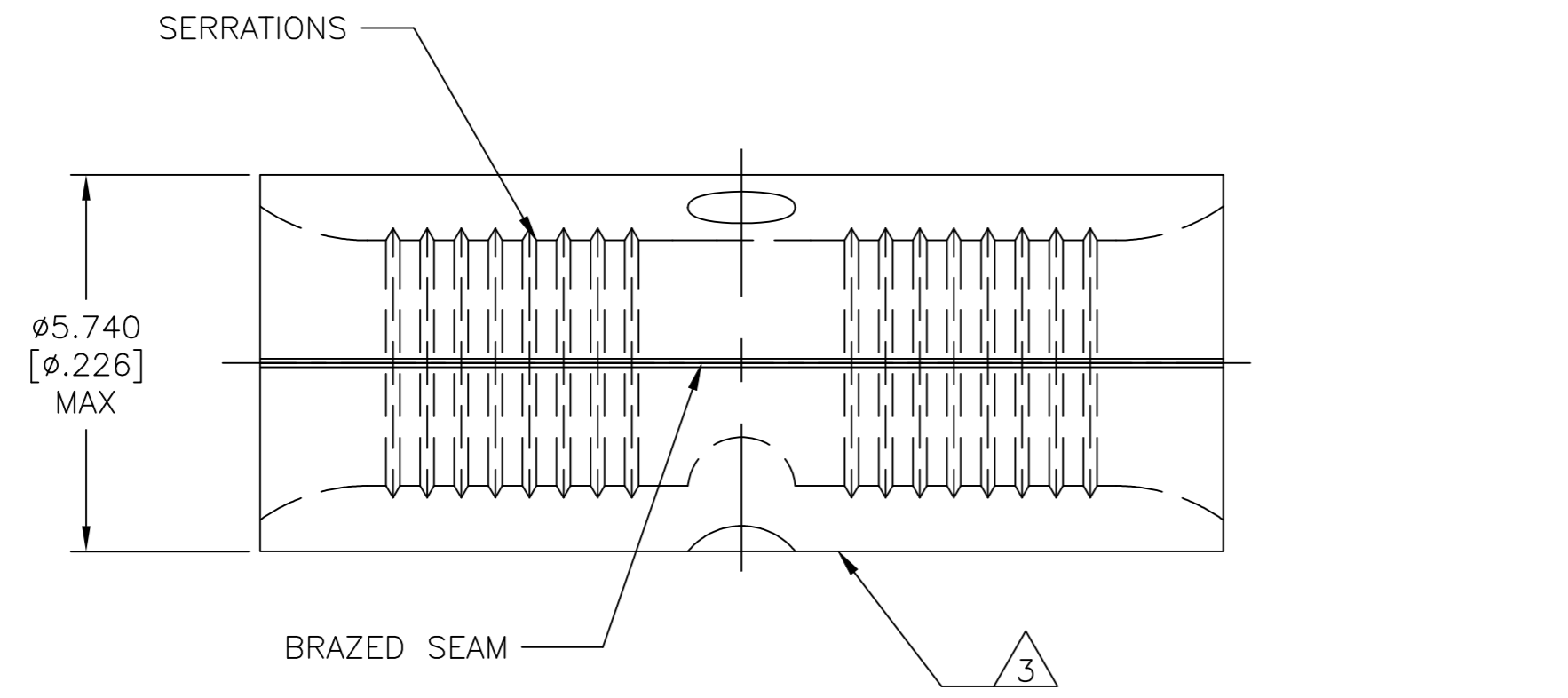

AMP WIRE RANGE	E13288 Listed
12-10 AWG SOLID OR STRANDED	NOT APPLICABLE
LR7189 Certified	MILITARY P/N AND CLASS
NOT APPLICABLE	NOT APPLICABLE

- 1 STAMP AMP 12-10 APPROX AS SHOWN
- 2 MAXIMUM LENGTH DOES NOT INCLUDE MANUFACTURING TABS
- 3 WIRE BARREL COLOR CODED ORANGE TO DENOTE NICKEL MATERIAL

500	LOOSE PIECE	323696
QUANTITY	PACKAGE TYPE	PART NO

AMP INCORPORATED CUSTOMER SERVICE SYSTEMS			THIS DRAWING IS A CONTROLLED DOCUMENT.		DWN TA BRINKMAN 4-16-93	TE Connectivity Ltd. NAME SPLICE, BUTT, STANDARD, HIGH TEMPERATURE, STRATO-THERM, 12-10 AWG
FOR ADDITIONAL PRODUCT INFORMATION OR COPIES OF DRAWINGS AND TECHNICAL DOCUMENTS	PRODUCT INFORMATION CENTER 1-800-522-6752	MAX RECOMMENDED OPERATING TEMPERATURE: 649°C [1200°F] MAX	DIMENSIONS: mm [INCHES]	TOLERANCES UNLESS OTHERWISE SPECIFIED:	CHK DA PATTERSON 4-16-93	
FOR APPLICATION	TOOLING ASSISTANCE CENTER 1-800-722-1111	VOLTAGE RATING: NOT APPLICABLE		0 PLC ± - 1 PLC ± - 2 PLC ± - 3 PLC ± 0.127[.005] 4 PLC ± - ANGLES ± -	APVD DE MILLER 4-16-93	
TOOLING INFORMATION	1-800-722-1111	WIRE CROSS SECTIONAL AREA RANGE, 2.62-6.64mm ² [5,180-13,100] CIR MILS SOLID OR STRANDED	MATERIAL NICKEL PER ASTM B-162 ANNEALED	FINISH -	PRODUCT SPEC -	
FOR ORDER ENTRY	1-800-526-5142				APPLICATION SPEC -	SIZE A2
					WEIGHT	CAGE CODE 00779
					CUSTOMER DRAWING	DRAWING NO C=323696
					SCALE 10:1	SHEET 1 of 1
					REV D1	RESTRICTED TO -