

Altivar 212

Variable speed drives
for asynchronous motors

Metasys N2 communication manual

01/2011



The information provided in this documentation contains general descriptions and/or technical characteristics of the performance of the products contained herein. This documentation is not intended as a substitute for and is not to be used for determining suitability or reliability of these products for specific user applications. It is the duty of any such user or integrator to perform the appropriate and complete risk analysis, evaluation and testing of the products with respect to the relevant specific application or use thereof. Neither Schneider Electric nor any of its affiliates or subsidiaries shall be responsible or liable for misuse of the information contained herein. If you have any suggestions for improvements or amendments or have found errors in this publication, please notify us.

No part of this document may be reproduced in any form or by any means, electronic or mechanical, including photocopying, without express written permission of Schneider Electric.

All pertinent state, regional, and local safety regulations must be observed when installing and using this product. For reasons of safety and to help ensure compliance with documented system data, only the manufacturer should perform repairs to components.

When devices are used for applications with technical safety requirements, the relevant instructions must be followed.

Failure to use Schneider Electric software or approved software with our hardware products may result in injury, harm, or improper operating results.

Failure to observe this information can result in injury or equipment damage.

© 2011 Schneider Electric. All rights reserved.

Table of Contents

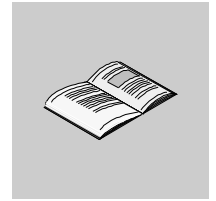

	Safety Information	5
	About the Book	6
Chapter 1	Introduction	9
Chapter 2	Hardware	11
	Hardware description	12
	Use of open Style Connector	12
	Description of terminals	13
Chapter 3	Connecting to the bus	15
	Cable routing practices	16
	Card connector pinout	17
Chapter 4	Configuration	19
	Communication parameters	20
	Configuration of the control	23
Chapter 5	Network objects	29
	List of type supported by ATV212	30
	Additional functions	32
Chapter 6	Diagnostics	33
	Communication detected faults	34
	LED indicators	35
	Detected fault possible causes and remedies	36

Safety Information

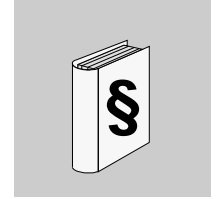

Important Information

NOTICE

Read these instructions carefully, and look at the equipment to become familiar with the device before trying to install, operate, or maintain it. The following special messages may appear throughout this documentation or on the equipment to warn of potential hazards or to call attention to information that clarifies or simplifies a procedure.



The addition of this symbol to a Danger or Warning safety label indicates that an electrical hazard exists, which will result in personal injury if the instructions are not followed.



This is the safety alert symbol. It is used to alert you to potential personal injury hazards. Obey all safety message that follow this symbol to avoid possible injury or death.

DANGER

DANGER indicates an imminently hazardous situation, which, if not avoided, **will result** in death or serious injury.

WARNING

WARNING indicates a potentially hazardous situation, which, if not avoided, **can result** in death, serious injury or equipment damage.

CAUTION

CAUTION indicates a potentially hazardous situation, which, if not avoided, **can result** in injury or equipment damage.

CAUTION

CAUTION, used without the safety alert symbol, indicates a potentially hazardous situation which, if not avoided, **can result** in equipment damage.

PLEASE NOTE

The word “drive” as used in this manual refers to the controller portion of the adjustable speed drive as defined by NEC.

Electrical equipment should be installed, operated, serviced, and maintained only by qualified personnel. No responsibility is assumed by Schneider Electric for any consequences arising out of the use of this material.

About the Book

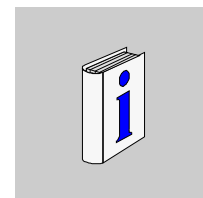

At a Glance

Document Scope

The purpose of this document is to show you how to configure the Altivar 212 to use Metasys® for monitoring and control.

NOTE: Read and understand this document and all related documents (see below) before installing, operating, or maintaining your ATV212.

Validity Note

This documentation is valid for the Altivar 212 Metasys® fieldbus.

Related Documents

Title of Documentation	Reference Number
ATV212 Quick Start	S1A53825
ATV212 Installation manual	S1A53832
ATV212 Programming manual	S1A53838
ATV212 Modbus manual	S1A53844
ATV212 LonWorks manual	S1A53848
ATV212 Apogée FLN P1 manual	S1A53847
ATV212 BACnet manual	S1A53845
ATV212 other option manuals: see www.schneider-electric.com	

You can download the latest versions of these technical publications and other technical information from our website at www.schneider-electric.com.

Product Related Information

⚠ DANGER

UNINTENDED EQUIPMENT OPERATION

- Read and understand this manual before installing or operating the Altivar 212 drive.
- Any changes made to the parameter settings must be performed by qualified personnel.

Failure to follow these instructions will result in death or serious injury.

Before you begin

⚠️⚠️ DANGER

HAZARD OF ELECTRIC SHOCK, EXPLOSION OR ARC FLASH

- Read and understand this manual before installing or operating the drive. Installation, adjustment, repair, and maintenance must be performed by qualified personnel.
- The user is responsible for compliance with all international and national electrical code requirements with respect to grounding of all equipment.
- Many parts of this drive, including the printed circuit boards, operate at the line voltage. **DO NOT TOUCH.** Use only electrically insulated tools.
- **DO NOT** touch unshielded components or terminal strip screw connections with voltage present.
- **DO NOT** short across terminals PA/+ and PC/- or across the DC bus capacitors.
- Before servicing the drive:
 - Disconnect all power, including external control power that may be present.
 - Place a “DO NOT TURN ON” label on all power disconnects.
 - Lock all power disconnects in the open position.
 - **WAIT 15 MINUTES** to allow the DC bus capacitors to discharge.
 - Measure the voltage of the DC bus between the PA/+ and PC/- terminals to ensure that the voltage is less than 42 Vdc.
 - If the DC bus capacitors do not discharge completely, contact your local Schneider Electric representative. Do not repair or operate the drive
- Install and close all covers before applying power or starting and stopping the drive.

Failure to follow these instructions will result in death or serious injury.

⚠️ WARNING

DAMAGE DRIVE EQUIPMENT

Do not operate or install any drive or drive accessory that appears damaged.

Failure to follow these instructions can result in death, serious injury, or equipment damage.

⚠️ WARNING

LOSS OF CONTROL

- The designer of any control scheme must consider the potential failure modes of control paths and, for certain critical control functions, provide a means to achieve a safe state during and after a path failure. Examples of critical control functions are emergency stop and overtravel stop.
- Separate or redundant control paths must be provided for critical control functions.
- System control paths may include communication links. Consideration must be given to the implications of unanticipated transmission delays or failures of the link (1).

Failure to follow these instructions can result in death, serious injury, or equipment damage.

For additional information, refer to NEMA ICS 1.1 (latest edition), “Safety Guidelines for the Application, Installation, and Maintenance of Solid State Control” and to NEMA ICS 7.1 (latest edition), “Safety Standards for Construction and Guide for Selection, Installation and Operation of Adjustable-Speed Drive Systems.”

Introduction

1

Data exchanges give access to the Altivar 212 functions:

- Control (start, stop, reset, setpoint),
- Monitoring (status, current, voltage, thermal state...),
- Diagnostics (alarms).

The integrated display terminal and the graphic display option can be used to access numerous functions for communication configuration and diagnostics.

Hardware



2

What's in this Chapter?

This chapter contains the following topics:

Topic	Page
Hardware description	12
Use of open Style Connector	12
Description of terminals	13

Hardware description

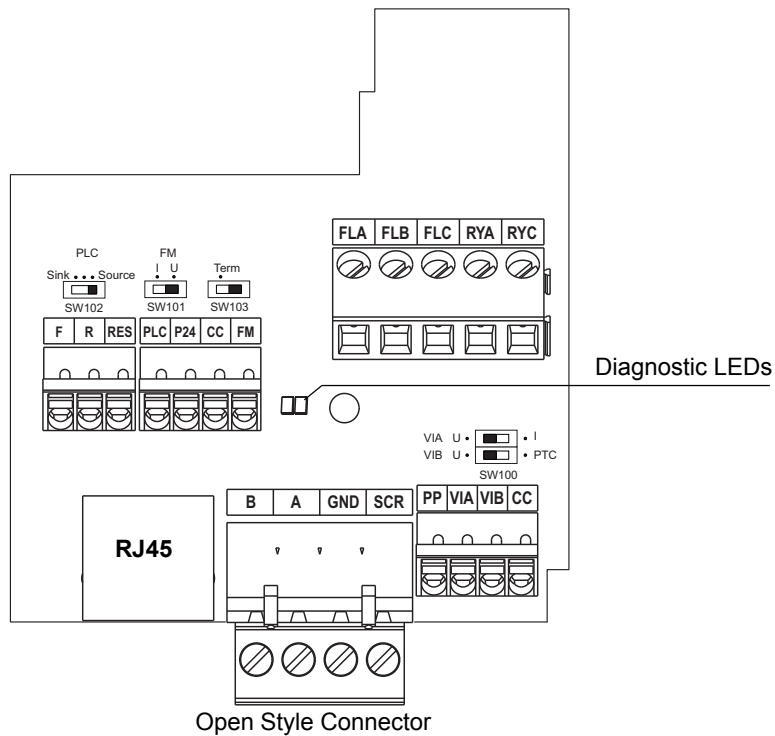

Use of open Style Connector

Use the open style connector to connect the drive to Metasys N2 fieldbus. Full connection details are given in the Connecting to the bus section page [15](#).

⚠ DANGER

UNINTENDED EQUIPMENT OPERATION

- Modify only the setting of the switches when the product is switched off.
- Do not change the setting of the SW102 unless your system is wired for SINK logic.

Failure to follow these instructions will result in death or serious injury.

⚠ CAUTION

RISK OF BODY INJURY

Use a screwdriver to change the position of the switches.

Failure to follow these instructions will result in death or serious injury.

Description of terminals

Terminal symbol	Function	Electrical specifications	Internal circuits
F	Multifunctional programmable logic input. It has forward rotation function in default setting. ON: forward rotation drive OFF: slowdown and stop	Input for voltage-free contact 24 Vdc, 5 mA or less. SINK/SOURCE can be selected with SW102.	
R	Multifunctional programmable logic input. It has Preset speed command input 1 in default setting.		
RES	Multifunctional programmable logic input. It has Fault Reset in default setting		
PP	Voltage supply for reference potentiometer.	Voltage: 10 Vdc Max current: 10 mA Protected against short circuits.	
VIA	Switch-configurable voltage or current analog input using SW100. It has speed setpoint function in the default setting. (0 to 50 Hz frequency with 0 to 10 Vdc in voltage or with 0 to 20 mA in current input). In addition, This analog input is also configurable as a logic input.	Voltage: 10 Vdc Internal impedance: 30 kΩ Current: 0 - 20 mA	
VIB	Multifunction programmable analog input. It has speed setpoint function in the default setting (0 to 50 Hz frequency with 0 to 10 Vdc input). In addition, this terminal can be used as PTC (2) input by setting switch SW100 and the parameters [Mot PTC selection] F 5 4 5 and [PTC resistor value] F 5 4 6.	Voltage: 10 Vdc Internal impedance: 30 kΩ	
CC	Control circuit equipotential terminal	-	
PLC	This terminal is only active when the switch (SINK-SOURCE) is on PLC position. It allow to manage external sink or source with static outputs. PLC shall be connected to 0V (CC terminal) or +24V according to the type of outputs	Max. voltage: 50 Vdc	
P24	24 Vdc power supply output	Voltage: 24 Vdc, 50 mA	
FM	Switch-configurable voltage or current analog output using SW101.	Voltage analog output: 0...10 Vdc Minimum load impedance: 470 Ω Current analog output: 0...20 mA Maximum load impedance: 550 Ω	
FLA FLB FLC RYA RYC	Multifunctional programmable relay contact outputs. Default setting is set to detect the activation of the drive protection function. Contact across FLA-FLC is closed and FLB-FLC is open during normal operation. RYA -RYC is open.	Voltage: 30 Vdc, 0.5 A 250 Vac, 1A (cos φ = 1) Voltage: 250 Vac, 0.5A (cos φ = 0.4)	

(1) Voltage conversion

(2) PTC (Positive Temperature Coefficient): Resettable thermal fuse resistor for over current protection.

Terminal symbol	Function	Electrical specifications	Internal circuits
B A GND	BACnet open style connector	RS485 transmission data, reception data.	
SCR	BACnet communication shield terminal. This terminal is not connected to other circuits in the board. Ground this terminal in a location separated from the ground of the power line.		

Connecting to the bus



3

What's in this Chapter?

This chapter contains the following topics:

Topic	Page
Cable routing practices	16
Card connector pinout	17

Cable routing practices

Termination resistor

Note: The ATV212 drive includes a line termination as standard. Set switch 103 to Term to connect the internal 120 Ω termination resistor.

Install a line terminator at both ends of the line.

⚠ DANGER

UNINTENDED EQUIPMENT OPERATION DUE TO IMPROPER WIRING PRACTICES

- Follow the wiring practices described in this document in addition to those already required by the National Electrical Code and local electrical codes.
- Check the power connections before energizing the drive.
- If replacing another drive, verify that all wiring connections to the ATV212 drive comply with all wiring instructions in this manual.

Failure to follow these instructions will result in death or serious injury.

When wiring Altivar 212 drives to a Metasys N2 network, observe the following guidelines:

- Avoid areas of high temperature, moisture, vibration, or other mechanical stress.
- Secure the cable where necessary to prevent its weight and the weight of other cables from pulling or twisting the cable.
- Use cable ducts, raceways, or other structures to protect the cable. Route the power cables apart from these structures.
- Avoid sources of electrical interference that can induce noise into the cable. Use the maximum practicable separation from such sources.

When planning cable routing within a building, follow these guidelines:

- Maintain a minimum separation of 1 m (3.3 ft) from the following equipment:
 - air conditioners and large blowers,
 - elevators and escalators,
 - radios and televisions,
 - intercom and security systems,
 - fluorescent, incandescent, and neon lighting fixtures.
- Maintain a minimum separation of 3 m (9.8 ft) from the following equipment:
 - line and motor power wiring,
 - transformers,
 - generators,
 - alternators.

When wiring in electrical equipment rooms or large electrical equipment line-ups, observe the following guidelines for cable segregation and separation of circuits:

- Use metallic conduit for drive wiring. Route control, network and power wiring in separate conduits.
- Separate non-metallic conduits or cable trays carrying power wiring from metallic conduit carrying low-level control network wiring by at least 305 mm (12 in.).
- Separate metallic conduits carrying power wiring or low-level control network wiring by at least 76 mm (3 in.).
- Whenever power and control wiring cross, the metallic conduits and non-metallic conduits or trays will cross at right angles.
- If necessary, use filters to attenuate conducted emissions from the drive to the line to help prevent interference with telecommunication, radio, and sensitive electronic equipment. Consult the Altivar catalog for selection and application of these filters.

Card connector pinout

Observe the following recommendations for wiring the terminals:

- Connections: 2-wire differential, common, and shield
- Maximum devices per segment: 32
- Maximum cable length: 1200 m (3637 ft)
- Line terminators: install line terminators at both ends of the line

Refer to the following figure for the pinout of the network terminal. When wiring the terminal:

1. Strip the cable sheath back approximately 10 mm (0.40 in.).
2. Use a flat blade screwdriver with a 0.6 mm (0.02 in.) thick and 3.5 mm (0.14 in.) wide blade for making the connections to the terminals.
3. Use a torque wrench to tighten the terminals to 0.5 to 0.6 N•m (4.4 to 5.3 lb-in.).

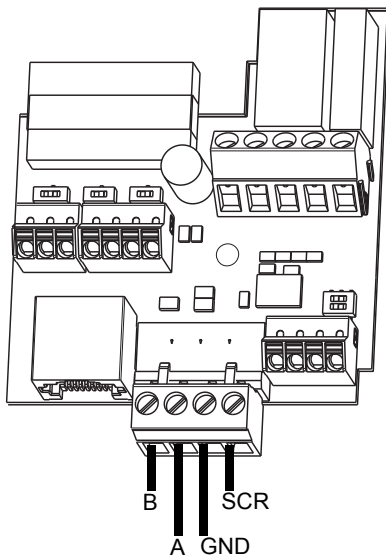

Contact	Signal
B	+
A	-
GND	Common
SCR	Shield

Configuration



4

What's in this Chapter?

This chapter contains the following topics:

Topic	Page
Communication parameters	20
Configuration of the control	23

Communication parameters

Access to the parameters

Parameters	Location
[Command mode sel] (C P O d) [Frequency mode sel] (F P O d)	[PROGRAMMING MENU] Programming mode
[Remote spd ref 2] (F 2 O 7) [Mot. poles (comm.)] (F B 5 6)	[EXTENDED MENU] F - - - submenu of [PROGRAMMING MENU] Programming mode.
Other parameters	[COMMUNICATION MENU] C O P submenu of [PROGRAMMING MENU] Programming mode.

Configuration

Configure the following parameters. Select Metasys N2 communication protocol by setting [Network protocol] F B 2 9 to 2 [Metasys N2].

The baud rate and parity are fixed: 9600 bit/s, 8 bit, no parity, 1 stop.

⚠ DANGER

UNINTENDED EQUIPMENT OPERATION

Refer to «Serial communication parameters» in the Altivar 212 Programming manual, for more information on how to set these serial communication parameters.

Failure to follow these instructions will result in death or serious injury.

Parameters	Possible values	Default value
[Command mode sel] (C P O d) Remote mode start/stop control source	0 [Logic inputs]: Control terminal logic input 1 [HMI]: Graphic display terminal 2 [Communication]: Serial communication	0
[Frequency mode sel] (F P O d) Remote mode primary speed reference source	1 [Ref source VIA]: VIA 2 [Ref source VIB]: VIB 3 [HMI reference]: Graphic display terminal 4 [Serial com ref]: Serial communication 5 [+/- Speed]: +/- speed from external contact	1
[Com channel choice] (F B O 7) Communication channel choice	0 [RJ45]: Command Modbus via RJ45 port 1 [Open style]: Command via open style port	1
[Network protocol] (F B 2 9) Communication protocol	1 [Mdb RTU]: Modbus® RTU protocol 2 [Metasys N2]: Metasys® N2 protocol 3 [Apogee P1]: APOGEE® FLN P1 protocol 4 [BACnet]: BACnet protocol 5 [Lonworks]: Lonworks protocol	1
[Com. fault setting] (F B 5 1) Drive behavior after a communication interruption	0 [Ramp stop (F/Cmod)]: Communication release. Drive ramps to a stop. Serial control is relinquished to sources defined by [Command mode sel] (C P O d) and [Frequency mode sel] (F P O d) 1 [No active]: No action. Last commanded operation continues. 2 [Ramp stop] : Deceleration stop. Drive ramps to a stop. Serial control is maintained. 3 [Freewheel]: Drive removes power from the motor which coasts to a stop. Serial control is maintained. 4 [Err5 or Err8]: Drive ramps to a stop. An Err 5 [Com RJ45 fault] or Err 8 [Network error fault] is displayed.	4

Parameters	Possible values	Default value
<p>[Mot. poles (comm.)] (<i>F B 5 6</i>)</p> <p>Set the motor pole number. This parameter is for calculation of min-1 unit motor speed of Metasys N2 data</p>	<p><i>1</i> [2 poles] <i>5</i> [10 poles] <i>2</i> [4 poles] <i>6</i> [12 poles] <i>3</i> [6 poles] <i>7</i> [14 poles] <i>4</i> [8 poles] <i>8</i> [16 poles]</p>	<i>2</i>
<p>[Network address] (<i>F B 9 0</i>)</p> <p>Address</p>	Setting range: 0 to 127	<i>0</i>
<p>[Network time out] (<i>F B 9 2</i>)</p> <p>Network communication detected error trip time</p>	Setting range: 20 to 600 (2 to 60 s)	<i>1 0 0</i>
<p>[FA15] (<i>F R 1 5</i>)</p> <p>Communication counter</p> <p>Displays the total number of frames received by the drive since the last power ON. These values can be monitored by panel (monitor mode).</p>	Range: 0 to 999	<i>0</i>
<p>[FA16] (<i>F R 1 6</i>)</p> <p>Normal communication counter</p> <p>Displays the total number of bad frames received by the drive since the last power ON. These values can be monitored by panel (monitor mode).</p>	Range: 0 to 999	<i>0</i>

Command and speed reference channels

C N O d and **F N O d** drive parameters are used to set the channel for command and speed reference (first source).

F 2 0 7 drive parameter is used to set the second source of speed reference. Switching between source 1 and 2 is done by **F 2 0 0** parameter or logical input when set to this function.

F B 0 7 sets the communication channel (RJ45 or Open Style network connector)

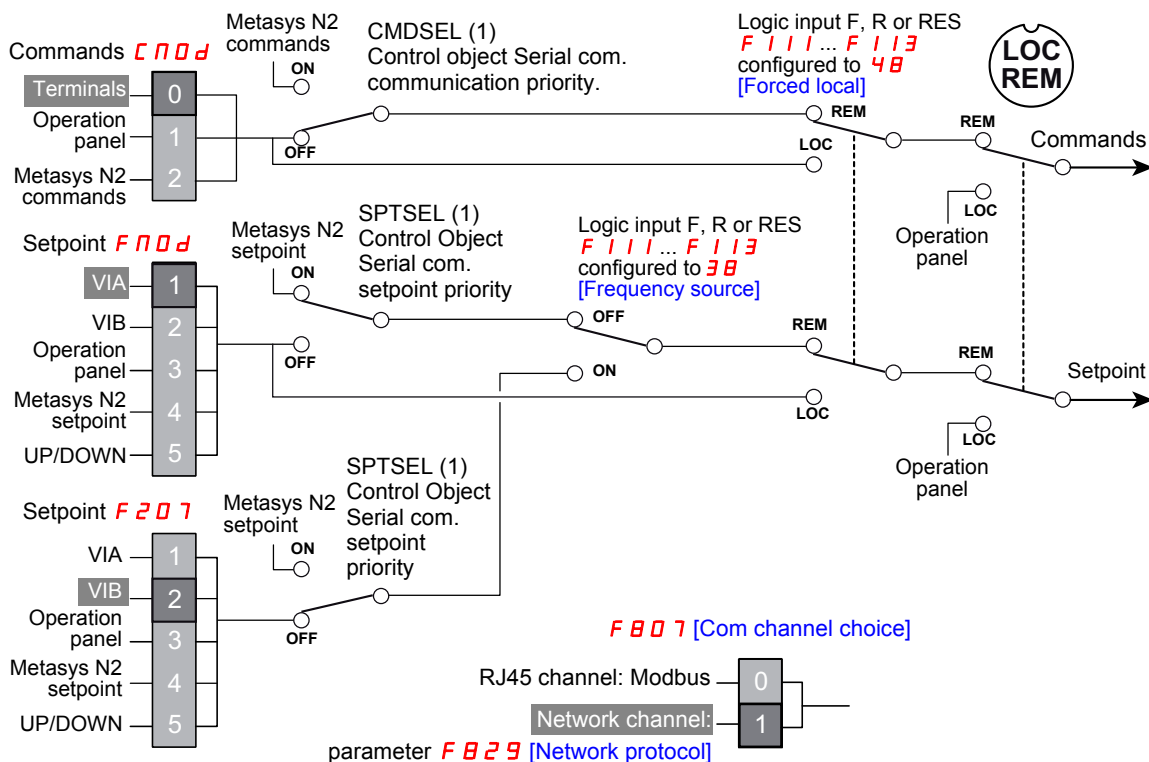

(1) For more information, please refer to Control objects page 30.

Configuration of the control

The drive can be controlled (command and speed reference) by the Metasys N2 network as well as by many other canals:

- I/O,
- Terminal (Local terminal, Graphic Keypad),
- RJ45 communication (Modbus).

The following figure shows the configuration for the command canal (Cmd SetPoint) and speed reference canal (Speed SetPoint)

The ATV212 can receive commands and speed setpoint from the Metasys N2 network or from the terminals (F, R, RES, VIA, VIB).

The LOC/REM key of the drive HMI is available to switch the control to the HMI.

Input F, R, RES can be configured to switch the control from the Metasys N2 to the terminals.

Control by the Metasys N2

Commands and setpoint come from the Metasys N2 network.

The LOC/REM key is active.

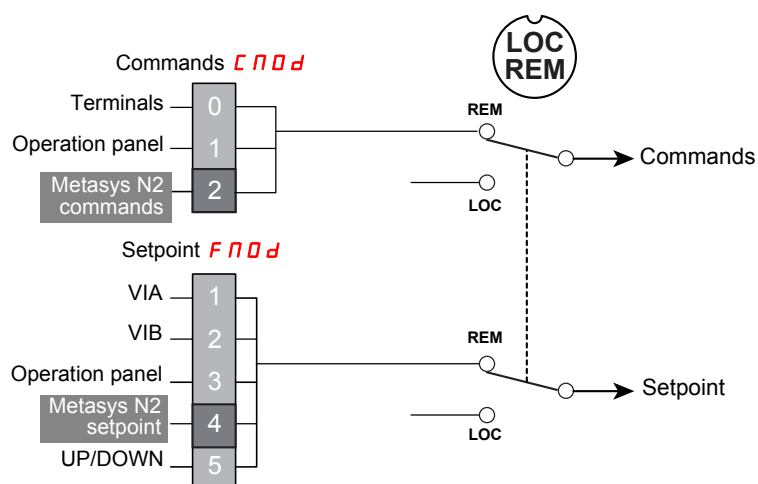

Control by terminals, monitoring by the Metasys N2 network

Commands and setpoint come from the terminals. The drive is monitored by the Metasys N2 network. The LOC/REM key is active.

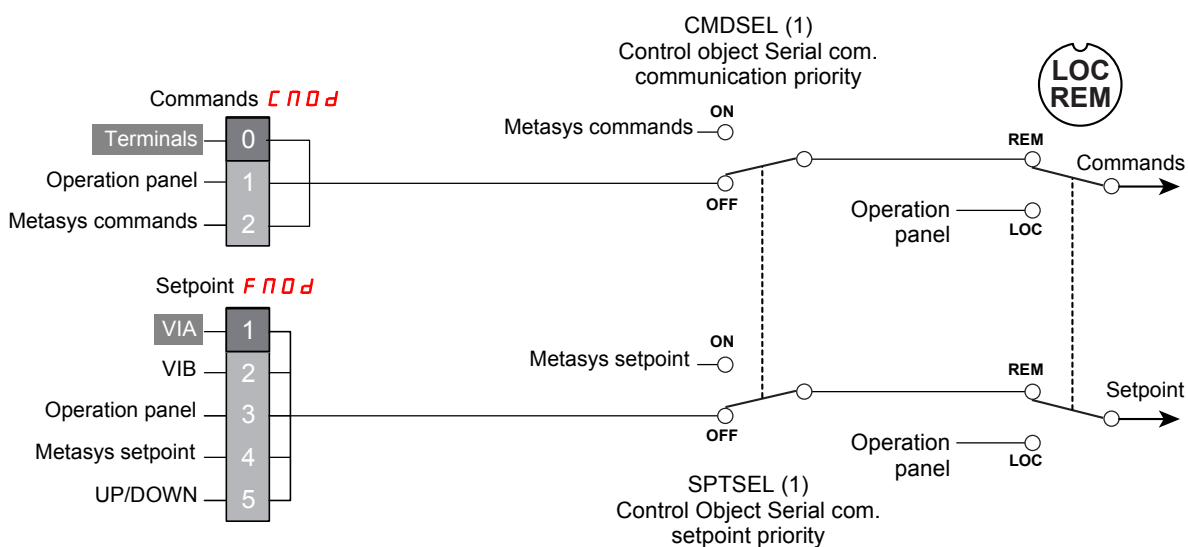

(1) For more information, please refer to Control objects page [30](#).

Access to the parameters

Parameters **CND** and **FND** are accessible in the [\[PROGRAMMING MENU\]](#) Programming mode.

Parameter description	Setting
[Command mode sel] (CND) Remote mode start/stop control source	0 [Logic inputs] : Control terminal logic input
[Frequency mode sel] (FND) Remote mode primary speed reference source	1 [Ref source VIA] : VIA

Control by the Metasys N2 network or the terminals switch by a logic input

The commands and the setpoint come from the Metasys N2 network if logic input R is OFF.
 The commands and the setpoint come from the terminals if logic input R is ON.
 The function **4B [Forced local]** is assigned to the logic input R.
 The LOC/REM key is valid.

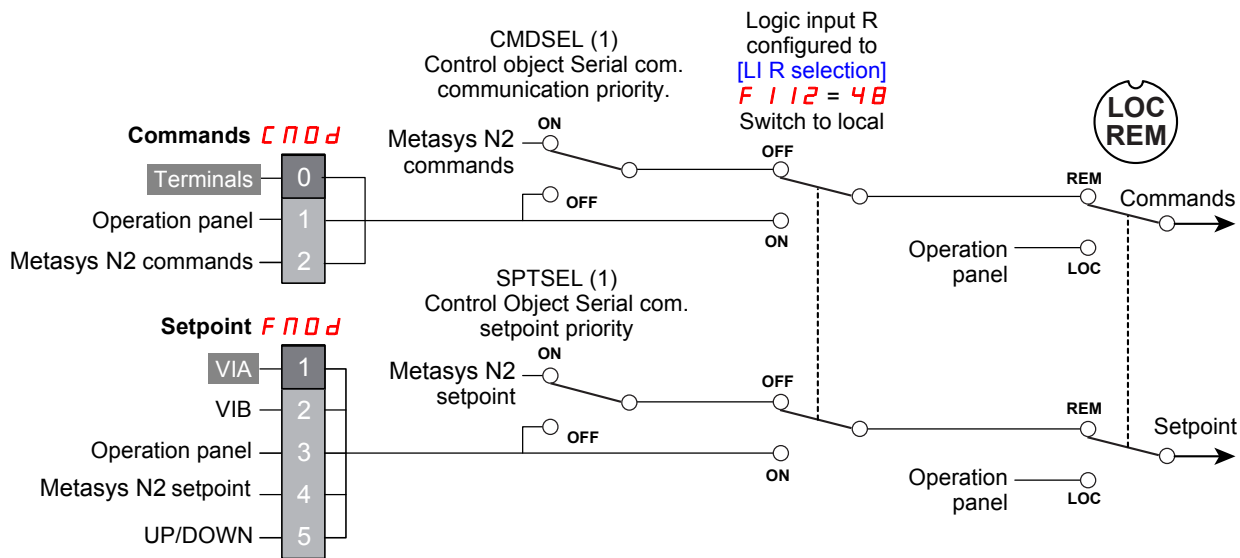

(1) For more information, please refer to Control objects page 30.

Access to the parameters

Parameters	Location
[Command mode sel] (C P O d) [Frequency mode sel] (F P O d)	[PROGRAMMING MENU] Programming mode
[Com channel choice] (F 1 1 2)	[I/O MENU] 1 0 submenu of [PROGRAMMING MENU] Programming mode.

Description

Parameter	Setting
[Command mode sel] (C P O d) Remote mode start/stop control source	0 [Logic inputs]: Control terminal logic input
[Frequency mode sel] (F P O d) Remote mode primary speed reference source	1 [Ref source VIA]: VIA
[LI R selection] (F 1 1 2) R Logic Input Function	4B [Forced local]: Forced switching from remote to local control

Command by the Metasys N2 network, setpoint by the Metasys N2 network or the terminals switched to by a logic input

The commands come from the Metasys N2 network.
 The setpoint comes from the Metasys N2 network if logic input R is OFF.
 The setpoint comes from the terminals if logic input R is ON.
 The function **3B** [Frequency source] is assigned to the logic input R.
 The LOC/REM key is valid.

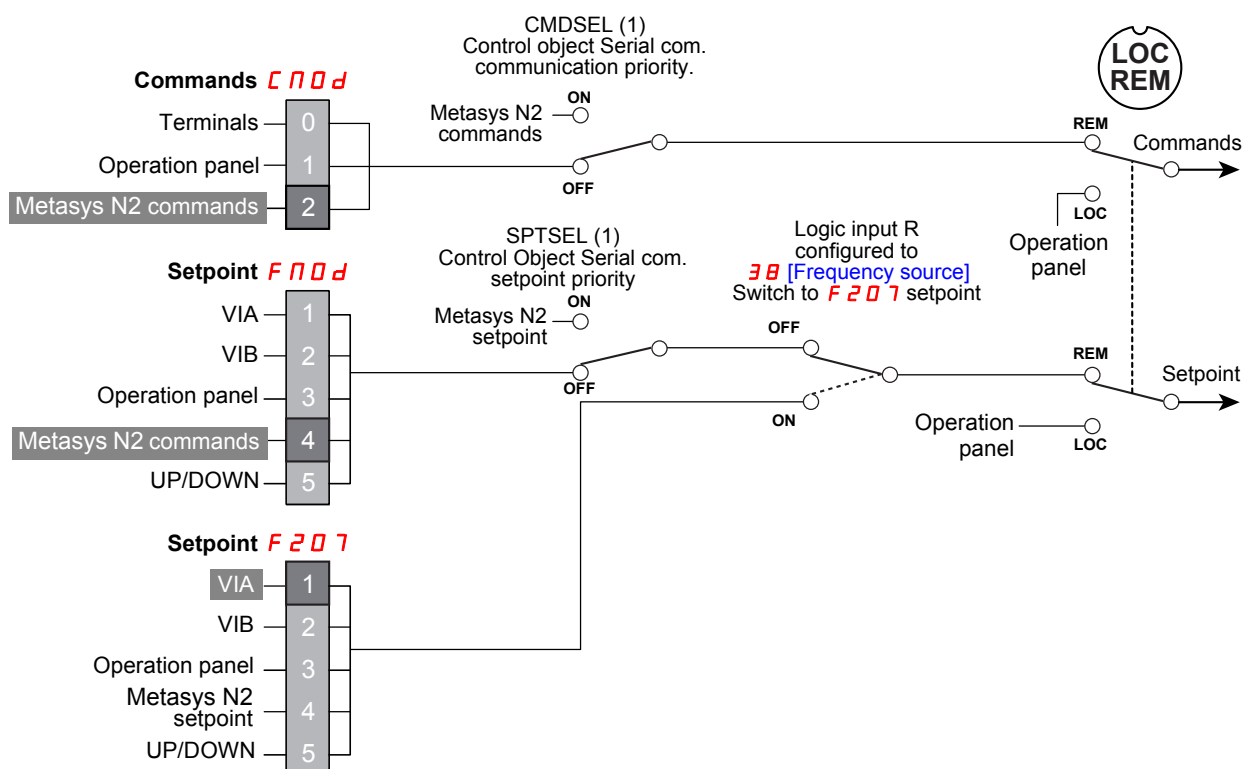

(1) For more information, please refer to Control objects page 30.

Access to the parameters

Parameters	Location
[Command mode sel] (C P O d) [Frequency mode sel] (F P O d)	[PROGRAMMING MENU] Programming mode
[Com channel choice] (F I I 2)	[I/O MENU] I O submenu of [PROGRAMMING MENU] Programming mode.
[Remote spd ref 2] (F 2 0 7)	[EXTENDED MENU] F - - - submenu of [PROGRAMMING MENU] Programming mode.
[Com channel choice] (F B 0 7)	[COMMUNICATION MENU] C O P submenu of [PROGRAMMING MENU] Programming mode.

Description

Parameter	Setting
[Command mode sel] (C P O d) Remote mode start/stop control source	2 [Communication]: Serial communication
[Frequency mode sel] (F P O d) Remote mode primary speed reference source	4 [Serial com ref]: Serial communication
[LI R selection] (F I I 2) R Logic Input Function	4B [Forced local]: Forced switching from remote to local control
[Remote spd ref 2] (F 2 0 7) Defines the remote mode secondary speed reference source	1 [VIA]: VIA
[Com channel choice] (F B 0 7) Communication channel choice	1 [Open style]: Command via open style port

Setpoint by the Metasys N2 network, switching commands to terminals by logic input

The commands and the setpoint come from the Metasys N2 network if logic input R is OFF.
 The commands come from the Metasys N2 network if logic input R is OFF.
 The commands come from the terminals if logic input R is ON.
 The setpoint comes from the Metasys N2 network.
 The function **4B [Forced local]** is assigned to the logic input R.
 The LOC/REM key is valid.

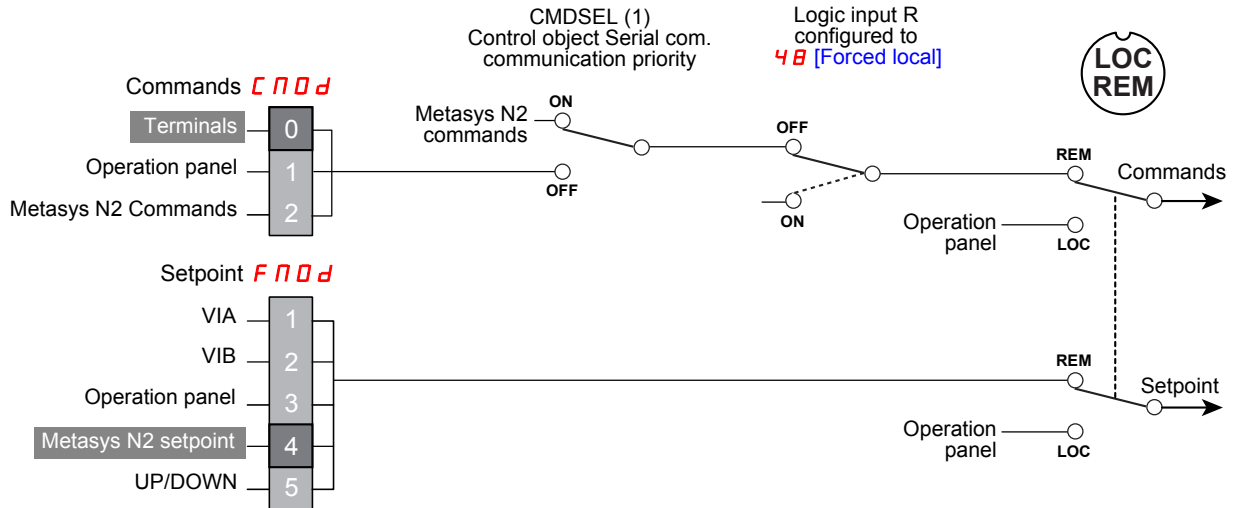

(1) For more information, please refer to Control objects page [30](#).

Access to the parameters

Parameters	Location
[Command mode sel] (C P D d) [Frequency mode sel] (F P D d)	[PROGRAMMING MENU] Programming mode
[Com channel choice] (F 1 1 2)	[I/O MENU] 1 0 submenu of [PROGRAMMING MENU] Programming mode.

Description.

Parameter	Setting
[Command mode sel] (C P D d) Remote mode start/stop control source	0 [Logic inputs]: Control terminal logic input
[Frequency mode sel] (F P D d) Remote mode primary speed reference source	4 [Serial com ref.]: Serial communication
[LI R selection] (F 1 1 2) R Logic Input Function	4B [Forced local] : Forced switching from remote to local control

Configuring the behaviour on communication interruption

Metasys N2 communication interruption

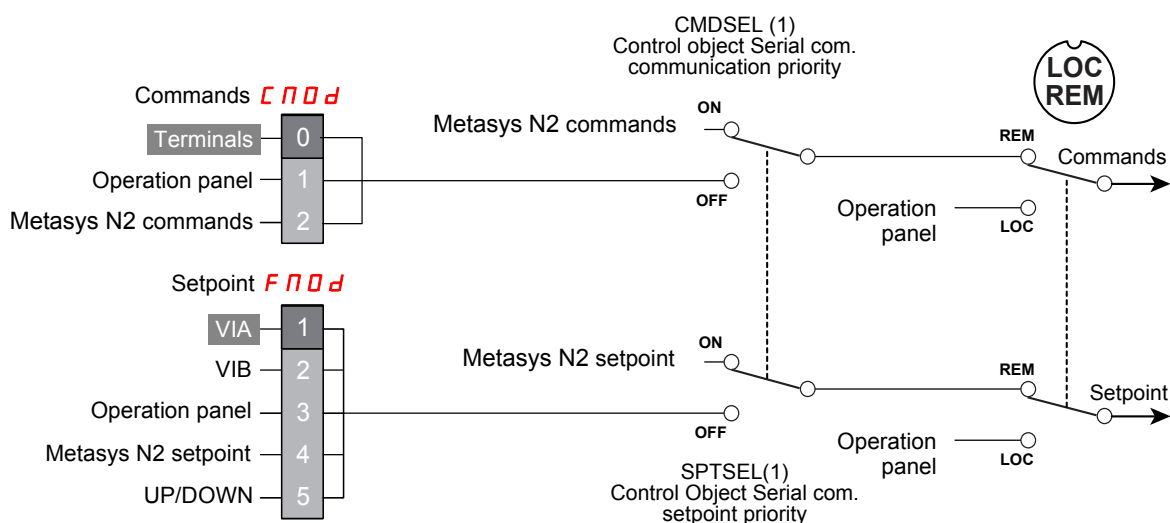

(1) For more information, please refer to Control objects page [30](#).

Access to the parameters

Parameters	Location
[Com. fault setting] (<i>FBS I</i>)	[COMMUNICATION MENU] <i>C D P</i> submenu of [PROGRAMMING MENU] Programming mode.
[Command mode sel] (<i>C P D d</i>) [Frequency mode sel] (<i>F P D d</i>)	[PROGRAMMING MENU] Programming mode

Configuration

If you want the drive to switch to terminal control in case of Metasys N2 communication interruption, configure:

Parameter	Setting
[Com. fault setting] (<i>FBS I</i>) Drive behavior after a communication interruption	<i>D</i> [Ramp stp (F/Cmod)]: Communication release
[Command mode sel] (<i>C P D d</i>) Remote mode start/stop control source	<i>D</i> [Logic inputs]: Control terminal logic input
[Frequency mode sel] (<i>F P D d</i>) Remote mode primary speed reference source	<i>I</i> [Ref source VIA]: VIA

Network objects



5

What's in this Chapter?

This chapter contains the following topics:

Topic	Page
List of type supported by ATV212	30
Additional functions	32

List of type supported by ATV212

- Drive I/O.
- Control.
- Parameters access.
- Identification.

Binary input points

Binary input point summary

The following table summarizes the binary input points supported:

ID	Point Names	Description
1	RO 1 ACT	Indicates status of relay R1
2	RO 2 ACT	Indicates status of relay RY
3	DI 1 ACT	Value of F
4	DI 2 ACT	Value of R
5	DI 3 ACT	Value of RES
6	RUNSTOP	Indicates the drive status
7	FWDREV	Indicates the motor rotation direction
8	FAULT	Indicates the drive's fault status
9	HAND/AUTO	Indicates if the drive is locally controlled or not.
10	MAINT REQ	Indicates alarms
11	DRIVE READY	The drive is ready and waits a start command.
12	AT SETPOINT	The drive has reached the target speed

Binary output points

Binary output point summary

The following table summarizes the binary output points supported:

ID	Point Names	Description
1	RO 1 CMD	R1 relay out accessible if assigned [FL Relay Function] <i>F 132</i> to <i>38</i> [Ser. data relay FL], <i>39</i> [Inv ser. dat rel. FL]
2	RO 2 CMD	R2 relay out accessible if assigned [RY Relay Function] <i>F 130</i> to <i>40</i> [Ser. data relay RY], <i>41</i> [Inv ser. dat rel. RY]
3	RUNSTOP CMD	Commands a drive start
4	FWDREV CMD	Commands a motor direction's change
5	FAULT REST	Clear the detected fault by resetting the drive
6	MBOX READ	Command to read parameter
7	MBOX WRITE	Command to write parameter
8	SP1PRESET	Preset speed operation frequencies 1
9	SP2PRESET	Preset speed operation frequencies 2
10	SP3PRESET	Preset speed operation frequencies 3
11	STPSEL	Frequency priority selection
12	CMDSEL	Command priority selection
13	DAMPER FBK	Damper feedback

Analog inputs

ID	Points Name	Description	Unit
1	OUTPUTSPEED	Output speed	rpm
2	OUTPUTFREQ	Output frequency	Hz
3	DCBUSVOLT	DC bus voltage	V
4	OUTPUT VOLT	Motor voltage	V
5	CURRENT	Motor current	A
6	TORQUE	Motor Torque	%
7	POWER	Motor Power	%
8	DRIVE TEMP	Drive Thermal State	%
9	KWH (R)	Energy counter	kWh
10	RUNTIME	Operating time	h
11	LASTFLT	Error code	-
12	PREVFLT1	Previous detected fault (occurred before LASTFLT)	-
13	PREVFLT2	Previous detected fault (occurred before PREVFLT1)	-
14	MBOXVALUEREAD	Parameter value	-
15	AI 1 ACT	Analog input 1 level	-
16	AO 1 ACT	Analog output 1 level	-
17	AI 2 ACT	Analog input value 2	-

Analog outputs

ID	Points Name	Description	Unit
1	INPUTREF1	Speed reference from Bus	% (1)
2	ACCEL1 TIME	Acceleration time	s
3	DECEL1 TIME	Deceleration time	s
4	MBOXPARAM	Parameter number	-
5	MBOXVALUEWRITE	Parameter value	-
6	AO1 COMMAND	Analog 1 output	-

(1) Range between 0 and 100.

Additional functions

Besides the services of “datasharing” the communication card provides the following functions.

Sync time command

This command is not supported by the VSD, the VSD will return a normal response : <A>,<CR>.

Status update request

The form and the version information of connected VSD are returned:

Example:

CHAR 1 Start of message : <A>

CHAR16 Model number : <ATV212XXXXXXXXXX>

CHAR4 Days in service :<0000>

CHAR4 Device status :<0108>

CHAR2 Checksum :<XX>

CHAR1 End of message:CR

Identify Device Type Command

This message is sent by the N2 controller, The VSD will start to respond to the request only if it had received this message.

This message requests the N2 device to respond with a unique code identifying which kind of N2 device it is.

Mailbox

By the use of indirect access, it is possible to read or write any of the internal parameters of the VSD.

This functionality is assured by these four objects:

MBOXPARAM, MBOXREAD, MBOXWRITE, MBOXVALUEREAD, MBOXVALUEWRITE.

- Reading

Write the logic address of the parameter to the present value property of the object MBOXPARAM.

Set present value property of the object MBOXREAD to “read”.

The current value of the parameter can be read in the present value property of MBOXVALUEREAD.

- Writing a parameter

Write the logic address of the parameter to the present value property of the object MBOXPARAM.

Write the new value in the present value property of the object MBOXDATA.

Set present value property of the object MBOXVALUEWRITE to “write”.

Note: MBOXREAD and MBOXWRITE automatically return back to inactive once command sent. Always return 0 when read.

Diagnostics



6

What's in this Chapter?

This chapter contains the following topics:

Topic	Page
Communication detected faults	34
The product has two LEDs, ERR red LED and COM green LED.LED indicators	35

Communication detected faults

General

The drive trips in *Err5* [Com RJ45 fault] or *ErrB* [Network error fault] if the communication was established and the card no longer receives messages from the network.

The response of the drive in the event of a BACnet communication interruption can be configured by the parameter [Com. fault setting] *FBSI*.

Behaviour on detected fault

Parameter description	Possible value	Default value
[Com. fault setting] (<i>FBSI</i>) Drive behavior after a communication interruption	<p>0 [Ramp stp (F/Cmod)]: Communication release. Drive ramps to a stop. Serial control is relinquished to sources defined by [Command mode sel] (<i>CMod</i>) and [Frequency mode sel] (<i>FMod</i>)</p> <p>1 [No active]: No action. Last commanded operation continues.</p> <p>2 [Ramp stop]: Deceleration stop. Drive ramps to a stop. Serial control is maintained.</p> <p>3 [Freewheel]: Drive removes power from the motor which coasts to a stop. Serial control is maintained.</p> <p>4 [Err5 or Err8]: Drive ramps to a stop. An <i>Err5</i> [Com RJ45 fault] or <i>ErrB</i> [Network error fault] is displayed.</p>	4

⚠ WARNING

LOSS OF CONTROL

If *FBSI* is set to **1**, communication control will be inhibited.

For safety reasons, inhibiting the communication interruption detection should be restricted to the debug phase or to special application.

Failure to follow these instructions can result in death, serious injury, or equipment damage.

⚠ WARNING

LOSS OF CONTROL

Know and understand the setting of parameter *FBSI*. This parameter controls the behavior of the drive in the event of a network communication loss. If the value of *FBSI* is **0**, **1**, **2**, or **3**, the drive will not trip on an *ErrB*.

Failure to follow these instructions can result in death, serious injury, or equipment damage.

LED indicators

Location

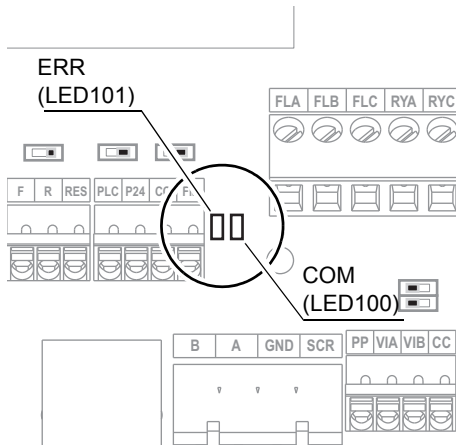

Description

The product has two LEDs, ERR red LED and COM green LED.

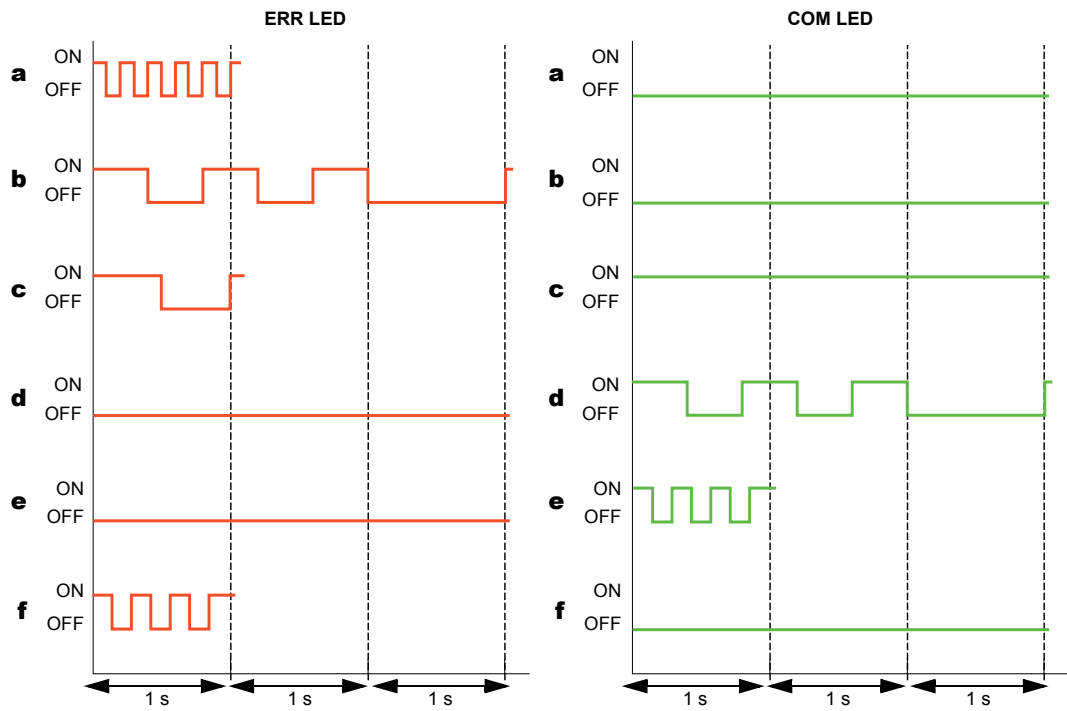

Functions

State	ERR: Red LED	COM: Green LED	Comment
a	Flashing 5 times in 1 second	OFF	Hardware detected fault
b	Flashing 3 times in 2 second, OFF for 1 second	OFF	Communication loss detected
c	ON 0.5 s, OFF 0.5 s	ON	Not applicable
d	OFF	Flashing 3 times in 2 second, OFF for 1 second	Not applicable
e	OFF	Flashing Intermittent	Valid message received for this node
f	Flashing Intermittent	OFF	Invalid message received (any node)

Detected fault possible causes and remedies

State	ERR: Red LED	COM: Green LED	Possible causes	Remedies
-	OFF	OFF	Drive not operating or turned off	Check the power supply.
a	Flashing 5 times per second	OFF	Internal communication error	<ul style="list-style-type: none"> • Check the environment (electromagnetic compatibility). • Check the card/drive connection. • Inspect or repair the drive.
b	Flashing, 3 times in 2 seconds, off for 1 second	OFF	ATV212 has not received valid message within time-out period.	<ul style="list-style-type: none"> • Check the environment (electromagnetic compatibility). • Check the wiring. • Check that the master is communicating within the time out period (= 10 s).
c	ON 0.5 s OFF 0.5 s	ON	Invalid configuration detected.	Check the internal communication parameters.
e			Green LED will flash whenever valid message is received.	NA
f	Intermittent flash	Intermittent flash	Red LED will flash whenever invalid message is received.	<ul style="list-style-type: none"> • Check the environment (electromagnetic compatibility). • Check the communication parameter configuration (protocol, speed, format). • Do not forget that the communication parameter configuration is only taken into account by the drive following a power break. • Check that the slave address is unique.

