

AN-1006

Power Diode Parameters and Characteristic Introduction

Content

- 1. Introduction.....2
 - 1.1 Purpose.....2
- 2. Absolute maximum ratings2
 - 2.1 V_{RRM} (repetitive peak reverse voltage)2
 - 2.2 $V_{R(RMS)}$ (reverse voltage, total rms value)2
 - 2.3 $I_{F(AV)}$ (forward current, mean value averaged over a full cycle)3
 - 2.4 I_{FSM} (forward current, surge peak).....4
 - 2.5 T_J (junction temperature)4
 - 2.6 T_{STG} (storage temperature)4
- 3. Static electrical characteristic.....5
 - 3.1 V_F (forward voltage)5
 - 3.2 I_R (reverse current)6
 - 3.3 T_{rr} (reverse recovery time)7
 - 3.3.1 Test condition B17
 - 3.3.2 Test condition D.....8
 - 3.3.3 T_{rr} relate to turn off loss.....8
 - 3.3.4 RRSF (reverse recovery softness factor)9
 - 3.4 C_j (junction capacitance).....10
 - 3.5 V_{FM} (peak forward voltage).....10
 - 3.6 R_{thjx}, Z_{thjx} (thermal resistance, thermal impedance)11
 - 3.6.1 R_{thjx} (thermal resistance).....11
 - 3.6.2 Z_{thjx} (thermal impedance).....13
 - 3.7 E_{AS} (Non-repetitive avalanche energy)14
- 4. Characteristics curves.....15
 - 4.1 Forward Current Derating Curve15
 - 4.2 Typical Forward Characteristics.....15
 - 4.3 Typical Reverse Characteristics16
 - 4.4 Typical Junction Capacitance.....16
 - 4.5 Typical Transient Thermal Impedance17
- Reference.....17

1. Introduction

1.1 Purpose

Diode includes power rectifier and small signal diode are common and popular semiconductor device in electric application. This application note is the description to explain of the diode parameters and characteristic. Some parameters will take datasheet specification as example for reference.

2. Absolute maximum ratings

2.1 V_{RRM} (repetitive peak reverse voltage)

V_{RRM} is the maximum sustainable repetitive value of the diode reverse voltage while applying reverse bias to diode. The value measured in reverse volt-ampere region of low incremental resistance at ambient temperature (25°C), wave form describe as (Figure 1). Note that diode needs to be operated equal or lower V_{RRM} in application. If the external breakdown voltage exceeds diode V_{RRM} , the diode might be burn out to broken.

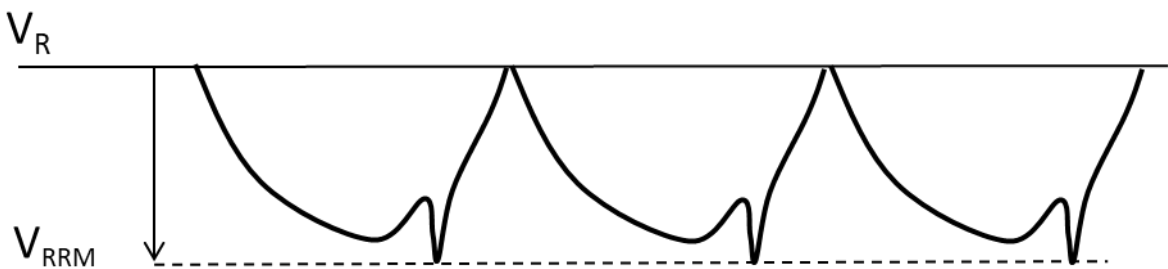

Figure 1 – Diode symbol of V_{RRM} (repetitive peak reverse voltage)

Take TSC datasheet “ES2BFSH – ES2JFSH” V_{RRM} spec as example:

ABSOLUTE MAXIMUM RATINGS (TA = 25°C unless otherwise noted)						
PARAMETER	SYMBOL	ES2BFSH	ES2DFSH	ES2GFSH	ES2JFSH	UNIT
Repetitive peak reverse voltage	V_{RRM}	100	200	400	600	V

2.2 $V_{R(RMS)}$ (reverse voltage, total rms value)

The root mean squared reverse voltage $V_{R(RMS)}$ is defined an AC sinusoidal waveform voltage V_{ac} supplies electrical power to a loading as an equivalent DC voltage V_{dc} supplies, the $V_{R(RMS)}$ is called the effective value. The relationship to V_{RRM} and calculation formula as below:

$$V_{RMS} = \sqrt{\frac{\int_0^T (V(t))^2 dt}{T}} = \sqrt{\frac{\int_0^T (V_{RRM} \sin \omega t)^2 d\omega t}{T}} = \sqrt{\frac{V_{RRM}^2}{\pi} \int_0^\pi \frac{1 - \cos 2\omega t}{2} d\omega t}$$

$$= \frac{V_{RRM}}{\sqrt{2}} = 0.707V_{RRM}$$

Country household supply voltage AC 230V or AC 110V belong to $V_{R(RMS)}$, we could calculate it according above relationship to get the peak voltage V_{RRM} :

$$V_{RRM} = \sqrt{2}V_{RMS}$$

Take TSC datasheet “ES2BFSH – ES2JFSH” $V_{R(RMS)}$ spec as example:

ABSOLUTE MAXIMUM RATINGS (TA = 25°C unless otherwise noted)						
PARAMETER	SYMBOL	ES2BFSH	ES2DFS	ES2GFSH	ES2JFSH	UNIT
Reverse voltage, total rms value	$V_{R(RMS)}$	70	140	280	420	V

2.3 $I_{F(AV)}$ (forward current, mean value averaged over a full cycle)

$I_{F(AV)}$ is the diode forward maximum sustainable average current when in specific temperature ($T_A=25^\circ C$). The $I_{F(AV)}$ magnitude degree can affect diode heat dissipation while apply forward bias in diode. Too big $I_{F(AV)}$ will offer big power go through diode and make device temperature heat up, if too big $I_{F(AV)}$ to exceed diode specification, it might make the diode junction temperature over to burn out. There is a relationship of thermal resistance R_{thjC} :

Apply average power:

$$P = V_F(@I_{F(peak)}) \times I_{F(AV)}$$

The average power present by temperature and thermal resistance T_J, T_C, R_{thjC} :

$$P = \frac{T_J - T_C}{R_{thjC}}$$

So $I_{F(AV)}$ relative to thermal resistance R_{thjC} formula can be represented:

$$V_F(@I_{F(peak)}) \times I_{F(AV)} = \frac{T_J - T_C}{R_{thjC}}$$

Take TSC datasheet “ES2BFSH – ES2JFSH” $I_{F(AV)}$ spec as example:

The I_F is DC current, $I_F = I_{F(AV)}$

ABSOLUTE MAXIMUM RATINGS (TA = 25°C unless otherwise noted)						
PARAMETER	SYMBOL	ES2BFSH	ES2DFS	ES2GFSH	ES2JFSH	UNIT
Forward current	I_F	2				A

2.4 I_{FSM} (forward current, surge peak)

I_{FSM} represent diode maximum non-repetitive sustain single surge current. It noted at specific test pulse time and ambient temperature (T_A=25°C). Consider rectifier used by AC rectification application in frequency 60Hz, rectifier usually note I_{FSM} specification which test period of single half sine wave surge time is 8.3ms for customer reference.

Take TSC datasheet “ES2BFSH – ES2JFSH” I_{FSM} spec as example:

ABSOLUTE MAXIMUM RATINGS (TA = 25°C unless otherwise noted)							
PARAMETER		SYMBOL	ES2BFSH	ES2DFSH	ES2GFSH	ES2JFSH	UNIT
Surge peak forward current, single half sine-wave superimposed on rated load	t = 8.3ms	I _{FSM}	50				A
	t = 1.0ms		120				A

2.5 T_J (junction temperature)

T_J is the allowable operating diode junction temperature. There is a range for user follow, like -55°C to +150°C. Diode can’t be used to exceed this temperature range, otherwise diode will be malfunction.

Take TSC datasheet “ES2BFSH – ES2JFSH” T_J spec as example:

ABSOLUTE MAXIMUM RATINGS (TA = 25°C unless otherwise noted)							
PARAMETER		SYMBOL	ES2BFSH	ES2DFSH	ES2GFSH	ES2JFSH	UNIT
Junction temperature		T _J	-55 to +150				°C

2.6 T_{STG} (storage temperature)

T_{STG} is the allowable storage ambient temperature. There is a range for user follow, like -55°C to +150°C. Diode can’t be stored to exceed this temperature range, otherwise diode will be malfunction.

Take TSC datasheet “ES2BFSH – ES2JFSH” T_J spec as example:

ABSOLUTE MAXIMUM RATINGS (TA = 25°C unless otherwise noted)							
PARAMETER		SYMBOL	ES2BFSH	ES2DFSH	ES2GFSH	ES2JFSH	UNIT
Storage temperature		T _{STG}	-55 to +150				°C

3. Static electrical characteristic

3.1 V_F (forward voltage)

When diode applied forward bias, there is a bias between device cathode and anode while specific forward current flow through the diode is called V_F . The V_F data will be tested and give specification by specific I_F (forward current), it might be the diode maximum allowable I_F and a half of the maximum allowable I_F . It also might offer the typical value and maximum limit specification for user's application reference. V_F also has specification by different PN junction temperature for user's application reference, for example $T_J=25^\circ\text{C}$, $T_J=125^\circ\text{C}$.

As rectifier diode chip material is Silicon, so the silicon semiconductor diode needs over forward bias $V_T=0.7\text{V}$ to let diode in conduction. The V_F curve will behave a resistance status while I_F increase, so there will be a r_d (average dynamic resistance) to describe the I-V curve slope. The equivalent model of represent diode V_F as below and I-V curve as (Figure 2):

$$V_F = V_T + r_d \times I_F$$

V_F value level could contribute power dissipation while diode operate in on-state status. The diode forward conduction power dissipation can be calculated by:

$$P_D = V_T \times I_F + r_d \times I_F^2$$

The diode forward conduction power dissipation also can be calculated by simple model formula, it will be robust concern for design:

$$P_D = V_F \times I_F$$

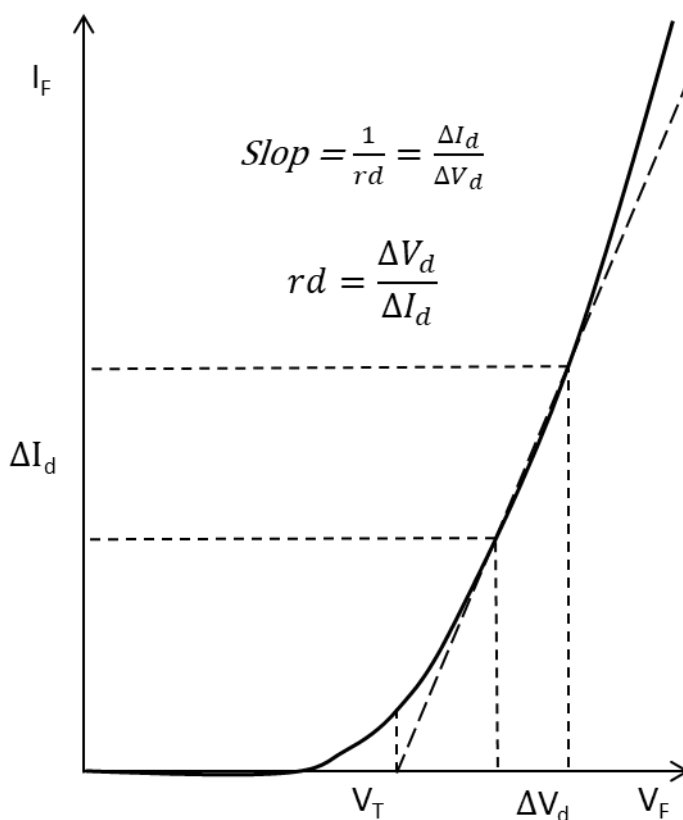

Figure 2 – Forward voltage drop V_F relate to I_F and equivalent model

Take TSC datasheet “ES2BFSH – ES2JFSH” V_F spec as example:

ELECTRICAL SPECIFICATIONS (TA = 25°C unless otherwise noted)						
PARAMETER		CONDITIONS	SYMBOL	TYP	MAX	UNIT
Forward voltage	ES2BFSH	$I_F = 1A, T_J = 25^\circ C$	V_F	0.82	-	V
		$I_F = 2A, T_J = 25^\circ C$		0.88	0.95	V
	ES2DFS	$I_F = 1A, T_J = 125^\circ C$		0.66	-	V
		$I_F = 2A, T_J = 125^\circ C$		0.74	0.84	V

3.2 I_R (reverse current)

I_R represent the current flow from external circuit through diode cathode to anode, it will be measured while diode under reverse bias. The I_R data will be tested and give specification by diode V_{BR} (breakdown voltage), It might offer the maximum limit specification for user’s application reference. I_R also has specification by different PN junction temperature for user’s application reference, for example $T_J=25^\circ C, T_J=125^\circ C$.

When diode applied reverse voltage at it, there is low current flow through diode cathode to anode, it is called the I_R (reverse current, also called leakage current). The I_R magnitude depends on diode block voltage capability and junction temperature degree. I_R value level could contribute power dissipation while diode in off-state status. The diode blocking mode power dissipation can be calculated by:

$$P_D = V_{BR} \times I_R$$

Take TSC datasheet “ES2BFSH – ES2JFSH” I_R spec as example:

ELECTRICAL SPECIFICATIONS (TA = 25°C unless otherwise noted)					
PARAMETER	CONDITIONS	SYMBOL	TYP	MAX	UNIT
Reverse current @ rated V_R	$T_J = 25^\circ\text{C}$	I_R	-	1	μA
	$T_J = 125^\circ\text{C}$		-	25	μA

3.3 T_{rr} (reverse recovery time)

T_{rr} represent diode PN junction flooding electron carriers in on-state phase need to be removed before diode act in off-state of reverse voltage. In ideal diode model, we hope diode could transfer on-state to off-state instantaneously while applying reverse bias to diode. However every material exist minority carrier, the minority carrier need response time to recover majority carrier status. This response time is called T_{rr} . Diode and rectifier adopt two appropriate conditions to measure T_{rr} :

3.3.1 Test condition B1

The condition is relevant to low, medium current output rectifiers with maximum specified recovery times of 50 to 3000 ns. The T_{rr} represents the time between the instant while forward current $I_F=0.5\text{A}$ pass through zero to the reverse direction, after reverse current reaches $I_{RM(REC)} = 1\text{A}$ peak reverse current and reach to a specified low value $i_{R(REC)} = 0.25\text{A}$ as (Figure 3).

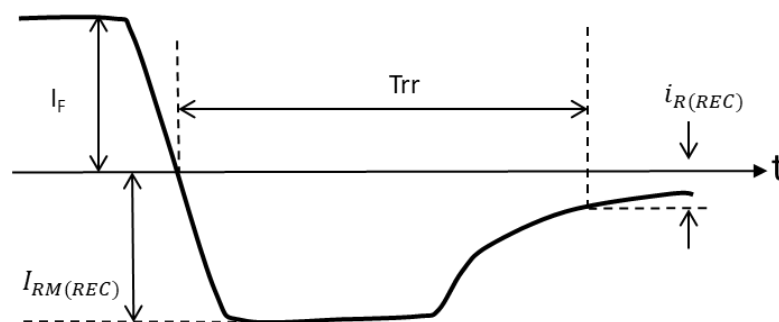

Figure 3 – Reverse recovery waveform for condition B1

Take TSC datasheet “ES2BFSH – ES2JFSH” I_R spec as example:

ELECTRICAL SPECIFICATIONS (TA = 25°C unless otherwise noted)					
PARAMETER	CONDITIONS	SYMBOL	TYP	MAX	UNIT
Reverse recovery time	$I_F = 0.5\text{A}, I_R = 1.0\text{A}, I_{rr} = 0.25\text{A}$	t_{rr}	-	35	ns

3.3.2 Test condition D

The condition is relevant to Ultra-fast rectifiers, particularly on new specifications. The T_{rr} represents the time between the instant while forward current I_F pass through zero to the reverse direction, after reverse current reaches $I_{RM(REC)}$ peak reverse current and the cross axial point at which the line reaches a specified low value $I_{R(REC)} = 0.25 I_{RM(REC)}$. The conditions of I_F , di/dt , V_R shall be specified, it may result the T_{rr} value. Waveform is as (Figure 4).

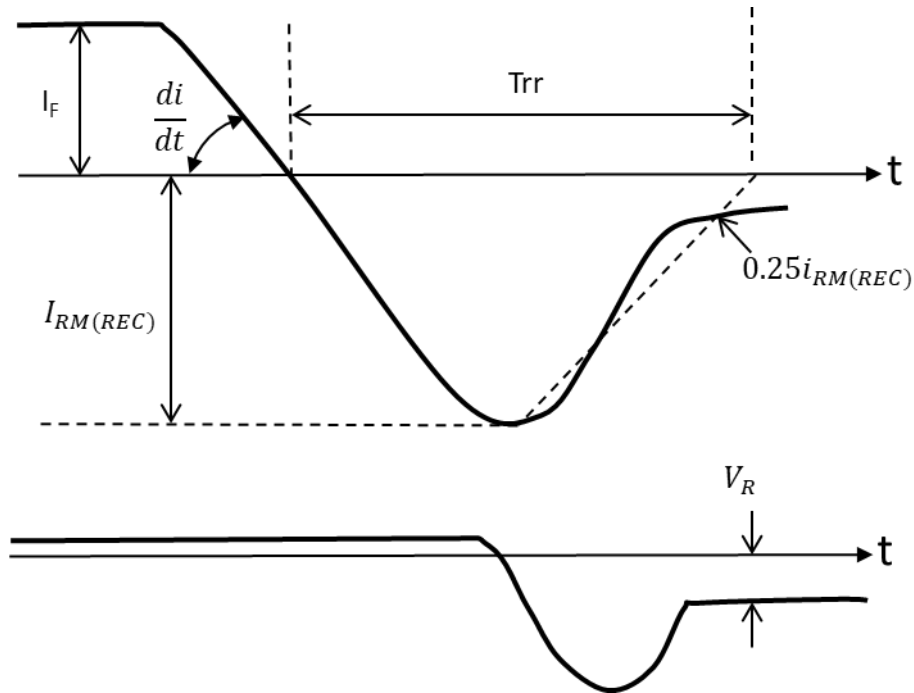

Figure 4 – Reverse recovery waveform for condition D

3.3.3 T_{rr} relate to turn off loss

T_{rr} current flow in the diode can have the turn off power loss while switch device turn off and apply V_R blocking reverse voltage to diode as (Figure 5). The recovery charge can be expressed by formula:

$$Q_{rr} = I_{RM(REC)} \times \frac{T_{rr}}{2}$$

The loss energy can be calculated by formula:

$$E_D = I_{RM(REC)} \times V_R \times \frac{T_{rr}}{2}$$

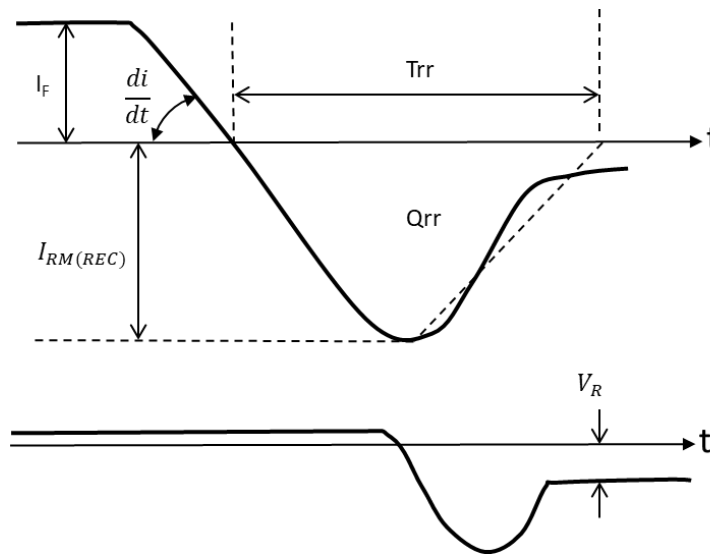

Figure 5 – Diode reverse recovery charge according T_{rr} and switch device turn off to apply V_R to diode waveform

3.3.4 RRSF (reverse recovery softness factor)

T_{rr} value could be affected depends by diode internal capacitance and external circuit structure. It includes I_F flow through the diode before it turn off, diode di/dt fall slope affected by the circuit, and V_R applied to the diode. Besides T_{rr} specification, RRSF is another reverse recovery feature that could be monitor in applications. RRSF is the absolute value of ratio of di_f/dt (the rate of fall reverse recovery current pass through zero axis) to di_r/dt (the rate of raise reverse current after the current pass through I_{RM}) and the curve description is as (Figure 6):

$$RRSF = \left| \frac{di_f/dt}{di_r/dt} \right|$$

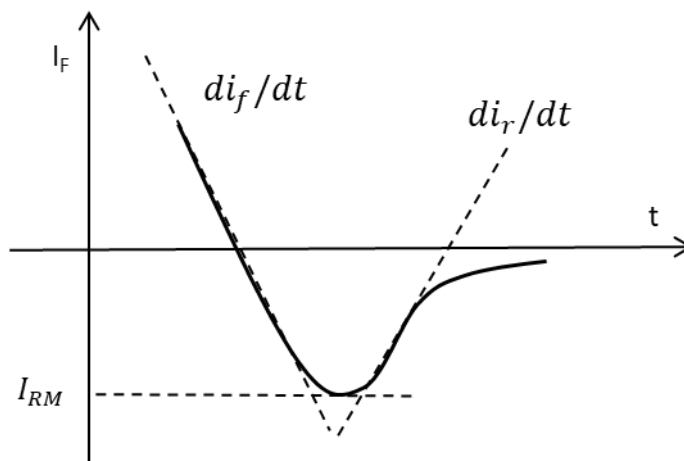

Figure 6 – RRSF (reverse recovery softness factor)

RRSF could be defined to “soft recovery” (Figure 7) and “abrupt recovery” (Figure 8). Abrupt recovery behavior, the T_{rr} is small and could have low switch power loss. Although that, Abrupt recovery not only could suffer EMI issue but also the di/dt rapid current change with circuit inductance will suffer transient voltage (Ldi/dt). The induce peak voltage might exceed diode maximum V_{BR} and damage diode. Soft recovery behavior, it could reduce the EMI and induce peak voltage issue. But the T_{rr} is big, it might increase switch power loss. So the T_{rr} behavior between “soft recovery” and “abrupt recovery” shows a trade-off of reduce switch power loss or reduce inductor induce voltage, reduce EMI issue.

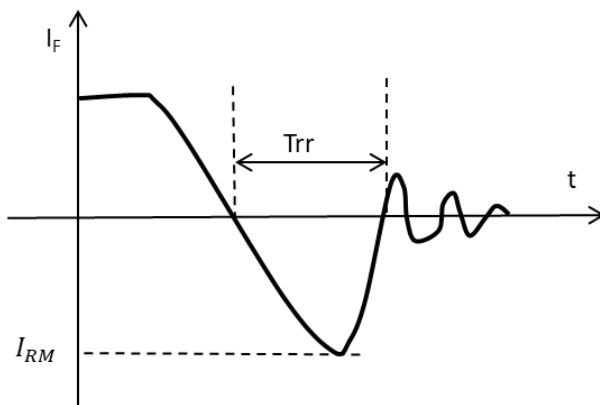

Figure 7 – abrupt recovery

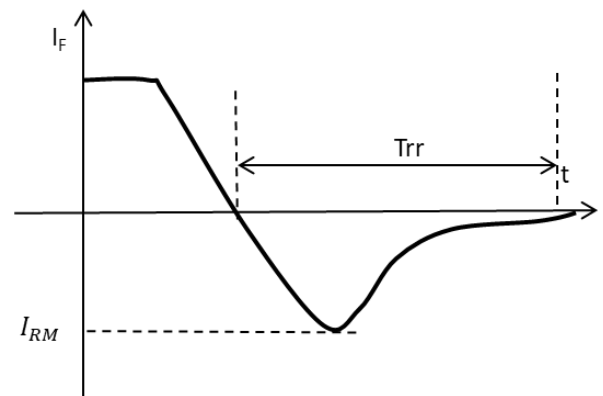

Figure 8 – soft recovery

3.4 C_j (junction capacitance)

The capacitance between the diode terminals of a complete device. C_j is measured at specific V_R reverse voltage, the value will decrease as V_R raising.

Take TSC datasheet “ES2BFSH – ES2JFSH” C_j spec as example:

ELECTRICAL SPECIFICATIONS (TA = 25°C unless otherwise noted)						
PARAMETER		CONDITIONS	SYMBOL	TYP	MAX	UNIT
Junction capacitance	ES2BFSH ES2JFSH	1MHz, $V_R = 4.0V$	C_j	28	-	pF

3.5 V_{FM} (peak forward voltage)

V_{FM} is the maximum instantaneous forward voltage under specific I_F . t_{fr} is the time between V_{FM} raising and flow to 10% V_{FM} as (Figure 9). Diode turn on could have V_{FM} and it can contribute the turn on energy loss, the calculation turn on loss formula:

$$E = V_{FM} \times I_F \times t_{fr}$$

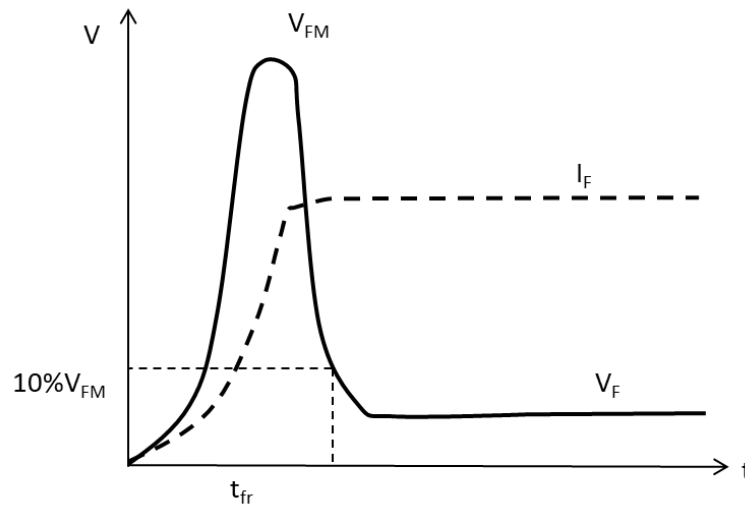

Figure 9 – V_{FM} waveform when diode turn on state

3.6 R_{thjx}, Z_{thjx} (thermal resistance, thermal impedance)

3.6.1 R_{thjx} (thermal resistance)

Steady-state the temperature difference between two specific points divided by the power dissipation under thermal equilibrium. The thermal resistance is defined:

$$R_{thjx} = \frac{T_j - T_{A,C,L}}{P_{F(AV)}} = \frac{T_j - T_{A,C,L}}{V_{F(HTG)} \times I_{F(HTG)}}$$

$$T_j = T_{j0} + \Delta T_j$$

$$\Delta T_j = K \times \Delta TSP$$

T_j = device junction temperature

$T_{A,C,L}$ = reference temperature for specific environment

$I_{F(HTG)}$ = heating current

$V_{F(HTG)}$ = V_F value when $I_{F(HTG)}$ applied

T_{j0} = device junction temperature before heating current apply

ΔT_j = temperature raising after heating current applied

ΔTSP = change value of temperature sensitive parameter (mV)

K = constant relationship between changes of T_j and TSP temperature sensitive parameter (°C/mV)

Thermal resistance includes:

R_{thjA} (junction-to-ambient thermal resistance): The thermal resistance from device junction to ambient.

R_{thjC} (junction-to-case thermal resistance): The thermal resistance from device junction to case.

R_{thjL} (junction-to-lead thermal resistance): The thermal resistance from device junction to lead.

Take TSC datasheet “ES2BFSH – ES2JFSH” R_{thjx} spec as example:

THERMAL PERFORMANCE			
PARAMETER	SYMBOL	TYP	UNIT
Junction-to-lead thermal resistance	$R_{\theta JL}$	24	°C/W
Junction-to-ambient thermal resistance	$R_{\theta JA}$	72	°C/W
Junction-to-case thermal resistance	$R_{\theta JC}$	14	°C/W

Thermal Performance Note: Units mounted on PCB (5mm x 5mm Cu pad test board)

3.6.2 Z_{thjx} (thermal impedance)

Transient the temperature difference between two specific points divided by the power dissipation, transient thermal impedance is the value of the device short pulse duration power handling ability.

The thermal impedance is defined:

$$Z_{thjx} = \frac{T_{j(t)} - T_R}{P_{F(AV)}} = \frac{(V_{F(MET)1} - V_{F(MET)2}) \times K}{V_{F(HTG)} \times I_{F(HTG)}}$$

T_R = junction temperature before heating pulse of duration time

$T_{j(t)}$ = junction temperature after heating pulse of duration time

$V_{F(MET)1}$ = Value of metering forward voltage

$V_{F(MET)2}$ = Value of metering forward voltage

Thermal impedance includes:

Z_{thjC} (junction-to-case thermal impedance): The thermal impedance from device junction to case

3.7 E_{AS} (Non-repetitive avalanche energy)

The inductor load occurs avalanche surge current to diode when the circuit from on-state to off-state. E_{AS} represent the diode maximum sustain single pulse avalanche surge capability and test circuit as (Figure 10). Inductor is charged while switch device turn on, inductor will be charged to I_{AS}. Switch device turn off, the inductor will discharge energy to diode and make diode in V_{BR(diode)}. The cross area of I_{AS} and V_{BR(diode)} is the E_{AS}:

$$E_{AS} = \frac{1}{2} \times L \times I_{AS}^2 \times \left(\frac{V_{BR(diode)}}{V_{BR(diode)} - V_{DD}} \right)$$

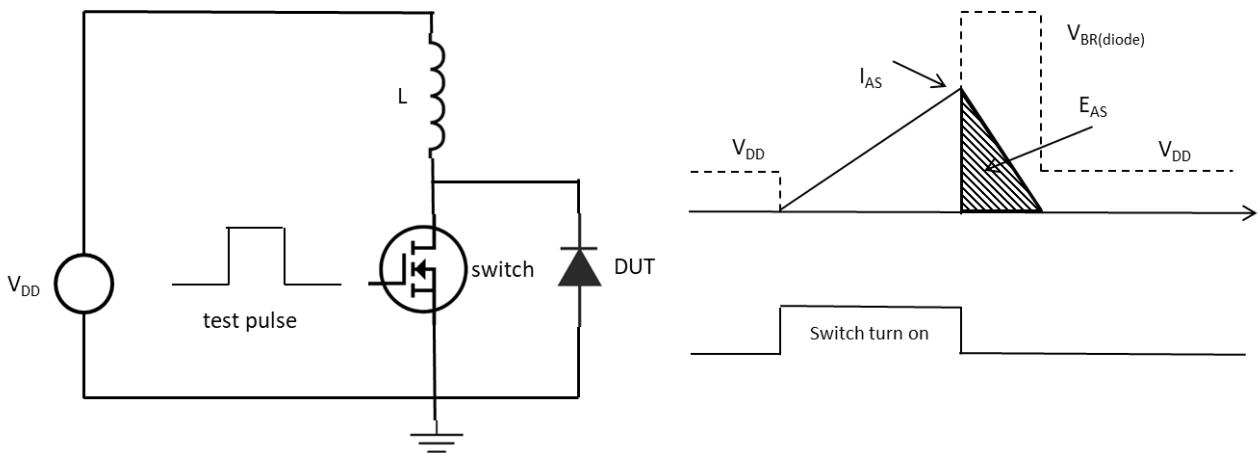

Figure 10 – E_{AS} test circuit and waveform

4. Characteristics curves

Take TSC datasheet “ES2BFSH – ES2JFSH” as example to describe the diode characteristic curve

4.1 Forward Current Derating Curve

The curve describe device $I_{F(AV)}$ declines according temperature raising until device maximum T_j . Curve is as (Figure 11) and the relationship formula:

$$T_{j(maximum)} = T_{A,C,L} + I_{F(AV)} \times V_{F(maximum Tj)} \times R_{thjA,C,L}$$

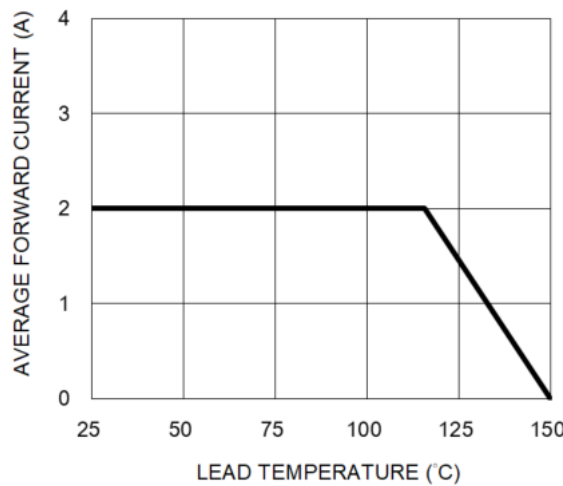

Figure 11 - Forward Current Derating Curve

4.2 Typical Forward Characteristics

The curve represents V_F value by different I_F conditions, and V_F negative temperature coefficient. V_F will decrease according temperature increase as (Figure 12).

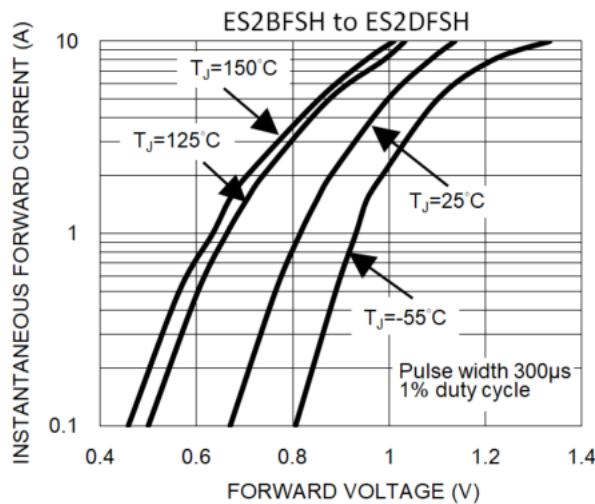

Figure 12 - Typical Forward Characteristics

4.3 Typical Reverse Characteristics

The curve represents I_R value by different V_R conditions, and I_R positive temperature coefficient. I_R will increase according temperature increase as (Figure 13).

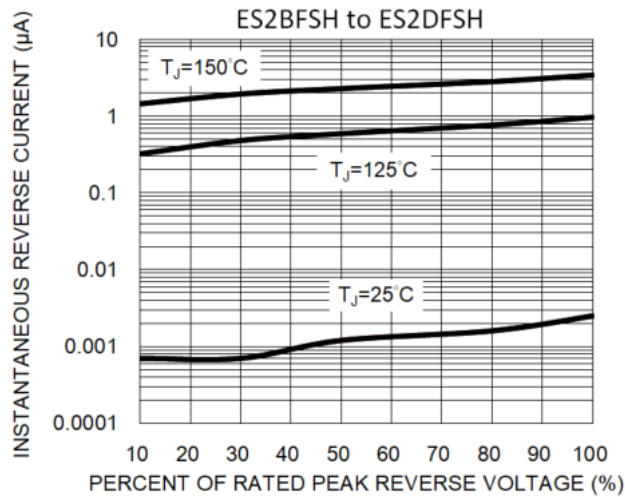

Figure 13 - Typical Reverse Characteristics

4.4 Typical Junction Capacitance

The curve describe device junction capacitance variant at different V_R . It will decrease as reverse voltage increase as (Figure 14).

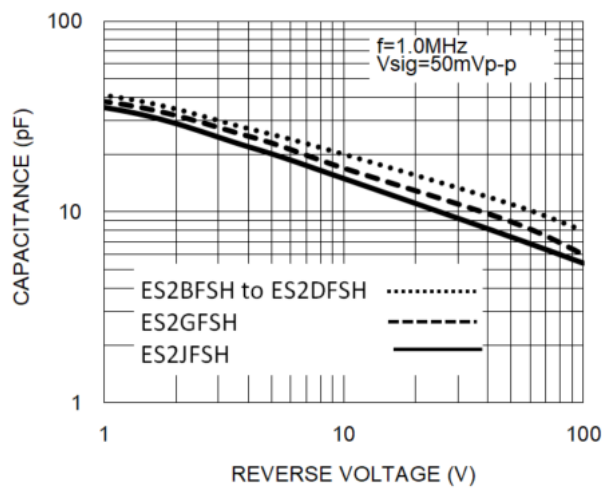

Figure 14 - Typical Junction Capacitance

4.5 Typical Transient Thermal Impedance

The curve represents the junction-to-case transient thermal impedance Z_{thjc} during different pulse duration. It will go to steady-state as time going on as (Figure 15)

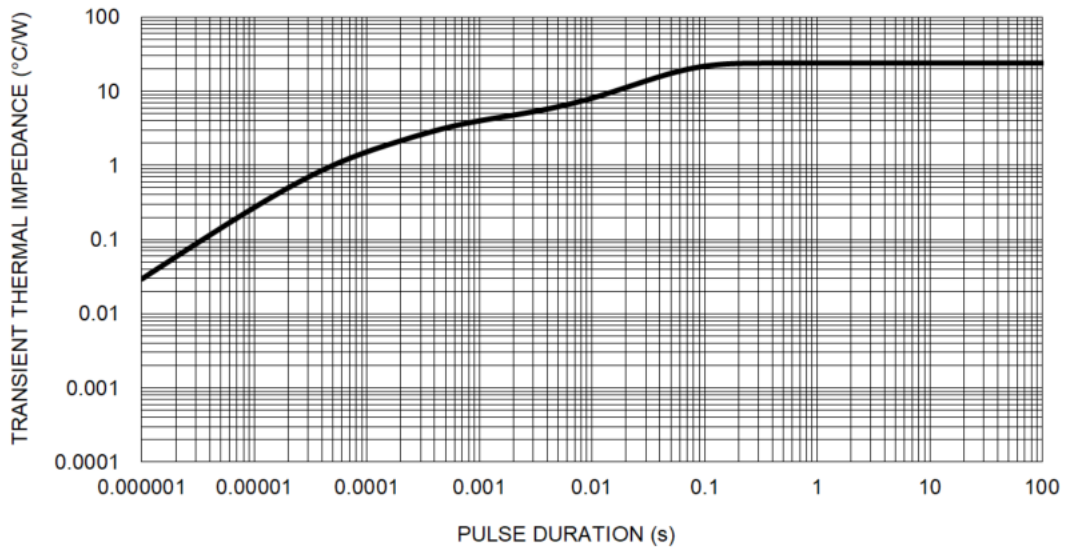

Figure 15 - Typical Transient Thermal Impedance

Reference

- [1] JEDEC Solid State Technology Association: JESD77D. "Terms, Definitions, and Letter Symbols for Discrete Semiconductor and Optoelectronic Devices", 2009.
- [2] JEDEC Solid State Technology Association: JESD104C.01. "Reference Guide to Letter Symbols for Semiconductor Devices", 2002.
- [3] JEDEC Solid State Technology Association: JESD282B.01

Authors

Ken Kan : Application Engineer Assistant Manager: ken_kan@mail.ts.com.tw
 HL Lin : Product Application Manager: hl_lin@mail.ts.com.tw

Taiwan Semiconductor Co., Ltd.

Headquarters

Address: 11F. No. 25 Sec. 3, Beishin Rd, Shindian District, New Taipei City, Taiwan R.O.C.
 Telephone: +886-2-8913-1588
 E-mail: marketing@mail.ts.com.tw
 Website: www.taiwansemi.com