

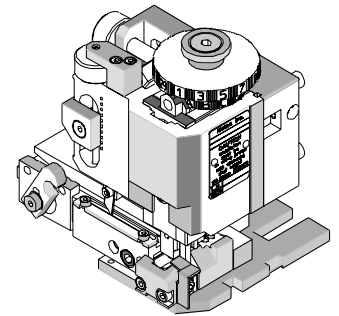

# FineAdjust Applicator Specification Sheet Part No. 63866-6100



## FEATURES

- Directly adapts to most automatic wire processing machines
- Quick punch removal with the push of a button for fast and easy tooling change
- Applicator designed to industry standard mounting and shut height 135.80mm (5.346")
- Quick set-up time; plus the crimp height, track and feed adjustments can be set without removing the applicator from the press
- Fine adjustment allows users to achieve target with little effort by adjusting in increments of .015mm (.0006") for conductor crimp height and .063mm (.0025") for insulation height
- Independent adjustment rings allow users to quickly adjust the conductor or insulation crimp height without affecting each other

## SCOPE

Products: MOX 0.635mm (.025") Receptacle Crimp Terminal, 22 AWG and (0.35-0.50mm<sup>2</sup>)

Terminal Series No.	Terminal Order No.	Wire Size	Actual mm <sup>2</sup>	Wire Type	Insulation Diameter		Strip Length	
					mm	In.	mm	In.
98658	98658-1213	0.35mm <sup>2</sup>	0.34	IR	1.25-1.40	.049-.055	2.60-3.30	.102-.130
		22 AWG	0.35	TXL	1.50-1.65	.059-.065		
		0.50mm <sup>2</sup>	0.50	ID	1.40-1.50	.055-.059		
		0.50mm <sup>2</sup>	0.50	IR	1.40-1.60	.055-.063		
	98658-1223	0.35mm <sup>2</sup>	0.34	IR	1.25-1.40	.049-.055		
		22 AWG	0.35	TXL	1.50-1.65	.059-.065		
		0.50mm <sup>2</sup>	0.50	ID	1.40-1.50	.055-.059		
		0.50mm <sup>2</sup>	0.50	IR	1.40-1.60	.055-.063		
	98658-1233	0.35mm <sup>2</sup>	0.34	IR	1.25-1.40	.049-.055		
		22 AWG	0.35	TXL	1.50-1.65	.059-.065		
		0.50mm <sup>2</sup>	0.50	ID	1.40-1.50	.055-.059		
		0.50mm <sup>2</sup>	0.50	IR	1.40-1.60	.055-.063		

## DEFINITION OF TERMS

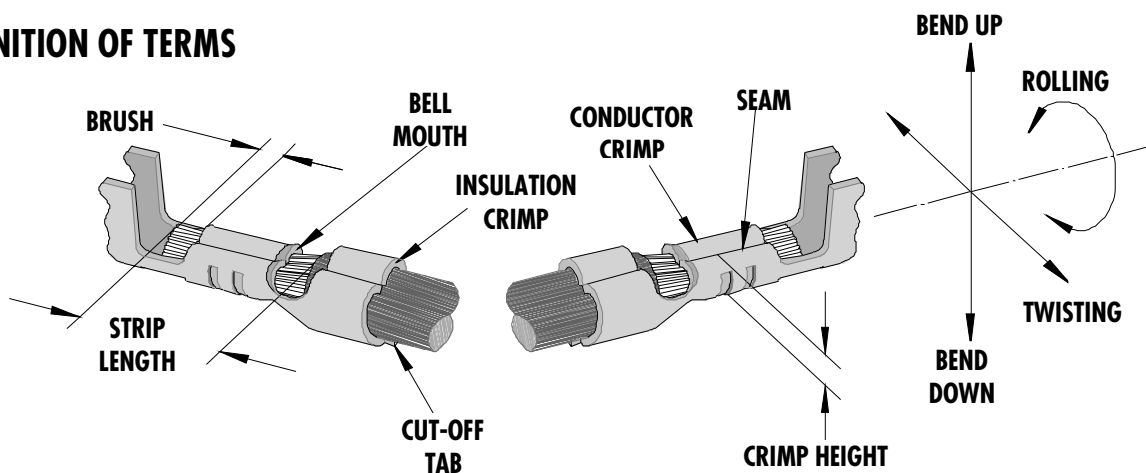

The above terminal drawing is a generic terminal representation. It is not an image of a terminal listed in the scope.

### CRIMP SPECIFICATION

Terminal Series No.	Bell mouth		Cut-off Tab Maximum		Conductor Brush	
	Mm	In.	mm	In.	mm	In.
98658	0.20-0.50	.008-.020	0.30	.012	0.10-0.50	.004-.020

Terminal Series No.	Bend up	Bend down	Twist	Roll	Punch Width (Ref)				Seam Seam shall not be open and no wire allowed out of the crimping area
					Conductor		Insulation		
	Degree	Degree	mm	In	mm	In			
98658	3	3	5	6	1.40	.055	1.80	.071	

After crimping, the conductor profile should measure the following.

Terminal Series No.	Wire Size	Actual mm <sup>2</sup>	Wire Type	Conductor			
				Crimp Height		Crimp Width (Ref)	
				mm	In.	mm	In.
98658	0.35mm <sup>2</sup>	0.34	IR	0.73-0.79	.029-.031	1.40	.055
	22 AWG	0.35	TXL	0.79-0.79	.029-.031		
	0.50mm <sup>2</sup>	0.50	ID	0.83-0.89	.033-.035		
	0.50mm <sup>2</sup>	0.50	IR	0.83-0.89	.033-.035		

Terminal Series No.	Wire Size	Actual mm <sup>2</sup>	Wire Type	Insulation				Pull Force Minimum	
				Crimp Height Maximum		Crimp Width (Ref)			
				mm	In.	mm	In.	N	Lb.
98658	0.35mm <sup>2</sup>	0.34	IR	1.76	.069	1.80	.071	60.0	13.50
	22 AWG	0.35	TXL	1.90	.075			60.0	13.50
	0.50mm <sup>2</sup>	0.50	ID	1.90	.075			80.0	17.99
	0.50mm <sup>2</sup>	0.50	IR	1.90	.075			80.0	17.99

Pull Force should be measured with no influence from the insulation crimp.  
The above specifications are guidelines to an optimum crimp.

**PARTS LIST**

<b>FineAdjust Applicator 63866-6100</b>				
<b>Item</b>	<b>Order No</b>	<b>Engineering No.</b>	<b>Description</b>	<b>Quantity</b>
<b>Perishable Tooling</b>				
	63866-6170	63866-6170	Tool Kit (All "Y" Items)	REF
1	63444-1428	63444-1428	Conductor Punch	1 Y
2	63455-0018	63455-0018	Conductor Anvil	1 Y
3	63454-0030	63454-0030	Insulation Punch	1 Y
4	63456-0026	63456-0026	Insulation Anvil	1 Y
5	63443-0003	63443-0003	Front Cut-Off Plunger	1 Y
6	63443-0012	63443-0012	Front Plunger Retainer	1 Y
<b>Other Components(REF 666050)</b>				
7	11-18-4083	60707-8	Feed Guide	1
8	11-24-1067	4996-4	Cut-Off Plunger Spring	1
9	11-40-4039	8302-5	Plunger Striker	1
10	63443-0009	63443-0009	Front Scrap Chute	1
11	63443-0024	63443-0024	Key	1
12	63443-0092	63443-0092	Wire Stop	1
13	63443-1716	63443-1716	18.60mm Spacer	1
14	63443-2215	63443-2215	15.00mm Spacer	1
15	63443-2314	63443-2314	3.70mm Spacer	1
16	63443-6117	63443-6117	Rear Cover	1
<b>Frame</b>				
17	63800-4901	63800-4901	Top	1
18	63801-3281	63801-3281	Base	1
19	63801-4650	63801-4650	Track	1
<b>Hardware</b>				
20	N/A	N/A	M3 by 6 Long SHCS	2**
21	N/A	N/A	M3 by 6 Long FHCS	1**
22	N/A	N/A	M4 by 6 Long SHCS	2**
23	N/A	N/A	M4 by 12 Long BHCS	2**
24	N/A	N/A	M4 by 50 Long SHCS	2**
25	N/A	N/A	M5 by 12 Lg SHCS	1**
26	N/A	N/A	#10-32 by 3/8" Long Flat Point SSS	1**
27	N/A	N/A	#10-32 Hex Jam Nut	1**
** Available from an industrial supply company such as MSC (1-800-645-7270).				

### Assembly Drawing

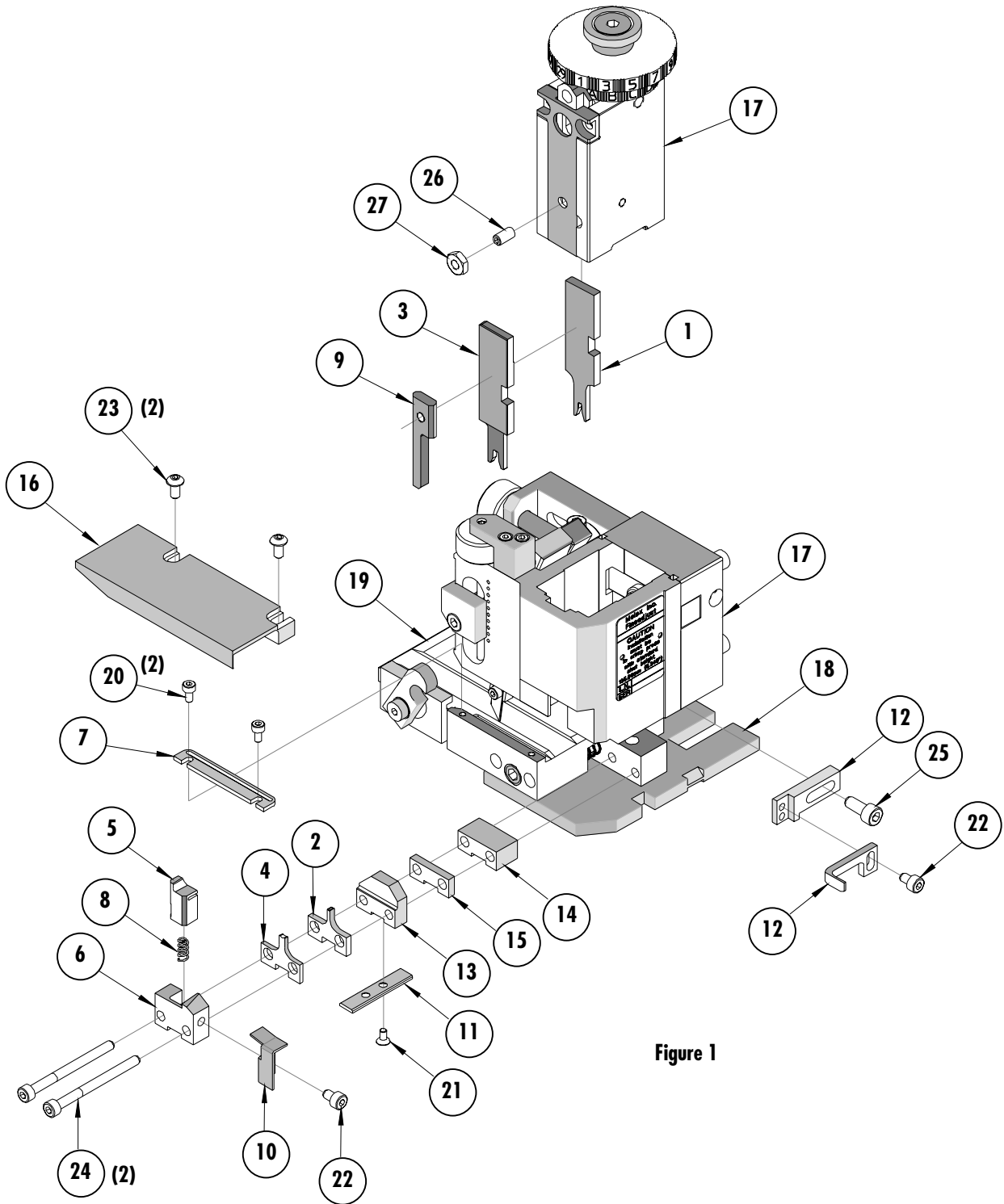

Figure 1

## NOTES

1. Molex recommends an extra perishable tooling kit be maintained at your facility.
2. Verify tooling alignment by manually cycling the press and Applicator before crimping under power. Check that all screws are tight.
3. Slugs, Terminals, Dirt and Oil should be kept clear of work area.
4. Wear safety glasses at all times.
5. For recommended maintenance refer to the FineAdjust Manual.

**CAUTION:** This applicator should only be used in a press with a shut height of 135.8mm (5.346"). Tooling damage could result at a lower setting.

**CAUTION:** To prevent injury never operate this Applicator without the guards supplied with the press or wire-processing machine in place. Reference the press or wire processing manufacturer's instruction manual.

**CAUTION:** Molex crimp specifications are valid only when used with Molex terminals, applicators and tooling.

**Americas Headquarters**

Lisle, Illinois 60532 U.S.A.  
1-800-78MOLEX  
amerinfo@molex.com

**Far East North Headquarters**

Yamato, Kanagawa, Japan  
81-462-65-2324  
feninfo@molex.com

**Far East South Headquarters**

Jurong, Singapore  
65-6-268-6868  
fesinfo@molex.com

**European Headquarters**

Munich, Germany  
49-89-413092-0  
eurinfo@molex.com

**Corporate Headquarters**

2222 Wellington Ct.  
Lisle, IL 60532 U.S.A.  
630-969-4550  
Fax: 630-969-1352

Visit our Web site at <http://www.molex.com>