

TERMINALS ARE TO BE ORIENTED AND LOADED  
IN TO THE HOUSING AS SHOWN ABOVE

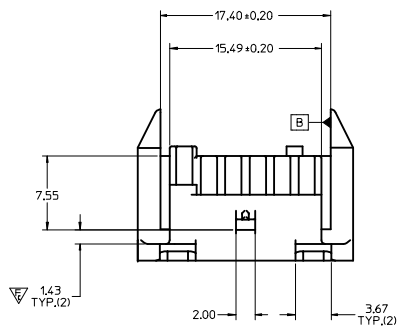
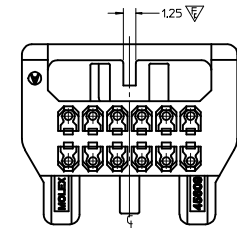
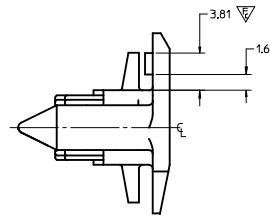
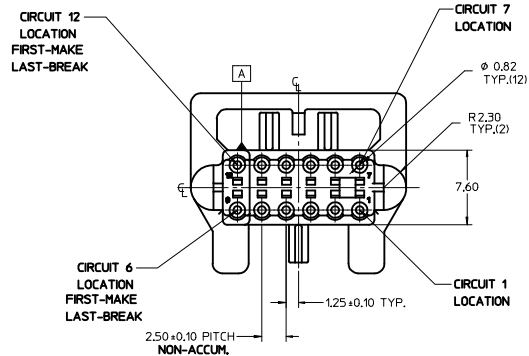

NOTES:

1. MATERIAL: POLYESTER, UL94V-0, COLOR: BLACK.
2. PRODUCT SPECIFICATION: TBD.
3. USES FEMALE CRIMP TERMINALS, SERIES 5263. (NOTE ORIENTATION OF TERMINALS)
4. PART MATES WITH MOLEX HEADER ASSEMBLY SERIES 45608.
5. PACKAGING: BULK.
6. SEE PAGE 2 OF 2 FOR PANEL CUOUT DIMENSIONS AND THE ALLOWED BOARD TO PANEL MISALIGNMENT.
7. USE TOOL NUMBER 63813-1400 TO REMOVE TERMINALS FROM HOUSING WHEN NECESSARY. CAUTION: TERMINALS MUST NOT BE REUSED AFTER REMOVAL.

| <b>CHANGED STACK UP TO:</b><br>IEC NO: 12014-0049<br>DRAWN: BR02<br>CHKD:<br>APPR: KRASAD<br>2013/10/16<br>2013/10/18         | <b>QUALITY SYMBOLS</b><br>▽=0<br>▽=0<br>▽=6 | <b>GENERAL TOLERANCES (UNLESS SPECIFIED)</b>  |  | <b>DIMENSION STYLE</b><br>MM ONLY | <b>SCALE</b><br>4:1 | <b>DESIGN UNITS</b><br>METRIC | THIRD ANGLE PROJECTION |         |          |        |         |          |       |         |         |        |         |  |          |      |       |        |            |   |            |      |  |        |            |  |             |      |  |          |            |  |                                   |
|---|---|---|--|-----------------------------------|---------------------|-------------------------------|------------------------|---------|----------|--------|---------|----------|-------|---------|---------|--------|---------|--|----------|------|-------|--------|------------|---|------------|------|--|--------|------------|--|-------------|------|--|----------|------------|--|-----------------------------------|
|   |   | <table border="1"> <thead> <tr> <th></th> <th>mm</th> <th>INCH</th> </tr> </thead> <tbody> <tr> <td>4 PLACES</td> <td>± 0.3</td> <td>± 0.012</td> </tr> <tr> <td>3 PLACES</td> <td>± 0.25</td> <td>± 0.010</td> </tr> <tr> <td>2 PLACES</td> <td>± 0.2</td> <td>± 0.008</td> </tr> <tr> <td>1 PLACE</td> <td>± 0.15</td> <td>± 0.006</td> </tr> </tbody> </table> |  | mm                                | INCH                | 4 PLACES                      | ± 0.3                  | ± 0.012 | 3 PLACES | ± 0.25 | ± 0.010 | 2 PLACES | ± 0.2 | ± 0.008 | 1 PLACE | ± 0.15 | ± 0.006 | <table border="1"> <tr> <td>DRAWN BY</td> <td>DATE</td> <td>TITLE</td> </tr> <tr> <td>DROSCA</td> <td>09/06/2006</td> <td>SPOX BMI RECEPTACLE HOUSING, 12 PIN PANEL MOUNT</td> </tr> <tr> <td>CHECKED BY</td> <td>DATE</td> <td></td> </tr> <tr> <td>DROSCA</td> <td>09/06/2006</td> <td></td> </tr> <tr> <td>APPROVED BY</td> <td>DATE</td> <td></td> </tr> <tr> <td>JCOMERCI</td> <td>09/06/2006</td> <td></td> </tr> </table> | DRAWN BY | DATE | TITLE | DROSCA | 09/06/2006 | SPOX BMI RECEPTACLE HOUSING, 12 PIN PANEL MOUNT | CHECKED BY | DATE |  | DROSCA | 09/06/2006 |  | APPROVED BY | DATE |  | JCOMERCI | 09/06/2006 |  | <b>MATERIAL NO.</b><br>45609-0012 |
|   | mm  | INCH  |  |                                   |                     |                               |                        |         |          |        |         |          |       |         |         |        |         |  |          |      |       |        |            |   |            |      |  |        |            |  |             |      |  |          |            |  |                                   |
| 4 PLACES  | ± 0.3                                       | ± 0.012   |  |                                   |                     |                               |                        |         |          |        |         |          |       |         |         |        |         |  |          |      |       |        |            |   |            |      |  |        |            |  |             |      |  |          |            |  |                                   |
| 3 PLACES  | ± 0.25                                      | ± 0.010   |  |                                   |                     |                               |                        |         |          |        |         |          |       |         |         |        |         |  |          |      |       |        |            |   |            |      |  |        |            |  |             |      |  |          |            |  |                                   |
| 2 PLACES  | ± 0.2                                       | ± 0.008   |  |                                   |                     |                               |                        |         |          |        |         |          |       |         |         |        |         |  |          |      |       |        |            |   |            |      |  |        |            |  |             |      |  |          |            |  |                                   |
| 1 PLACE   | ± 0.15                                      | ± 0.006   |  |                                   |                     |                               |                        |         |          |        |         |          |       |         |         |        |         |  |          |      |       |        |            |   |            |      |  |        |            |  |             |      |  |          |            |  |                                   |
| DRAWN BY  | DATE  | TITLE   |  |                                   |                     |                               |                        |         |          |        |         |          |       |         |         |        |         |  |          |      |       |        |            |   |            |      |  |        |            |  |             |      |  |          |            |  |                                   |
| DROSCA  | 09/06/2006                                  | SPOX BMI RECEPTACLE HOUSING, 12 PIN PANEL MOUNT   |  |                                   |                     |                               |                        |         |          |        |         |          |       |         |         |        |         |  |          |      |       |        |            |   |            |      |  |        |            |  |             |      |  |          |            |  |                                   |
| CHECKED BY  | DATE  |   |  |                                   |                     |                               |                        |         |          |        |         |          |       |         |         |        |         |  |          |      |       |        |            |   |            |      |  |        |            |  |             |      |  |          |            |  |                                   |
| DROSCA  | 09/06/2006                                  |   |  |                                   |                     |                               |                        |         |          |        |         |          |       |         |         |        |         |  |          |      |       |        |            |   |            |      |  |        |            |  |             |      |  |          |            |  |                                   |
| APPROVED BY   | DATE  |   |  |                                   |                     |                               |                        |         |          |        |         |          |       |         |         |        |         |  |          |      |       |        |            |   |            |      |  |        |            |  |             |      |  |          |            |  |                                   |
| JCOMERCI  | 09/06/2006                                  |   |  |                                   |                     |                               |                        |         |          |        |         |          |       |         |         |        |         |  |          |      |       |        |            |   |            |      |  |        |            |  |             |      |  |          |            |  |                                   |
| DRAFT WHERE APPLICABLE MUST REMAIN WITHIN DIMENSIONS  |   |   |  |                                   |                     |                               |                        |         |          |        |         |          |       |         |         |        |         |  |          |      |       |        |            |   |            |      |  |        |            |  |             |      |  |          |            |  |                                   |
| THIS DRAWING CONTAINS INFORMATION THAT IS PROPRIETARY TO MOLEX INCORPORATED AND SHOULD NOT BE USED WITHOUT WRITTEN PERMISSION |   |   |  |                                   |                     |                               |                        |         |          |        |         |          |       |         |         |        |         |  |          |      |       |        |            |   |            |      |  |        |            |  |             |      |  |          |            |  |                                   |

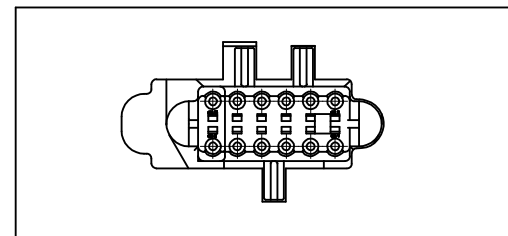
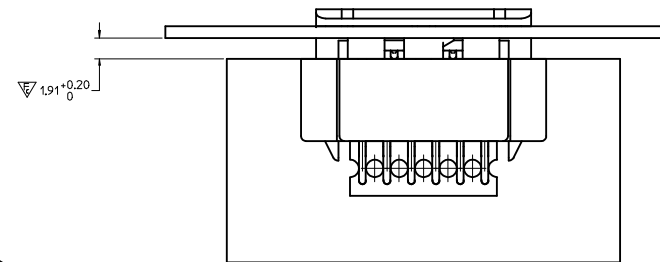
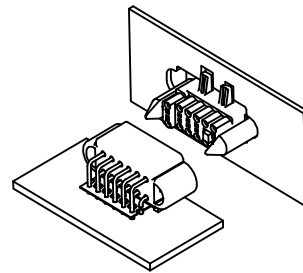
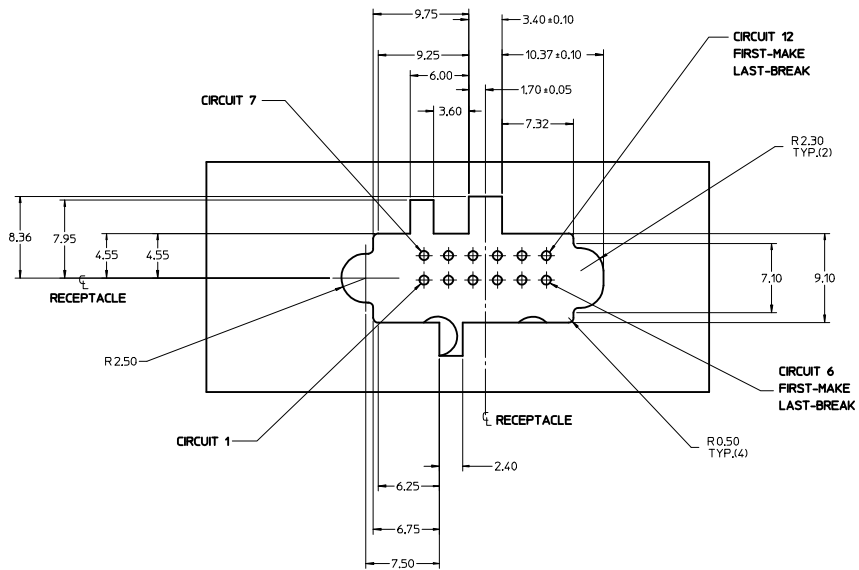

RECEPTACLE INSERT POSITIONING

PANEL CUTOUT  
PANEL THICKNESS 1.20±0.12MM

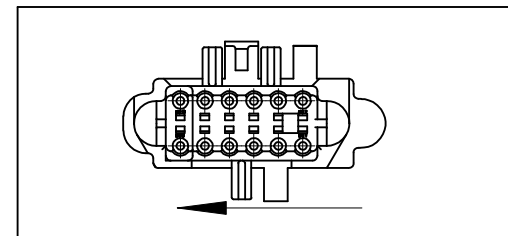
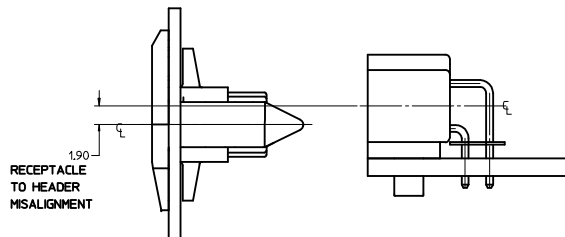
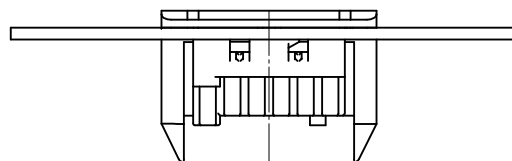

RECEPTACLE SLIDES INTO MOUNTED POSITION

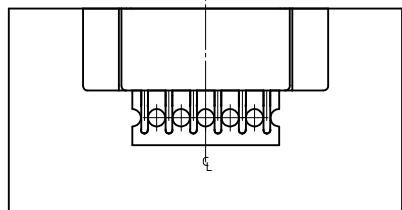

| <b>ENTER DESCRIPTION</b><br>IEC NO: 12014-0049<br>DRAWN BY: DRWNBROZ<br>CHYK:<br>APPR: KPRASAD<br>2013/10/16<br>2013/10/18<br>DESCRIPTION | QUALITY SYMBOLS<br>▽=0<br>▽=0<br>▽=1  |                                   | GENERAL TOLERANCES (UNLESS SPECIFIED)<br><table border="1"> <thead> <tr> <th></th> <th>mm</th> <th>INCH</th> </tr> </thead> <tbody> <tr> <td>4 PLACES</td> <td>±0.10</td> <td>±---</td> </tr> <tr> <td>3 PLACES</td> <td>±0.15</td> <td>±---</td> </tr> <tr> <td>2 PLACES</td> <td>±0.25</td> <td>±---</td> </tr> <tr> <td>1 PLACE</td> <td>±0.3</td> <td>±---</td> </tr> <tr> <td colspan="3">ANGULAR ±1/2°</td> </tr> </tbody> </table> |                                     |                    | mm                  | INCH                | 4 PLACES | ±0.10 | ±--- | 3 PLACES | ±0.15 | ±--- | 2 PLACES | ±0.25 | ±--- | 1 PLACE | ±0.3 | ±--- | ANGULAR ±1/2° |  |  | DIMENSION STYLE<br><b>MM ONLY</b> | SCALE<br><b>4:1</b> | DESIGN UNITS<br><b>METRIC</b> | THIRD ANGLE PROJECTION |
|---|---|-----------------------------------|---|-------------------------------------|--------------------|---------------------|---------------------|----------|-------|------|----------|-------|------|----------|-------|------|---------|------|------|---------------|--|--|-----------------------------------|---------------------|-------------------------------|------------------------|
|   |   | mm                                | INCH  |                                     |                    |                     |                     |          |       |      |          |       |      |          |       |      |         |      |      |               |  |  |                                   |                     |                               |                        |
|   | 4 PLACES  | ±0.10                             | ±---  |                                     |                    |                     |                     |          |       |      |          |       |      |          |       |      |         |      |      |               |  |  |                                   |                     |                               |                        |
|   | 3 PLACES  | ±0.15                             | ±---  |                                     |                    |                     |                     |          |       |      |          |       |      |          |       |      |         |      |      |               |  |  |                                   |                     |                               |                        |
| 2 PLACES  | ±0.25   | ±---                              |   |                                     |                    |                     |                     |          |       |      |          |       |      |          |       |      |         |      |      |               |  |  |                                   |                     |                               |                        |
| 1 PLACE   | ±0.3  | ±---                              |   |                                     |                    |                     |                     |          |       |      |          |       |      |          |       |      |         |      |      |               |  |  |                                   |                     |                               |                        |
| ANGULAR ±1/2°   |   |                                   |   |                                     |                    |                     |                     |          |       |      |          |       |      |          |       |      |         |      |      |               |  |  |                                   |                     |                               |                        |
| DRAWN BY: DROSCA<br>DATE: 09/06/2006<br>CHECKED BY: DATE:<br>DROSCA 09/06/2006<br>APPROVED BY: DATE:<br>JCOMERCI 09/06/2006               | MATERIAL NO:<br><b>45609-0012</b>   |                                   | TITLE<br><b>SPOX BMI RECEPTACLE HOUSING, 12 PIN PANEL MOUNT</b>   |                                     | MOLEX INCORPORATED |                     | SHEET NO.<br>2 OF 2 |          |       |      |          |       |      |          |       |      |         |      |      |               |  |  |                                   |                     |                               |                        |
| SIZE<br><b>D</b>  | THIS DRAWING CONTAINS INFORMATION THAT IS PROPRIETARY TO MOLEX INCORPORATED AND SHOULD NOT BE USED WITHOUT WRITTEN PERMISSION |                                   |   |                                     |                    |                     |                     |          |       |      |          |       |      |          |       |      |         |      |      |               |  |  |                                   |                     |                               |                        |
| DRAFT WHERE APPLICABLE MUST REMAIN WITHIN DIMENSIONS  |   | MATERIAL NO:<br><b>45609-0012</b> |   | DOCUMENT NO:<br><b>SD-45609-012</b> |                    | SHEET NO.<br>2 OF 2 |                     |          |       |      |          |       |      |          |       |      |         |      |      |               |  |  |                                   |                     |                               |                        |