

**SPECIFICATION
FOR
LCD Module**

Customer P/N:

Santek P/N: ST0240A1WY-RSLW-F

DOC. Revision: RS01

Customer Approval:

--

	SIGNATURE	DATE
PREPARED BY	Aaron Lu	2019-03-12
CHECKED BY	Andy Song	2019-5-22
APPROVED BY		2019.May.23th

Document Revision History

Version	Revise Date	Description	Changed by
RS01	2019-03-12	First issue	Aaron Lu

Santek \ CONFIDENTIAL

Table of Contents

1. GENERAL SPECIFICATION..... 4

2. BLOCK DIAGRAM..... 5

3. MECHANICAL DRAWING..... 6

4. INTERFACE ASSIGNMENT..... 7

5. ELECTRICAL SPECIFICATION..... 8

6. TOUCH PANEL SPECIFICATION 12

7. OPTICAL CHARACTERISTICS..... 13

8. RELIABILITY TESTS..... 17

9. PRECAUTIONS..... 18

10. LIMITED WARRANTY..... 18

Santek | CONFIDENTIAL

1. GENERAL SPECIFICATION

1.1 Description

The ST0240A1WY-RSLW-F is a color active matrix Thin Film Transistor (TFT) Liquid Crystal Display (LCD) that uses amorphous silicon(a-Si) TFT as a switching device. This model is composed of a single 2.4 inches transmissive type main TFT-LCD panel. The resolution of the panel is 240 x 320 pixels and can display up to 65K color.

1.2 Feature

- TN type for main TFT-LCD panel
- Structure COG+FPC+BL+RTP
- Full, Normal (Still), Partial, Sleep, Standby mode are available

1.3 General Specification

No.	Item	Specification	Unit	Remark
1	LCD Size	2.4	inch	-
2	Panel Type	a-Si TFT TRANSMISSIVE	-	-
3	Resolution	240 x (RGB) x 320	pixel	-
4	Display Mode	Normally White, Transmissive	-	-
5	Display Number of Colors	65K	-	-
6	Viewing Direction	6 o'clock	-	Note
7	Contrast Ratio	500(Typ)	--	
8	Luminance	350(Typ)	cd/m2	-
9	Module Size	42.70(W) x 61.15(L) x3.65(T)	mm	Note
10	Active Area	36.72(W) x 48.96(L)	mm	Note
11	Pixel Pitch	0.153(W) x 0.153(L)	mm	-
12	Weight	17(Reference)	g	-
13	Driver IC	ST7789V	-	-
14	Driver IC RAM Size	240X320X18	bits	-
15	Light Source	4 LEDs White	-	-
16	Interface	8/16 bit parallel	-	-
17	Operating Temperature	-20~70	°C	-
18	Storage Temperature	-30~80	°C	-

Note: Please refer to the mechanical drawing.

2. BLOCK DIAGRAM

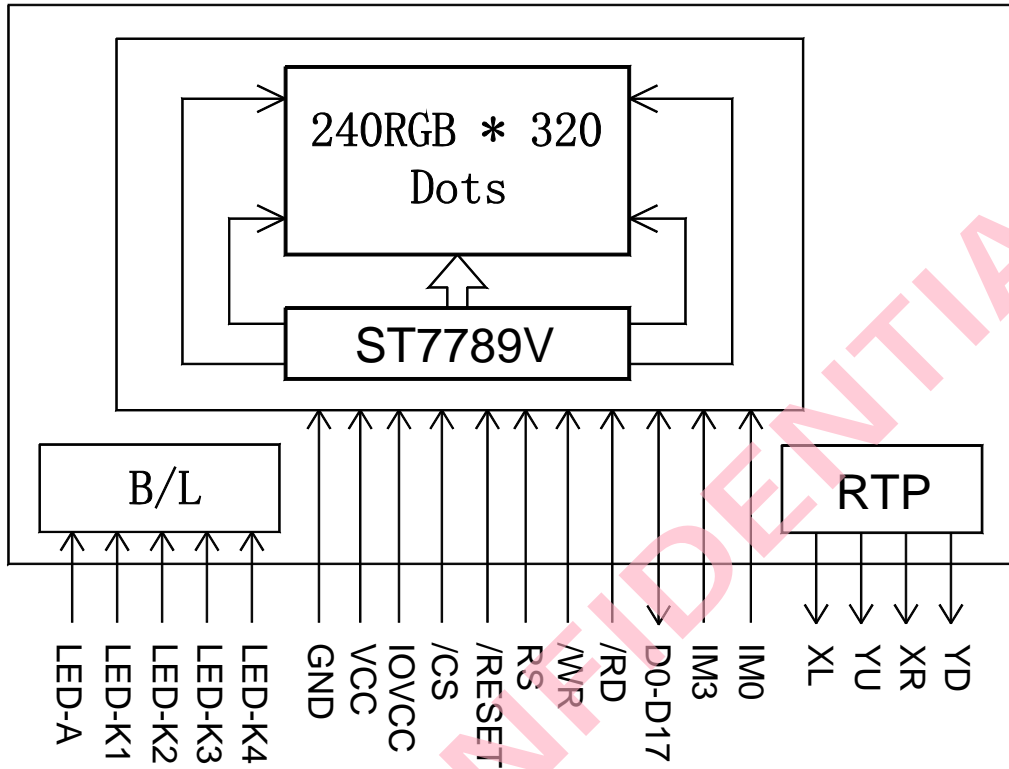

3. MECHANICAL DRAWING

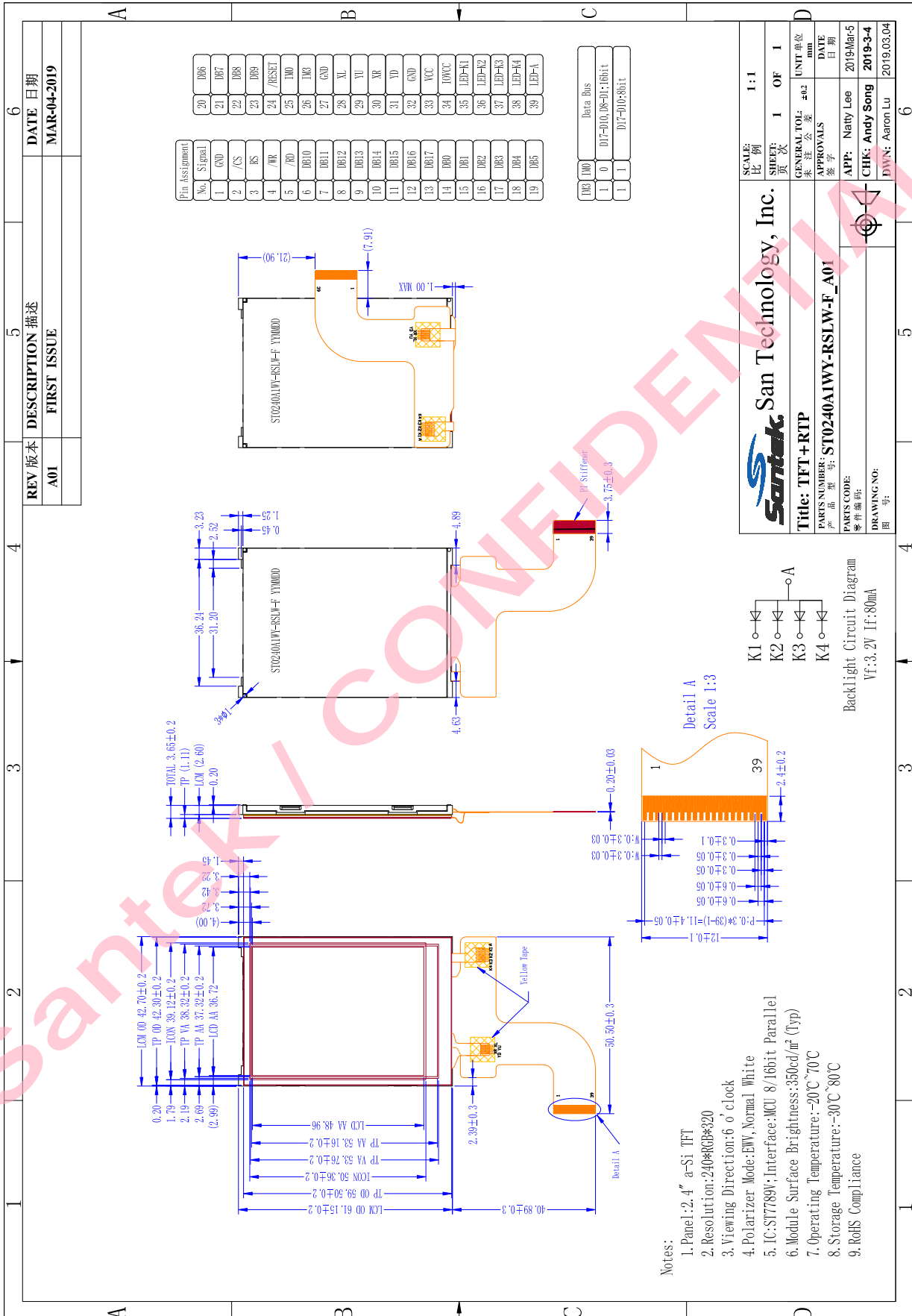

4. INTERFACE ASSIGNMENT

PIN NO.	SYMBOL	FUNCTION DESCRIPTIONS									
1	GND	Ground.									
2	/CS	Chip select signal.									
3	RS	Register select signal.									
4	/WR	Write signal.									
5	/RD	Read signal.									
6~13	DB10~DB17	Data bus.									
14~23	DB0~DB9	Data bus.									
24	/RESET	System reset pin.									
25	IM0	Interface mode select signal.									
26	IM3	<table border="1"> <thead> <tr> <th>IM3</th> <th>IM0</th> <th>Data Bus</th> </tr> </thead> <tbody> <tr> <td>1</td> <td>0</td> <td>D17-D10,D8-D1;16bits</td> </tr> <tr> <td>1</td> <td>1</td> <td>D17-D10;8bits</td> </tr> </tbody> </table>	IM3	IM0	Data Bus	1	0	D17-D10,D8-D1;16bits	1	1	D17-D10;8bits
		IM3	IM0	Data Bus							
		1	0	D17-D10,D8-D1;16bits							
1	1	D17-D10;8bits									
27	GND	Ground.									
28	XL	The left side signal of touch panel.									
29	YU	The up side signal of touch panel.									
30	XR	The right side signal of touch panel.									
31	YD	The down side signal of touch panel.									
32	GND	Ground.									
33	VCC	Power supply.									
34	IOVCC	I/O Power supply.									
35	LED-K1	LED Cathode 1.									
36	LED-K2	LED Cathode 2.									
37	LED-K3	LED Cathode 3.									
38	LED-K4	LED Cathode 4.									
39	LED-A	LED Anode.									

5. ELECTRICAL SPECIFICATION

5.1. Application Circuit

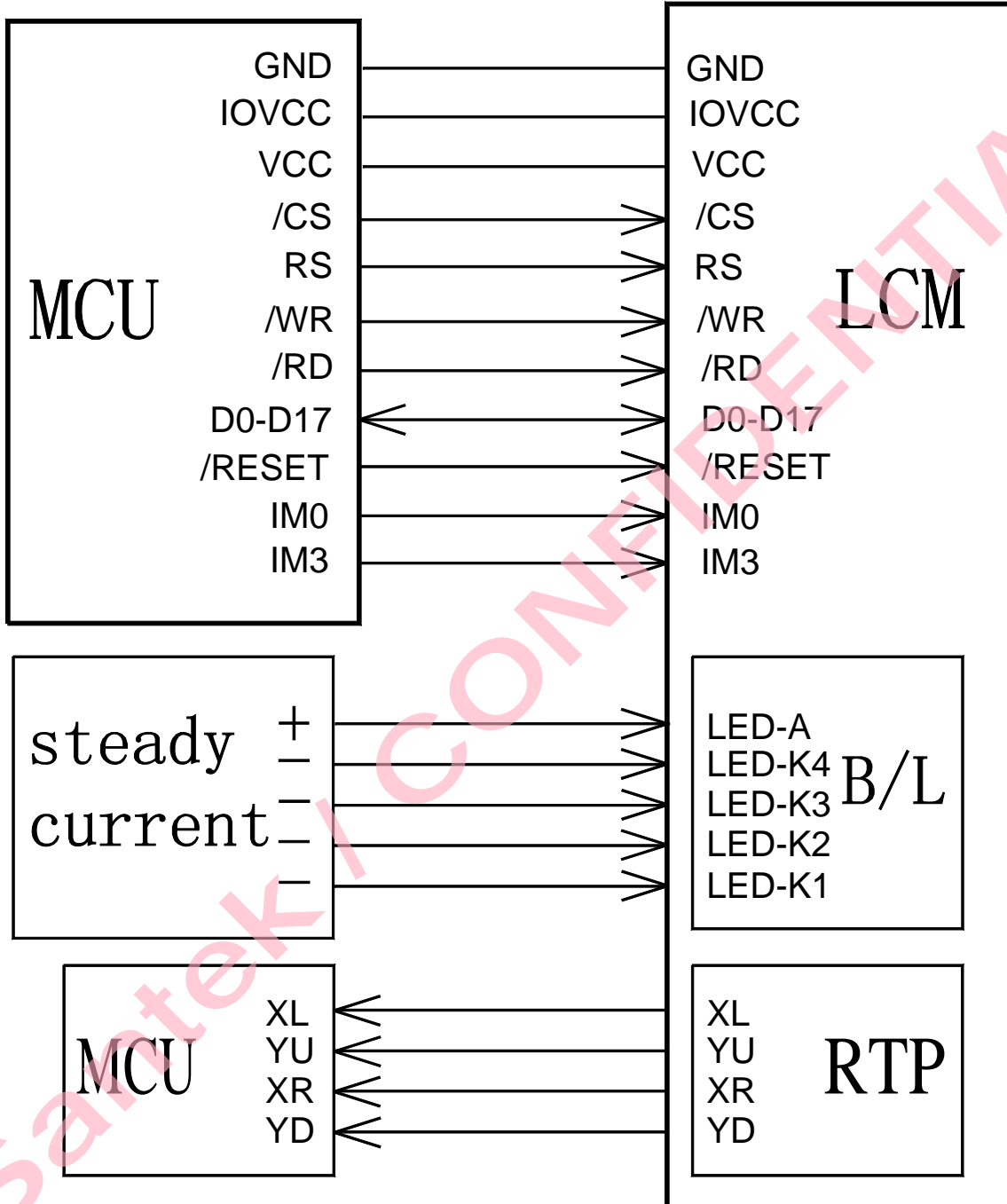

5.2. Absolute Maximum Ratings

Item	Symbol	Rating	Unit
Supply Voltage	VCC	- 0.3 ~ +4.6	V
Supply Voltage (Logic)	IOVCC	- 0.3 ~ +4.6	V
Driver Supply Voltage	VGH-VGL	-0.3 ~ +30.0	V
Logic Input Voltage Range	VIN	-0.3 ~ VDDI + 0.5	V
Logic Output Voltage Range	VO	-0.3 ~ VDDI + 0.5	V
Operating Temperature Range	TOPR	-20 ~ +70	°C
Storage Temperature Range	TSTG	-30 ~ +80	°C

Note: Permanent damage to the device may occur if maximum values are exceeded or reverse voltage is applied.

5.3. Typical Operation Condition

5.3.1 DC Characteristics

ITEM	SYMBOL	CONDITION	STANDARD VALUE			UNIT
			MIN	TYP	MAX	
Power Supply for Analog	VCC	Ta=25 °C	2.4	2.75	3.3	V
Power Supply for Digital IO	IOVCC	Ta=25 °C	1.65	1.8	3.3	V
Input Signal "H" Level	V _{IH}	-	0.7IOVCC	-	IOVCC	V
Input Signal "L" Level	V _{IL}	-	0	-	0.3IOVCC	V
Output Signal "H" Level	V _{OH}	I _{OH} =-0.1mA	0.8IOVCC	-	IOVCC	V
Output Signal "L" Level	V _{OL}	I _{OL} =0.1mA	0	-	0.2IOVCC	V

Note: To prevent IC latch up or DC operation in LCD panel, the power on/off sequence should follow the driver IC specification.

5.4. Backlight Specification

5.4.1 Backlight Circuit

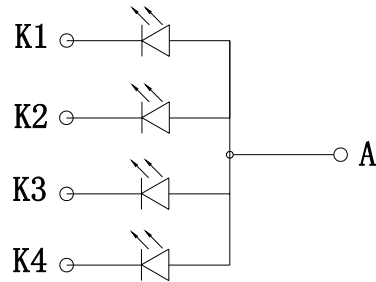

LED CIRCUIT DIAGRAM

5.4.2 Electrical Characteristics (T=25°C)

PARAMETER	SYMBOL	CONDITION	STANDARD VALUE			UNIT
			MIN	TYP	MAX	
FORWARD VOLTAGE (Single Chip)	VF	IF=80mA	2.8	3.2	3.4	V

5.5. INTERFACE TIMING CHARACTERISTICS

5.5.1 8080 Series MCU Parallel Interface Characteristics: 8/16-bit Bus

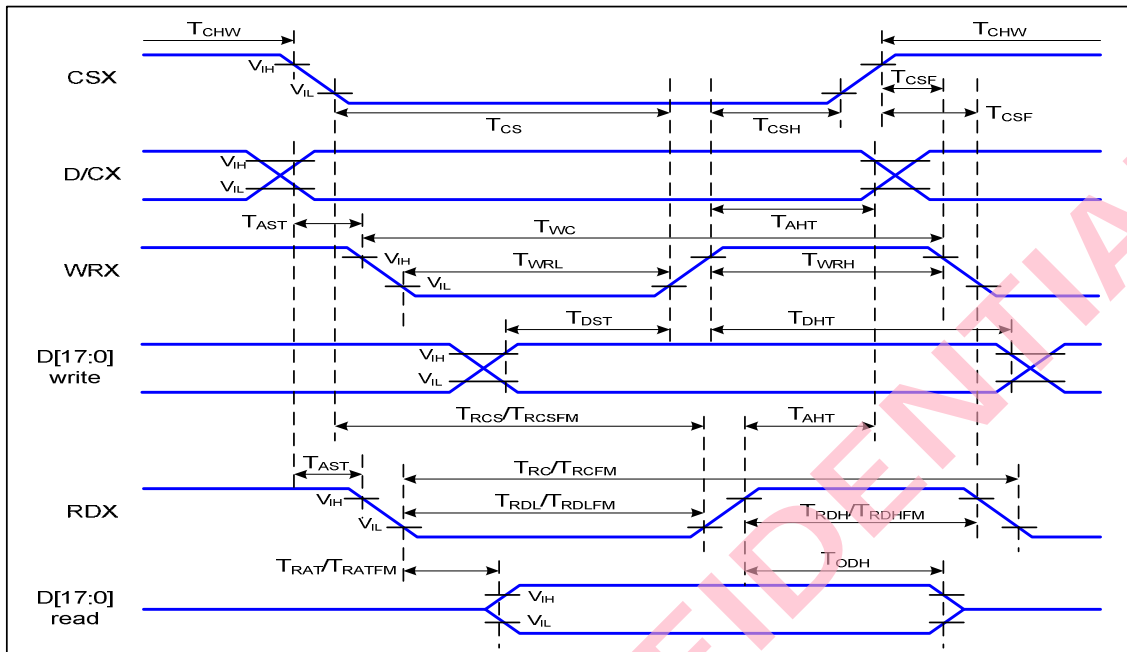

Signal	Symbol	Parameter	Min	Max	Unit	Description
D/CX	T_{AST}	Address setup time	0		ns	-
	T_{AHT}	Address hold time (Write/Read)	10		ns	-
CSX	T_{CHW}	Chip select "H" pulse width	0		ns	-
	T_{CS}	Chip select setup time (Write)	15		ns	-
	T_{RCS}	Chip select setup time (Read ID)	45		ns	-
	T_{RCSFM}	Chip select setup time (Read FM)	355		ns	-
	T_{CSF}	Chip select wait time (Write/Read)	10		ns	-
	T_{CSH}	Chip select hold time	10		ns	-
WRX	T_{WC}	Write cycle	66		ns	-
	T_{WRH}	Control pulse "H" duration	15		ns	-
	T_{WRL}	Control pulse "L" duration	15		ns	-
RDX (ID)	T_{RC}	Read cycle (ID)	160		ns	When read ID data
	T_{RDH}	Control pulse "H" duration (ID)	90		ns	
	T_{RDL}	Control pulse "L" duration (ID)	45		ns	
RDX (FM)	T_{RCFM}	Read cycle (FM)	450		ns	When read from frame memory
	T_{RDHFM}	Control pulse "H" duration (FM)	90		ns	
	T_{RDLFM}	Control pulse "L" duration (FM)	355		ns	
D[17:0]	T_{DST}	Data setup time	10		ns	For CL=30pF

6. TOUCH PANEL SPECIFICATION

- Product Type: Film+Glass
- Film: Clear and Hard Coating
- Operating Voltage: DC5V
- Operating force: 10~100g
- Insulation Resistance: $\geq 20M\Omega, 25V(DC)$
- Linearity: $\leq 1.5\%$
- Service Life: Notes Life: $\geq 20,000$
 Input Life: $\geq 1,000,000$
- Chatting Times: $< 10ms$
- Surface Hardness: $\geq 3H$
- Terminal Resistance: X: 100~500 Ω
 Y: 300~900 Ω
- All Materials is Complied with RoHS

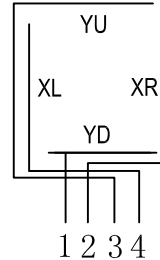

PIN	Logic
1	YD
2	XR
3	YU
4	XL

Santek | CONFIDENTIAL

7. OPTICAL CHARACTERISTICS

Item	Symbol	Condition	Values			Unit	Remark	
			Min.	Typ.	Max.			
Viewing Angle Range	Left	θ_L	CR \geq 10	35	45	-	degree	Note 1,2
	Right	θ_R		35	45	-		
	Top	Φ_T		35	45	-		
	Bottom	Φ_B		10	20	-		
Response Time	$T_{on} + T_{off}$	Normal $\theta = \Phi = 0^\circ$	-	30	-	ms	Note 2,3	
Contrast Ratio	CR	Normal $\theta = \Phi = 0^\circ$	300	500	-	-	Note 2,4	
Luminance	L	Normal $\theta = \Phi = 0^\circ$	280	350	-	cd/m ²	Note 2,5	
Color Chromaticity (CIE1931)	White	W_x	Normal $\theta = \Phi = 0^\circ$	0.2459	0.2959	0.3459	-	Note 2,6
		W_y		0.2792	0.3292	0.3792		
	Red	R_x		0.5246	0.5746	0.6246		
		R_y		0.2938	0.3438	0.3938		
	Green	G_x		0.2924	0.3424	0.3924		
		G_y		0.5663	0.6163	0.6663		
	Blue	B_x		0.0978	0.1478	0.1978		
		B_y		0.0157	0.0657	0.1157		
Color Gamut	NTSC	CIE1931	-	60	-	%	-	
Luminance Uniformity	U_L	Normal $\theta = \Phi = 0^\circ$	75	80	-	%	Note 2,7	

Note 1: Definition of viewing angle range

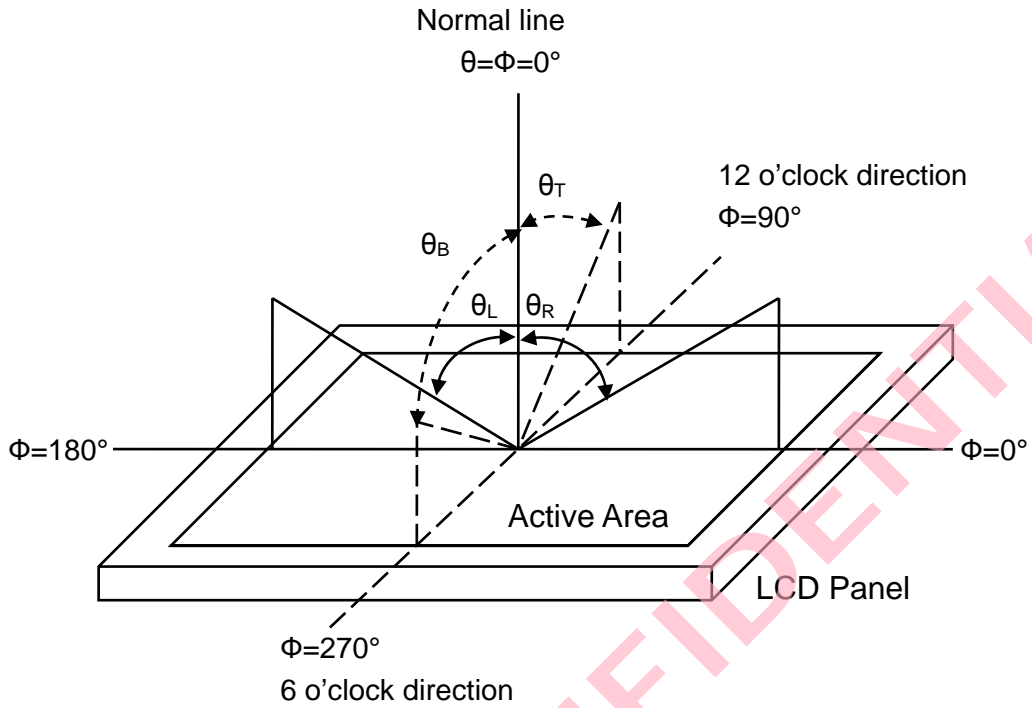

Fig. 1 Definition of viewing angle

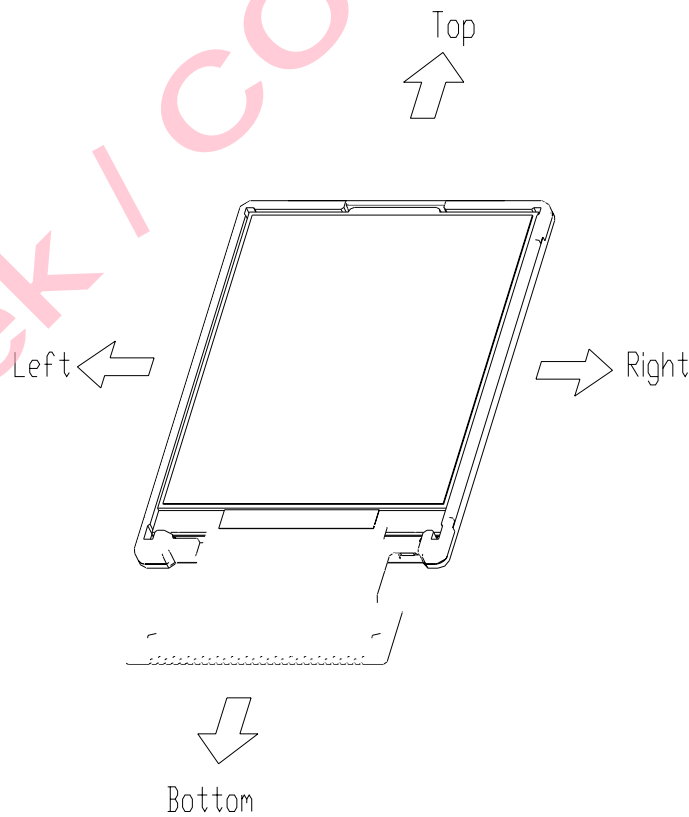

Fig. 2 Definition of viewing angle for display

Note 2: Definition of optical measurement system

The optical characteristics should be measured in a dark room with ambient temperature $T_a=+25^{\circ}\text{C}$. The optical properties are measured at the center point of the LCD screen after 5 minutes operation. (Equipment: Photo detector TOPCON BM-7 Field of view: 1° /Height: 500mm.)

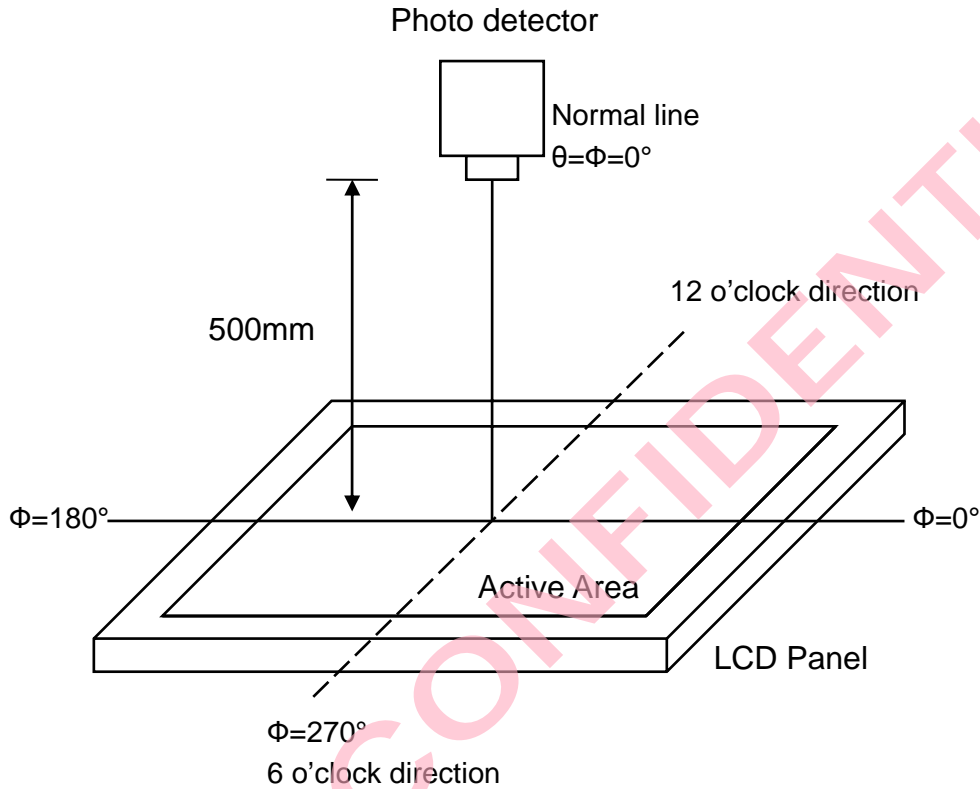

Fig. 3 Optical measurement system setup

Note 3: Definition of response time

The response time is defined as the LCD optical switching time interval between "White" state and "Black" state. Rise time (T_{on}) is the time between photo detector output intensity changed from 90% to 10%, and fall time (T_{off}) is the time between photo detector output intensity changed from 10% to 90%.

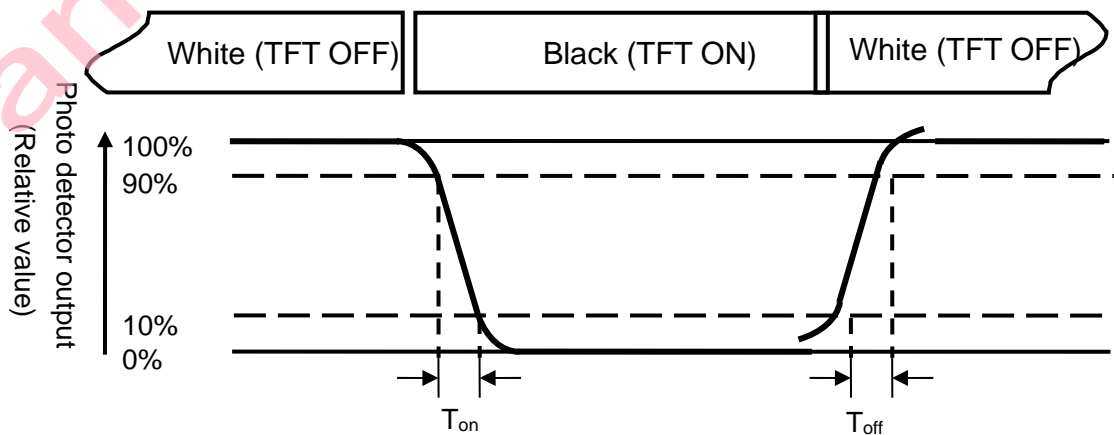

Fig. 4 Definition of response time

Note 4: Definition of contrast ratio

$$\text{Contrast ratio (CR)} = \frac{\text{Luminance measured when LCD on the "White" state}}{\text{Luminance measured when LCD on the "Black" state}}$$

Note 5: Definition of luminance

Measured at the center area of the panel when LCD panel is driven at “white” state.

Note 6: Definition of color chromaticity (CIE1931)

Color coordinates measured at the center point of LCD when panel is driven at “White”, “Red”, “Green” and “Blue” state respectively.

Note 7: Definition of luminance uniformity

To test for uniformity, the tested area is divided into 3 rows and 3 columns. The measurement spot is placed at the center of each circle as below.

$$\text{Luminance Uniformity (U}_L\text{)} = \frac{L_{\min}}{L_{\max}}$$

L-----Active area length W----- Active area width

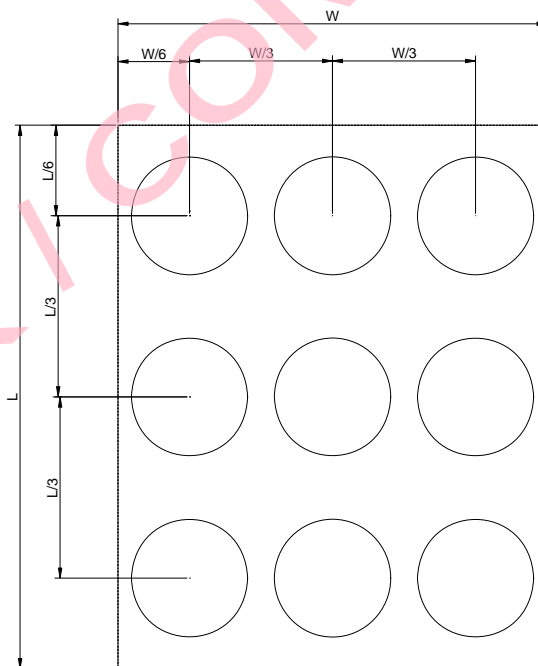

Fig. 5 Definition of luminance uniformity

L_{\min} : The measured minimum luminance of all measurement position.

L_{\max} : The measured maximum luminance of all measurement position.

8. RELIABILITY TESTS

ITEM	CONDITION	CRITERION
Operating Temperature Test	High Temperature: +70 °C, 120 hrs	No defects in display and operational functions
	Low Temperature: -20 °C, 120 hrs	
Storage Temperature Test	High Temperature: +80 °C, 120 hrs	No defects in display and operational functions
	Low Temperature: -30 °C, 120 hrs	
Humidity Endurance Test	60 °C±3°C, 90%±3%RH, 120 hrs	No defects in display and operational functions
Thermal Shock Test	-30 °C (30mins)~ +80 °C (30mins) 10 cycles	No defects in display and operational functions
Package Vibration Test	Random Vibration : Frequency:10~55Hz 1 hour for each direction of X. Y. Z. (3 hours for total)	No defects in display and operational functions
Package Drop Test	Height :72cm(Weight ≤ 10kg); 60cm(Weight ≥ 10kg) 1 corner, 3 edges, 6 surfaces	No defects in display and operational functions
Electro Static Discharge	± 2KV, Human Body Mode, 100pF/1500Ω	No defects in display and operational functions

NOTE:

- 1) The samples must be free from defect before test, must be restored at room condition at least for 2 hours after reliability test before any inspection.
- 2) Before test the function of TP, the sample must be placed in room temperature for 24hrs after RA test.
- 3) After a long period of high temperature, the surrounding edge of the LCM all-black image will appear MURA phenomenon, which is a normal phenomenon.

9. PRECAUTIONS

9.1. Handling

- 9.1.1. Polarizer Cleaning, Petroleum ether (or N-hexane) is recommended for cleaning the front/rear polarizers and reflectors, acetone, toluene and ethanol are not allowed.
- 9.1.2. Body grounding, must wear Anti-ESD wrist strap while pick up LCDs.
- 9.1.3. FPC Soldering, less than 300°C/3S, solder must be grounding on grounding bench.
- 9.1.4. If use electric Screwdriver to do assembly, screwdriver must be grounding.

9.2. Storage

- 9.2.1. Keep in a sealed polyethylene bag.
- 9.2.2. Keep in a dark place.
- 9.2.3. Keep in temperature between 0°C and 35°C.
NOT allowed at 70°C for more than 160 Hours, or at -20°C for more than 48 Hrs.

9.3. Safety

If liquid crystal leak out of a damaged glass cell, **DO NOT** put it in your mouth or touch eyes, if the liquid crystal touch your skin or clothes, please wash it off immediately using soap and water.

10. LIMITED WARRANTY

Unless otherwise agreed between Santek and customer, Santek will replace or repair any of its LCD modules which are found to be functionally defective when inspected in accordance with Santek LCD acceptance standards (copies available upon request) for a period of one year from date of shipments. Cosmetic/visual defects over specs must be returned to Santek within 30 days of shipment. Confirmation of such date shall be based on freight documents. The warranty liability of Santek limited to repair and/or replacement on the terms set forth replacement on the terms set forth above. Santek shall not be responsible for any subsequent or consequential events.

10.1. Returning LCM Under Warranty – Terms and Conditions

10.1.1. No warranty can be granted if the precautions stated above have been disregarded.

The typical examples of violations are :

- Broken LCD glass.
- Circuit modified in any way, including addition of components.

10.1.2. Module repairs will be invoiced to the customer upon mutual agreement. Modules must be returned with sufficient description of the failures or defects. Any connectors or cable installed by the customer must be removed completely without damaging the PCB's eyelet, conductors and terminals.