

3D VIEW

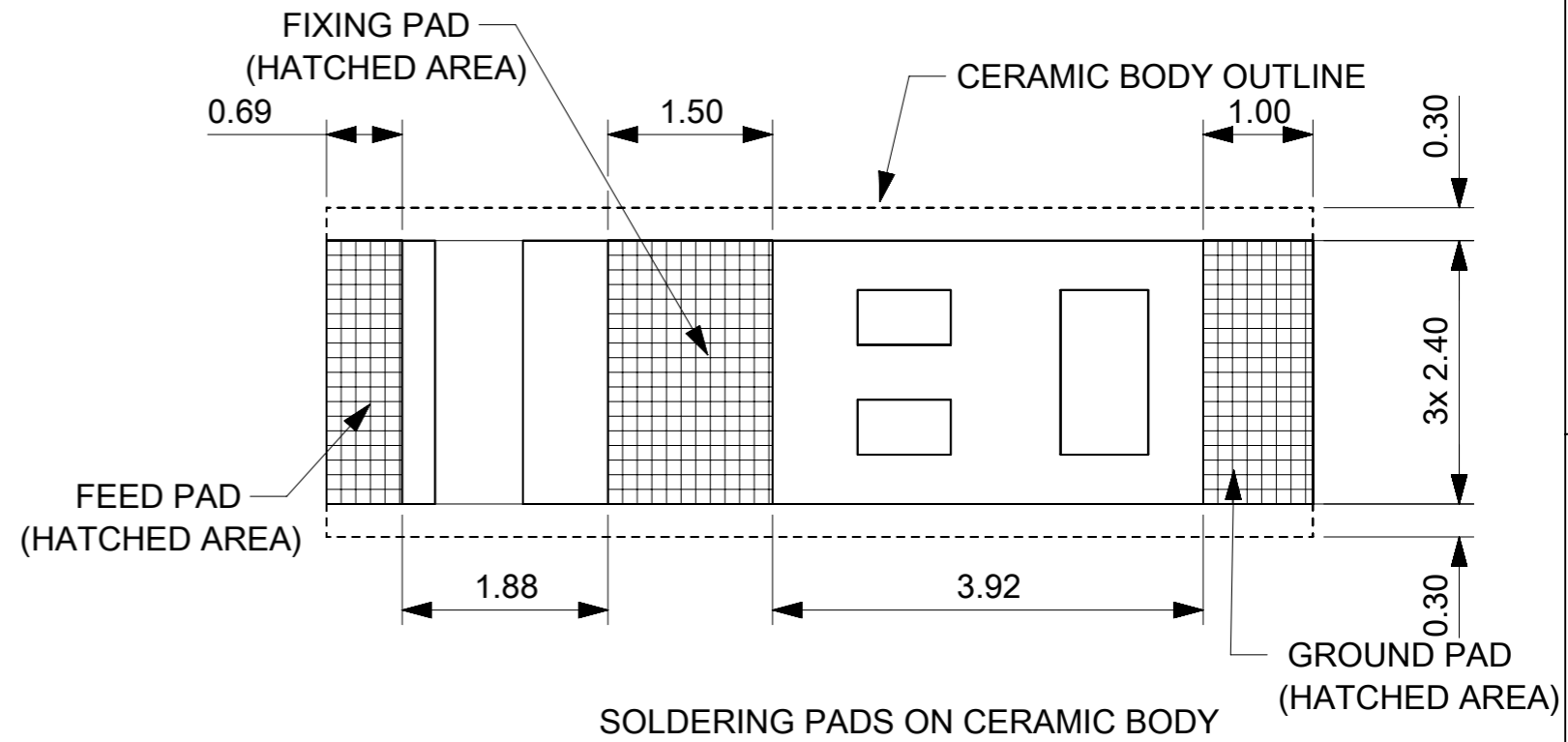

SPECIAL NOTE:
THERE IS NO ACTUAL SOLDERING PADS (HATCHED AREA ABOVE) ON ANTENNA BODY, CUSTOMER CAN USE OUR RECOMMENDED PRINT FOOT LAYOUT BELOW TO LIMIT OUR ANTENNA BODY ON THE VIRTUAL SOLDERING PADS AREA ABOVE.

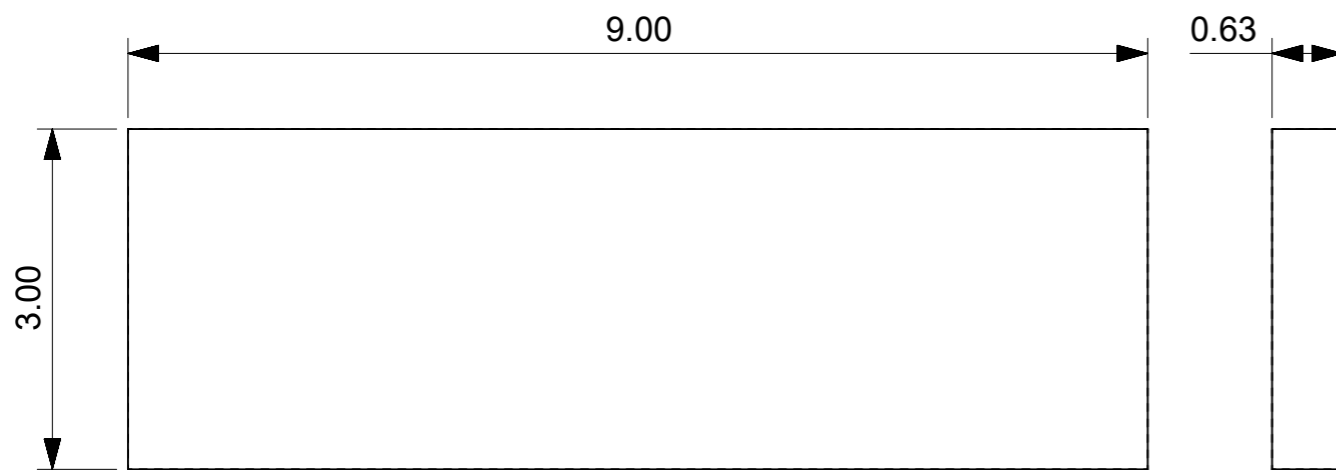
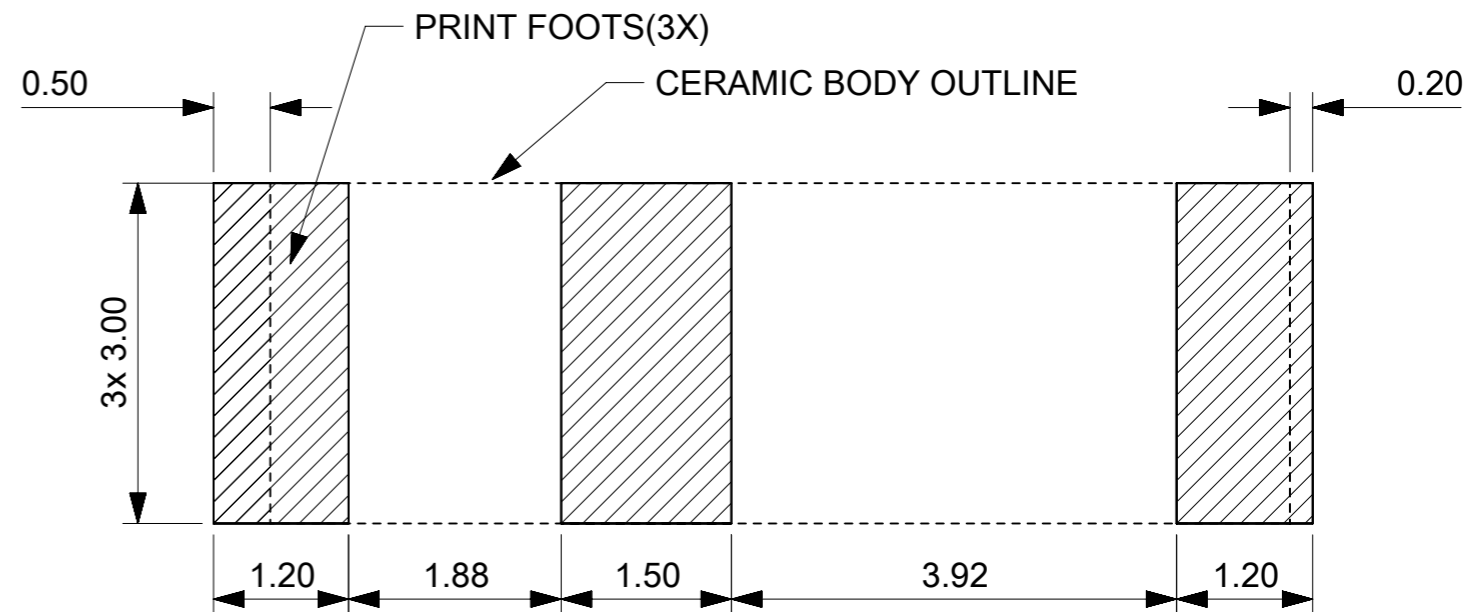

- NOTES:
1. MATERIAL: CERAMIC, P/N: 2081420001
 2. PATTERN: Ag PLATED, THICKNESS 3-7um
 3. PACKAGE SPEC. REFER TO PK OF 2081420001
 4. PRODUCT SPEC. REFER TO PS OF 2081420001
 5. APPLICATION SPEC. REFER TO AS OF 2081420001
 6. SUGGEST TO USE RED GLUE UNDER PART BEFORE SMT IF APPLICATION CONDITION IS STRICT

SYMBOLS	THIS DRAWING CONTAINS INFORMATION THAT IS PROPRIETARY TO MOLEX ELECTRONIC TECHNOLOGIES, LLC AND SHOULD NOT BE USED WITHOUT WRITTEN PERMISSION		CURRENT REV DESC:			molex				
	DIMENSION UNITS	SCALE							EC NO: 621927	DRWN: CZHOU05
▽ = 0	mm	20:1	DRWN: CZHOU05	2020/04/10		PRODUCT CUSTOMER DRAWING				
▽ = 0	GENERAL TOLERANCES (UNLESS SPECIFIED)		CHK'D: XJSONG	2020/04/10		DOCUMENT NUMBER				
▽ = 0	ANGULAR TOL ± °		APPR: XJSONG	2020/04/10		2081420001		DOC TYPE	DOC PART	REVISION
▽ = 0	4 PLACES ±		INITIAL REVISION:							
▽ = 0	3 PLACES ±		DRWN: CZHOU05		2018/10/31					
▽ = 0	2 PLACES ±		APPR: XJSONG		2018/11/09					
▽ = 0	1 PLACE ±		APPR: XJSONG							
▽ = 0	0 PLACES ±		DRAFT WHERE APPLICABLE MUST REMAIN WITHIN DIMENSIONS							
▽ = 0	THIRD ANGLE PROJECTION		DRAWING		SERIES	MATERIAL NUMBER		CUSTOMER		SHEET NUMBER
▽ = 0	A3-SIZE		208142							1 OF 1