

Order Number
63808-3600

molex

Application Tooling Specification

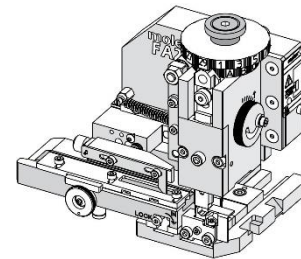

FEATURES

- Applicator designed to industry-standard mounting and 135.80mm (5.346") shut height
- Quick setup time; plus, the crimp height, track and feed adjustments can be set without removing the applicator from the press
- Fine adjustment allows users to achieve target with little effort by adjusting in increments of 0.015mm (.0006") for conductor crimp height and 0.025mm (.001") for insulation height
- Independent adjustment rings allow users to quickly adjust the conductor or insulation crimp height without affecting each other
- Directly adapts to most automatic wire processing machines
- This applicator was designed for use in a wire processor only
- Fine adjustment of the bend is achieved using the bend adjust dial

SCOPE

Products: CTX150 Receptacle S Grip Terminals, 0.50mm² Wire.

Terminal Series No.	Terminal Order No.	Wire		Insulation Diameter		Strip Length	
		Wire Type	Size	mm	In.	mm	In.
502307	502307-0111	T3-ZHID	0.50mm ²	1.25-1.70	.049-.067	4.50-5.00	.177-.197
		AVSS					
	502307-0411	T3-ZHID					
		FLRY-A					
34805	34805-0111	T3-ZHID					
		AVSS					
	34805-0411	T3-ZHID					
		FLRY-A					
34864	34864-0111	T3-ZHID					
		AVSS					
	34864-0411	T3-ZHID					
		FLRY-A					

CAUTION: This applicator was designed for use in a wire processor only.

DEFINITION OF TERMS

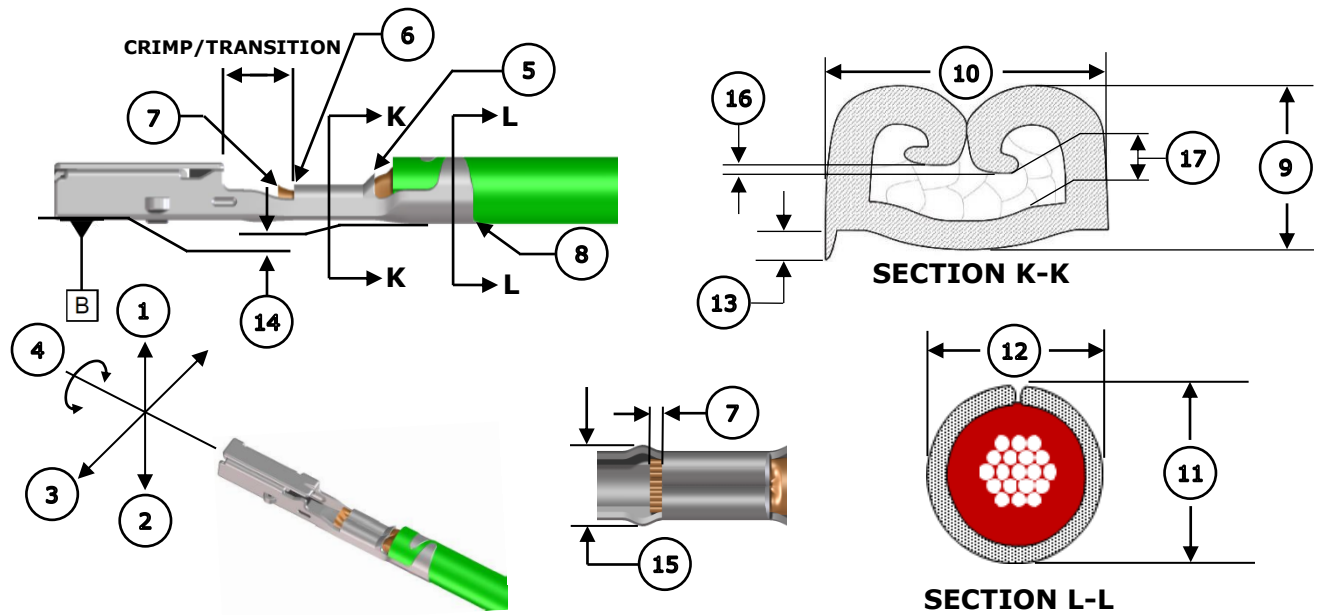

CRIMP SPECIFICATIONS

The following crimp specifications are based on document AS-502307-001 Rev. E:

Feature	Requirement
1. Bend Up	1.5° Max
2. Bend Down	1.5° Max
3. Twist	4° Max
4. Roll	6° Max
5. Bell Mouth Rear	0.20-0.55mm (.008-.022") for Wire Types T3-ZHID and AVSS 0.20-0.65mm (.008-.026") for Wire Type FLRY-A
6. Bell Mouth Front	Not Applicable
7. Conductor Brush	0.20-1.20mm (.008-.047")
8. Cut-Off Tab	0.30mm (.012") Max
Conductor Crimp	Wire Type Wire Size 9. Crimp Height 10. Crimp Width
	AVSS 0.50mm ² 0.85-0.95mm .033-.037 in. 1.55-1.65mm .061-.065 in.
	T3-ZHID 0.50mm ² 0.80-0.90mm .031-.035 in. 1.55-1.65mm .061-.065 in.
	FLRY-A 0.50mm ² 0.75-0.81mm .030-.032 in. 1.55-1.65mm .061-.065 in.
Insulation Crimp	Wire Type Wire Size 11. Crimp Height 12. Crimp Width
	AVSS 0.50mm ² 1.90-2.10mm .075-.083 in. 1.75-1.95mm .069-.077 in.
	T3-ZHID 0.50mm ² 1.80-2.00mm .071-.079 in. 1.75-1.95mm .069-.077 in.
	FLRY-A 0.50mm ² 1.90-2.10mm .075-.083 in. 1.75-1.95mm .069-.077 in.
Pull Force	Wire Type Wire Size Minimum Force
	AVSS 0.50mm ² 90 N 20.20 lb.
	T3-ZHID 0.50mm ² 80 N 18.00 lb.
	FLRY-A 0.50mm ² 50N 11.20 lb.
13. Conductor Anvil Flash	0.125mm (.005") Max
14. Insulation Grip Step	0.00-0.30mm (.000-.012") Below Datum B
15. Crimp Bulge	2.24mm (.088") Max within crimp/transition area
16. Wing Dissymmetry	0.25mm (.010") Max
17. Space Between Wing Tips and Crimp Bottom	0.125mm (.005") Min

NOTES

Applicator Notes

- This applicator is for automatic wire processor use only.
- This applicator does not include a cutting insert.
- Installing a cutting insert will cause jamming in this applicator.

CUTTING INSERT

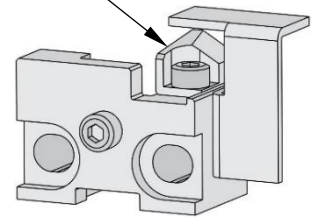

Specification Notes

- This applicator should only be run in a properly set up wire processor to consistently achieve the brush length

General Notes

1. Molex recommends that an extra perishable tooling kit be maintained at your facility.
2. Verify tooling alignment by hand cycling the press and applicator before crimping under power. Check that all screws are tight.
3. Slugs, terminals, dirt and oil should be kept clear of the work area.
4. Wear safety glasses at all times.
5. For recommended maintenance, refer to the FA2 manual (TM-638080200).
6. Molex recommends crimping stranded copper wire only.

WARNINGS

CAUTION: This applicator must be installed in a press with a standard shut height of 135.80mm (5.346"). Tooling damage could result at a lower setting.

CAUTION: To prevent injury, never operate this applicator without the guards supplied with the press or wire-processing machine in place. Reference the press or wire processing manufacturer's instruction manual.

CAUTION: Molex tooling crimp specifications are valid only when used with Molex terminals and tooling manufactured by Molex and sold by Molex or authorized distributors ("Molex Tooling"). When using tooling other than Molex Tooling with Molex-specific connector systems listed in our ATS documents, the Molex Tooling qualification does not apply, and the responsibility for full qualification of the connector system is that of the customer. Molex accepts no liability for connector performance or tooling support where tooling other than Molex Tooling is used or where Molex Tooling is modified.

PARTS LIST

Applicator 63808-3600				
Item	Order No.	Engineering No.	Description	Quantity
Perishable Tooling				
	63808-3670	63808-3670	Tool Kit (All "Y" Items)	Ref
1	63454-1806	63454-1806	Insulation Punch	1 Y
2	200216-1604	200216-1604	Conductor Punch	1 Y
3	63456-1804	63456-1804	Insulation Anvil	1 Y
4	63455-1604	63455-1604	Conductor Anvil	1 Y
5	63443-0121	63443-0121	Cut-Off Plunger	1 Y
Non-Perishable Components				
6	63443-0118	63443-0118	Front Plunger Retainer	1
7	01124-1067	4996-4	Cut-Off Plunger Spring	1
8	63443-0117	63443-0117	Front Scrap Chute	1
9	63443-7511	63443-7511	Anvil Mount	1
10	63443-0090	63443-0090	Wire Stop Assembly	1
11	63443-3603	63443-3603	Front Plunger Striker	1
12	63443-3702	63443-3702	Wire Hold Down Plunger	1
13	63600-5776	63600-5776	Nose Hold Down	1
14	63600-5775	63600-5775	Nose Hold Down Shank	1
15	63808-0220	63808-0220	Nose Hold Down Block	1
16	63443-4716	63443-4716	Terminal Guide	1
17	63443-4404	63443-4404	Feed Cam	1
18	63808-0229	63808-0229	Bend Adjust Dial	1
Frame				
19	63808-0200	63808-0200	Applicator Core	1
20	63808-0197	63808-0197	Mechanical Feed Assembly	1
21	63808-0191	63808-0191	Track Assembly	1
Hardware				
22	—	—	M2.5 x 4 SHCS	1*
23	—	—	M3 Hex Nut	1*
24	—	—	M3 Flat Washer Hard	1*
25	—	—	M3 Inner Tooth Lock Washer	1*
26	—	—	M3 x 3 SSS	2*
27	—	—	M3 x 6 BHCS	2*
28	—	—	M3 x 12 SHCS	4*
29	—	—	M4 x 5 SSS	1*
30	—	—	M4 x 6 SHCS	1*
31	—	—	M4 x 8 SHCS	2*
32	—	—	M4 x 45 SHCS	2*
33	—	—	M5 x 12 SHCS	1*
34	—	—	M5 x 10 Long Cup Point SSS	1*
35	—	—	M5 Hex Jam Nut	1*
*Fastener parts can be purchased through most industrial suppliers by using the description in the table above.				

ASSEMBLY DRAWING

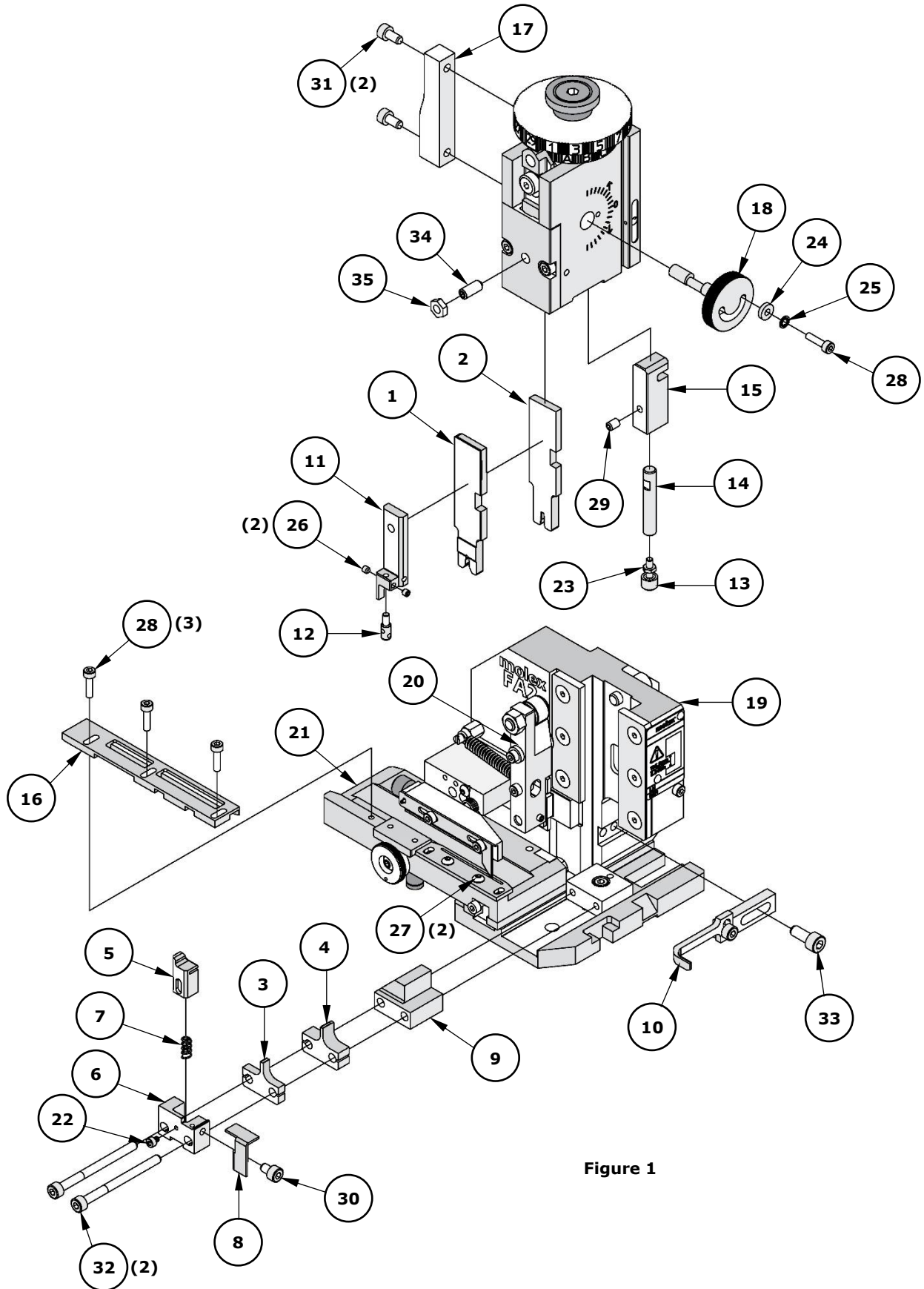

Figure 1

FACTORY SETTINGS

Feed Pawl Assembly

The FA2 applicator number 63808-3600 ships with the following factory settings. See Figure 2:

- The feed pawl shaft and M3 screw that holds the feed pawl spring are in position 3.
- The pin is in position B.

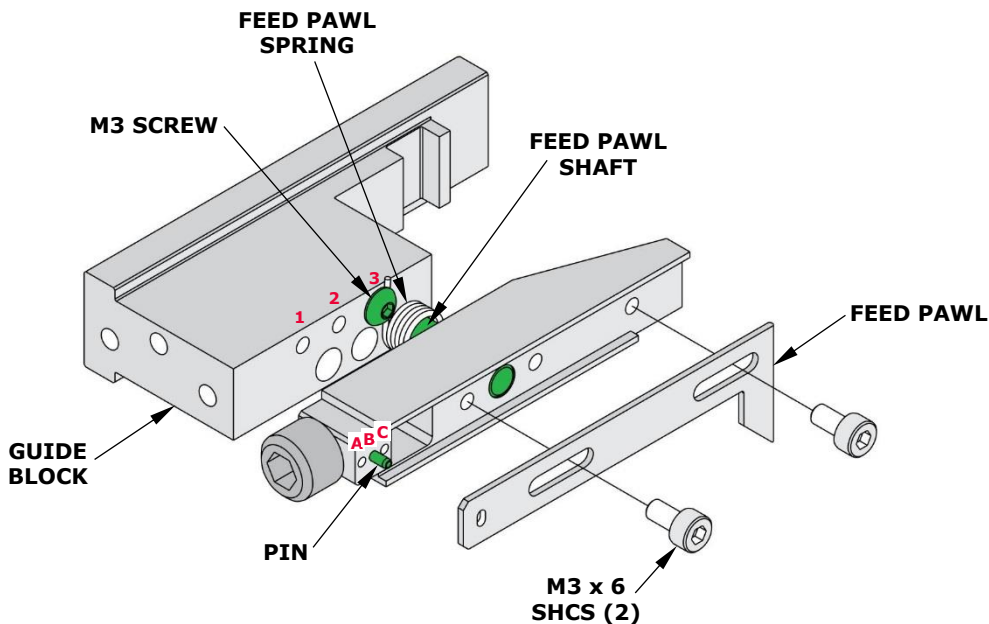
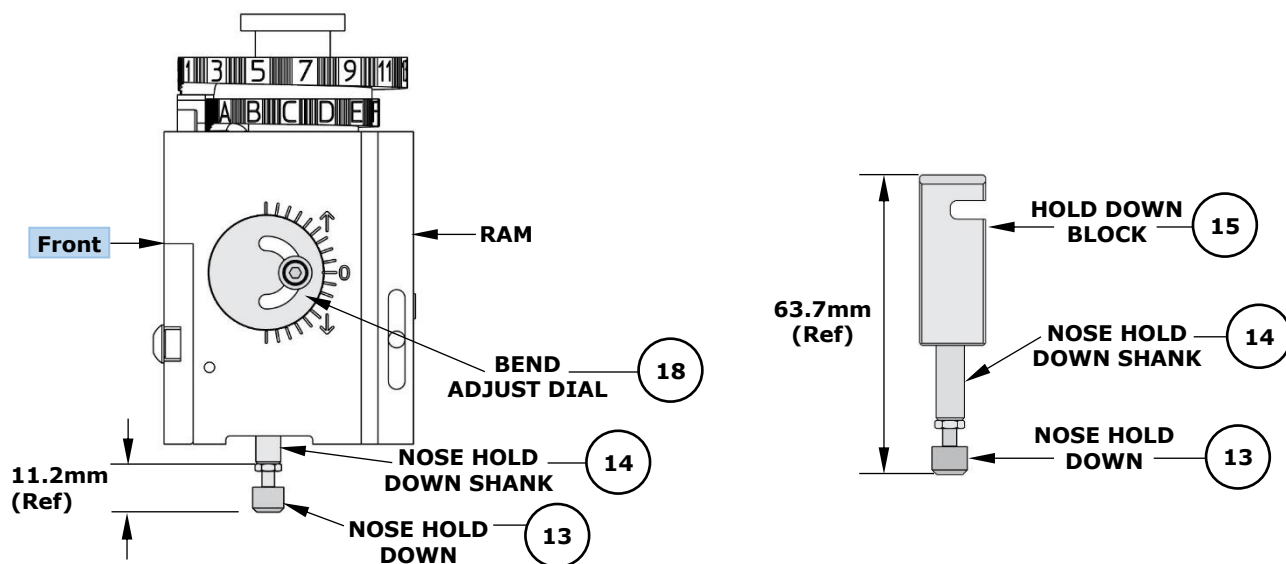

Figure 2

Note: Each applicator is configured and tested by Molex prior to shipping, and the above settings were used to produce the included sample crimps.

Third Dial/Ram Assembly

○ Indicates item number on the Parts List and Assembly Drawing



Note: The above dimensions were measured during setup and are included as a reference only. Additional adjustments may be required before crimping for production.

Mounting Datum Location

This applicator was assembled and tested by Molex with the mounting datum in the location shown in Figure 4. Do not remove the mounting datum.

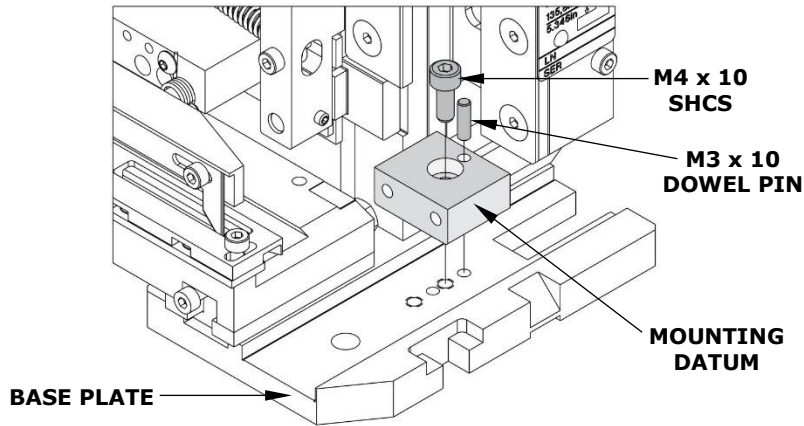

Figure 4

Application Tooling Support

Phone: (402) 458-TOOL (8665)
E-Mail: toolingsupport@molex.com
Website: www.molex.com/applicationtooling

Molex is a registered trademark of Molex, LLC in the United States of America and may be registered in other countries; all other trademarks listed herein belong to their respective owners.