

Customer Information Sheet

DRAWING No.: M80-19500XX

IF IN DOUBT - ASK

©

NOT TO SCALE

THIRD ANGLE PROJECTION

ALL DIMENSIONS IN mm

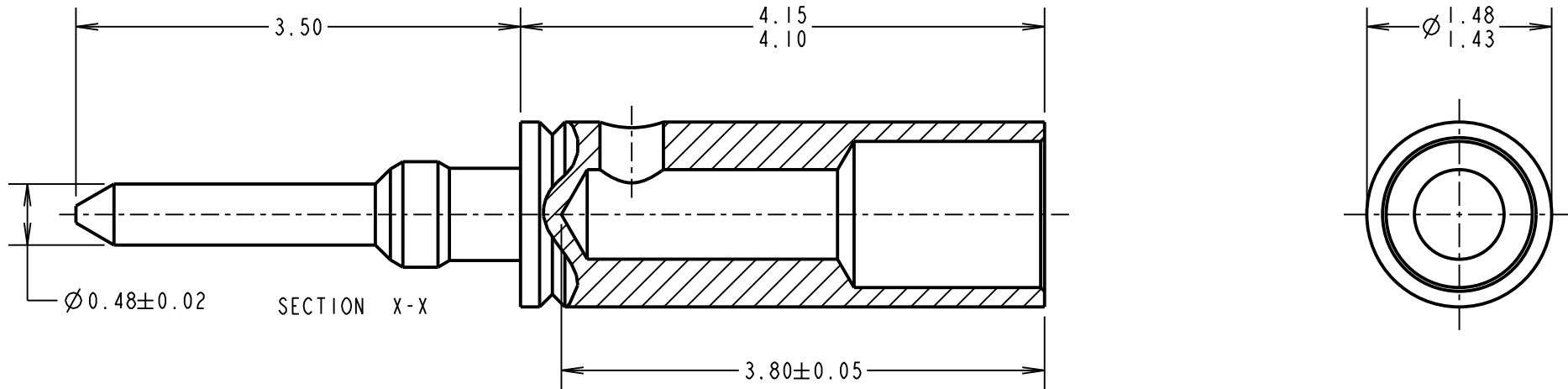

NOTES:

- SUITABLE FOR WIRE GAUGE 24-28 AWG. MAXIMUM INSULATION DIAMETER Ø1.10mm, BS 3G 210 TYPE A WIRE RECOMMENDED. STRIP WIRE BY 2.00mm FOR CRIMPING.
- RECOMMENDED CRIMP TOOL = M22520/2-01, POSITIONER = Z80-193
- FOR INSTRUCTIONS ON HAND CRIMP TOOL M22520/2-01, SEE INSTRUCTION SHEET IS-01.
- SUITABLE FOR USE IN MALE CRIMP JACKSCREW DATAMATE MOULDINGS.

SPECIFICATION:

MATERIAL:

CONTACT SHELL = BRASS

FINISH:

05 = 0.25-0.30µm GOLD OVER NICKEL

MECHANICAL:

DURABILITY = 500 OPERATIONS

ENVIRONMENTAL:

OPERATING TEMPERATURE = -55°C TO +125°C

PACKING:

BULK

FOR COMPLETE CONNECTOR SPECIFICATION, SEE COMPONENT SPECIFICATION C005XX (LATEST ISSUE)

ORDER CODE:

M80-1950005

FINISH _____

05 - 0.25-0.30µm GOLD

RA	9	28.07.20	21871
NAME	ISS.	DATE	CN/CO
APPROVED:		R.ALEXANDER	
CHECKED:		R.PORTLOCK	
DRAWN:		W. J. BOURNE	
CUSTOMER REF.:			
ASSEMBLY DRG:			

HARWIN

www.harwin.com
technical@harwin.com

THIS DRAWING AND ANY INFORMATION OR DESCRIPTIVE MATTER SET OUT HEREON ARE CONFIDENTIAL AND COPYRIGHT PROPERTY OF THE HARWIN GROUP AND MUST NOT BE DISCLOSED, LOANED, COPIED OR USED FOR MANUFACTURING, TENDERING OR FOR ANY OTHER PURPOSE WITHOUT THEIR WRITTEN PERMISSION.

TOLERANCES

X. = ±1mm
X.X = ±0.50mm
X.XX = ±0.20mm
X.XXX = ±0.01mm
ANGLES = ±5°
UNLESS STATED

MATERIAL:

BRASS

FINISH: SEE ORDER CODE

S/AREA: mm²

TITLE:

JACKSCREW DATAMATE
MALE CRIMP CONTACT
(SMALL BORE)

DRAWING NUMBER:

M80-1950005

SHT
2 OF 2