

PART NUMBER	REVISION	DESCRIPTION	FEED TYPE
2151929-1	F	FINE CRIMP HEIGHT ADJUST	MECHANICAL
2151929-2	F	FINE CRIMP HEIGHT ADJUST	PNEUMATIC
7-2151929-1	F	MECHANICAL AND CRIMP TOOLING KIT	MECHANICAL
7-2151929-2	F	PNEUMATIC AND CRIMP TOOLING KIT	PNEUMATIC
7-2151929-7	A	CRIMP TOOLING KIT	-

ATLANTIC VERSION TERMINATOR INTERFACE ADAPTER

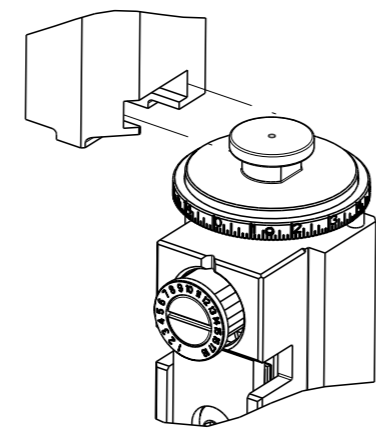

APPLICATOR DATA		
CRIMP	SIZE	TYPE
WIRE	1.40 mm [.055]	F
INSUL	1.60 mm [.063]	F

APPLICATOR INSTRUCTIONS
408-35042

TERMINAL DATA: MOLEX TERMINAL		MOLEX CRIMP SPECIFICATION	
TERMINAL NAME: MICRO-FIT (3.0) FEMALE CRIMP TERMINAL			
WIRE STRIP LENGTH		INSULATION DIAMETER RANGE	
2.54-2.92 mm [.100-.115 IN]		Ø1.10-1.30 mm [.043-.051 IN]	5
TERMINAL APPLICATION SPECIFICATION 63901-8800 Rev C			

TERMINALS APPLIED			
TE TERMINAL	MOLEX TERMINAL	TE TERMINAL	MOLEX TERMINAL
286747-1	43030-0003	286974-2	43031-0002
286747-2	43030-0002	286974-3	43031-0003
286747-3	43030-0001	286974-4	43031-0017
286747-4	43030-1001	286974-5	43031-0018
286747-5	43030-0051	286974-6	43031-0051
286747-6	43030-0052	286974-7	43031-0052
286747-7	43030-0053	286974-8	43031-0053
286747-8	45773-0001	286974-9	43031-0102
286747-9	45773-0002	1-286974-0	43031-0103
1-286747-0	45773-0003	1572840-1	44372-0002
1-286747-1	45773-0053	1572840-2	44372-3606
286974-1	43031-0001		

WIRE SIZE	CRIMP HEIGHT mm [INCH]	CRIMP HEIGHT REFERENCE SETTING
20 AWG OR 0.50mm2	0.95+/-0.04 [.0375+/-0.0015]	8.3
22 AWG OR 0.35mm2	0.875+/-0.035 [.0345+/-0.0015]	9.1
24 AWG OR 0.20mm2	0.815+/-0.035 [.032+/-0.001]	9.8

- 1 RECOMMENDED SPARE PARTS
- 2 REFER TO SUPPLIED INSTRUCTION SHEET FOR CLEANING, LUBRICATION AND STORAGE OF APPLICATOR.
- 3 APPLY PART NUMBER 2-23419-6 LOCTITE TO THREADS OF ITEM 242.
- 4 CRIMP HEIGHT REFERENCE SETTING WAS THE SETTING USED WHEN THE APPLICATOR WAS QUALIFIED AT THE FACTORY. ADJUSTMENT MAY BE NECESSARY WHEN RUNNING APPLICATOR IN THE FIELD.
- 5 THIS APPLICATOR IS FOR INSULATION RANGE 1.10-1.30. REFER TO APPLICATOR 2151941 FOR INSULATION RANGE 2.31-2.77. REFER TO APPLICATOR 2151375 FOR INSULATION RANGE 1.30-1.85.
- 6. UNLESS SPECIFIED OTHERWISE TORQUE VALUES SHALL BE USED PER DOCUMENT, 101-35000.

TERMINAL DATA: ANDERSON TERMINAL		MOLEX CRIMP SPECIFICATION	
TERMINAL NAME: MICRO-FIT (3.0) FEMALE CRIMP TERMINAL			
WIRE STRIP LENGTH		INSULATION DIAMETER RANGE	
2.54-2.92 mm [.100-.115 IN]		Ø1.10-1.30 mm [.043-.051 IN]	5
TERMINAL APPLICATION SPECIFICATION 63901-8800 Rev C			

TERMINALS APPLIED			
TE TERMINAL	ANDERSON TERMINAL	TE TERMINAL	ANDERSON TERMINAL
1-286747-2	4202G1	1-286974-1	4203G1
1-286747-3	4202G3	1-286974-2	4203G3

***WARNING**
ON INSTALLATION, SET WIRE DISC TO CRIMP HEIGHT REFERENCE SETTING FOR LARGEST WIRE SIZE. CRIMP HEIGHT REFERENCE SETTINGS GREATER THAN THE VALUE SHOWN MAY CAUSE DAMAGE TO THE CRIMP TOOLING, REFER TO THE INSTRUCTION SHEET FOR PROPER SETUP AND ADJUSTMENTS.

ATLANTIC VERSION
Shown on sheets 1 of 4 & 2 of 4
(Pacific version shown on sheets 3 of 4 & 4 of 4)

LOC	DIST	REVISIONS			
A	66	REV	DATE	BY	APPV
C	ECR-19-006253	17APR2019	TB	GB	
D	ECR-19-016470	22OCT2019	TB	TE	
E	ECR-20-016023	10NOV2020	JWC	RK	
F	ECR-20-017418	08DEC2020	JWC	GB	

-	1	-	1	-	2119641-1	FEED CAM, AIR FEED	248
-	1	1	1	1	2119082-9	CAM, SNAIL, INSULATION ADJUSTMENT	244
-	1	1	1	1	2079764-1	WASHER, WAVE SPRING, CREST-TO-CREST	243
-	1	1	1	1	2119083-1	RETAINER, INSULATION DIAL	242
-	1	1	1	1	7-18023-7	SCR, SKT HD CAP M3 X 4.0	241
-	-	1	-	1	2119580-1	MECHANICAL FEED ASSEMBLY	239
-	1	-	1	-	2844940-1	AIR FEED MODULE	238
-	REF	REF	REF	REF	994970-2	COUNTER, MAGNETIC	164
-	1	1	1	1	1-18028-2	WASHER, FLAT, REG M4	119
-	1	1	1	1	2844908-1	SCREW, LOCKING	99
-	1	1	1	1	2844907-1	POST, LOCKING	98
-	1	1	1	1	455888-6	SPACER, CRIMPER	82
-	1	1	1	1	1803607-3	DOCUMENTATION PACKAGE	71
-	1	1	1	1	2119740-1	TAG, IDENTIFICATION	67
-	2	2	2	2	2168078-1	SCREW, DRIVE, RH, RoHS, 2 x .188	66
-	1	1	1	1	2168083-2	SCR, SKT HD CAP, RoHS, M4 X 8.0	60
-	1	1	1	1	5-18022-5	SCR, HEX HD CAP, M4 X 6.0	59
-	1	1	1	1	1338685-1	PAWL, FEED	56
-	4	4	4	4	2168083-3	SCR, SKT HD CAP, RoHS, M4 X 12.0	54
-	2	2	2	2	2168083-3	SCR, SKT HD CAP, RoHS, M4 X 12.0	53
-	1	1	1	1	5018030-1	NUT, HEX, REG, RoHS, M3	52
-	1	1	1	1	811242-5	BUMPER, HOLD DOWN	51
-	1	1	1	1	690753-2	SPACER, TONKER	50
-	1	2	1	2	18023-9	SCR, SKT HD CAP M4 X 6.0	49
-	-	1	-	1	2119652-1	FEED CAM, PRE FEED	48
-	-	1	-	1	2119653-1	FEED CAM, POST FEED	47
-	1	1	1	1	1803583-9	APPLICATOR BASIC ASSEMBLY, SF	46
-	1	1	1	1	1803515-1	RAM ASSEMBLY, SF ATLANTIC	44
-	1	1	1	1	1803602-1	SCR, BHSC, RoHS (M8 X 25)	41
-	1	1	1	1	1752356-3	SUPPORT, TERMINAL	34
-	2	2	2	2	2079383-5	SCR, BHSC, RoHS (M4 X 20)	33
-	2	2	2	2	2-2844962-4	SPACER, CYLINDRICAL, STRIP GUIDE	30
-	1	1	1	1	2844992-1	ASSEMBLY, STRIP GUIDE	29
-	1	1	1	1	1-455888-0	SPACER, CRIMPER	28
-	1	1	1	1	1320928-2	STRIP GUIDE	24
-	1	1	1	1	2168083-2	SCR, SKT HD CAP, RoHS, M4 X 8.0	21
-	1	1	1	1	1-18028-2	WASHER, FLAT, REG M4	20
-	1	1	1	1	2119533-1	STRIPPER, SIDE FEED	19
-	1	1	1	1	2119806-1	INSERT, SHEAR	13
-	1	1	1	1	3-22280-3	SPRING, COMPRESSION	12
-	1	1	1	1	1-356885-4	STOP, SHEAR	11
-	1	1	1	1	2119805-1	SHEAR HOLDER, FRONT	10
-	1	1	1	1	1803095-1	FLOATING SHEAR, FRONT	9
-	1	2	2	1	1-1633917-6	ANVIL, COMBINATION	8
-	1	1	1	1	3-240641-9	SPACER	7
-	-	-	-	-	-	-	6
-	1	1	1	1	2119757-8	DEPRESSOR, SHEAR	5
-	1	1	1	1	5-238011-3	BLOCK, CRIMPER SPACER	4
-	1	2	2	1	7-2119582-6	CRIMPER, INSULATION F PREMIUM	3
-	1	1	1	1	455888-3	SPACER, CRIMPER	2
-	1	2	2	1	1-456402-5	CRIMPER, WIRE PREMIUM	1

DIMENSIONS:		TOLERANCES UNLESS OTHERWISE SPECIFIED:		OWN	CHK	DATE	NAME
mm	0 PLC ±	1 PLC ±	2 PLC ±	HOFFNER	T. ELBIN	19APR2013	TE Connectivity
	3 PLC ±	4 PLC ±	ANGLES ±	HOFFNER	T. ELBIN	22APR2013	Harrisburg, PA 17105-3608
MATERIAL	FINISH	WEIGHT	SCALE	Customer Accessible Production Drawing		SHEET 1 OF 4	REV F

LOC		DIST		REVISIONS			
A	66	P	LYR	DESCRIPTION	DATE	OWN	APVD
		-		SEE SHEET 1	-	-	-

FEED TYPE MECHANICAL

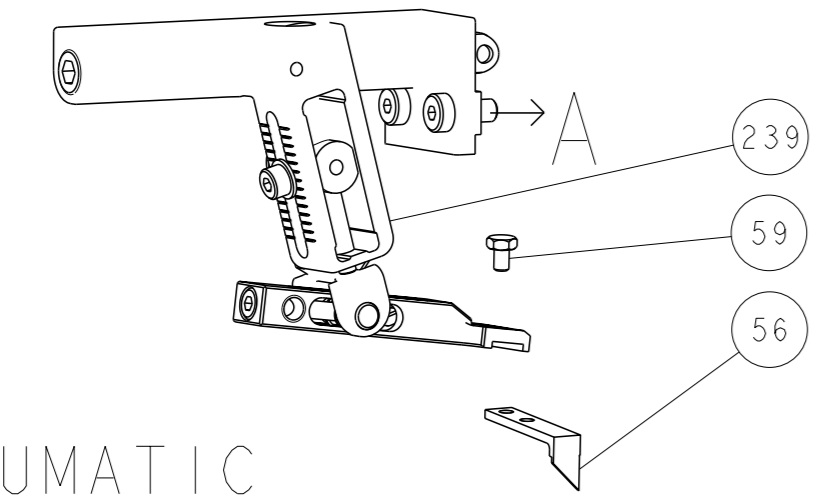

PNEUMATIC

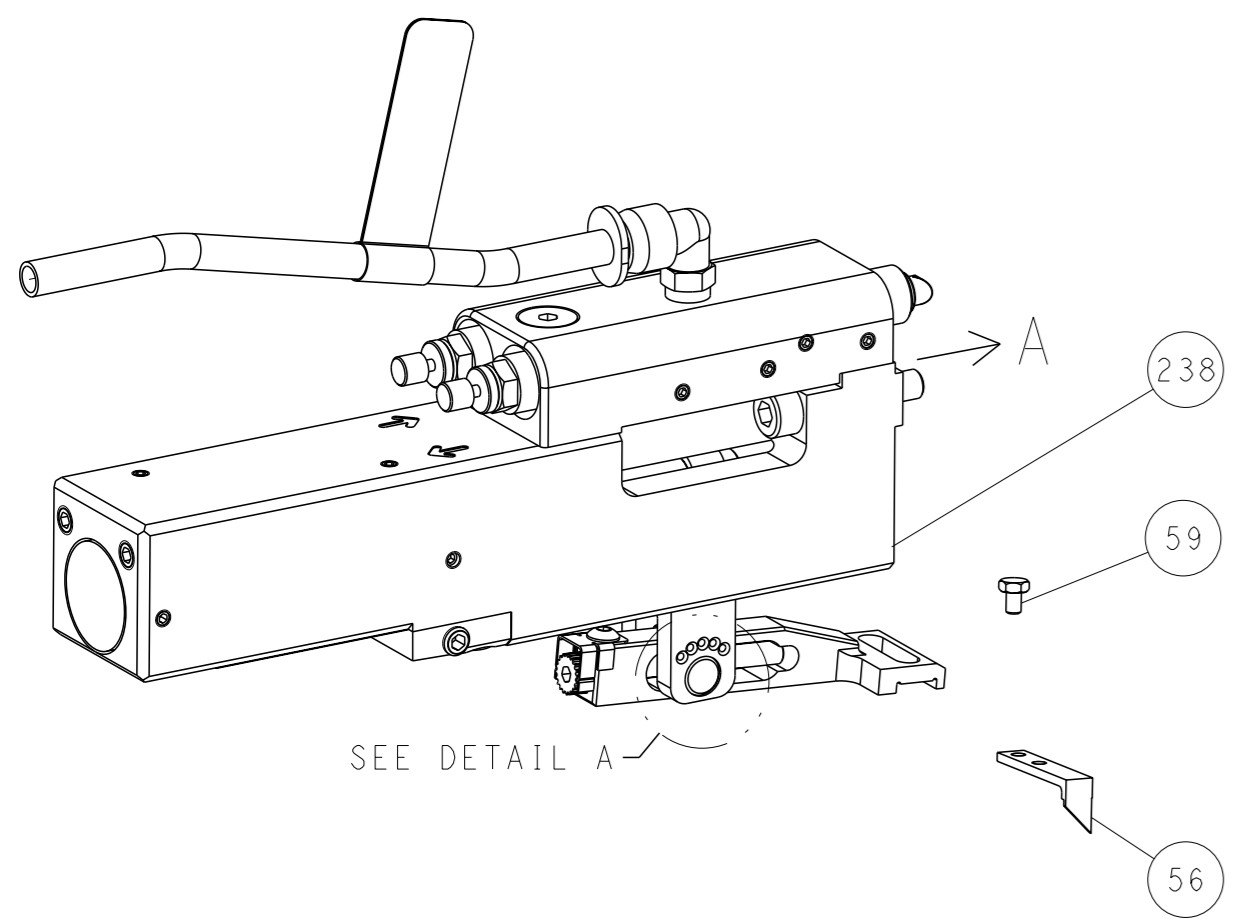

FEED SPRING SETTING POSITION (SHOWN FROM REAR SIDE)

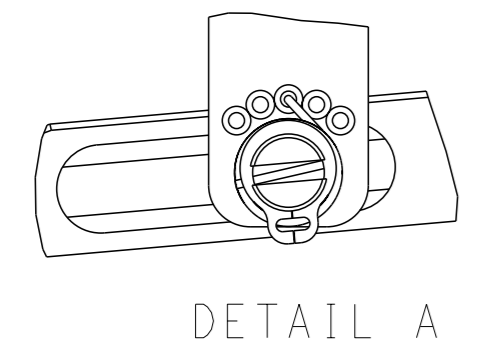

DETAIL A

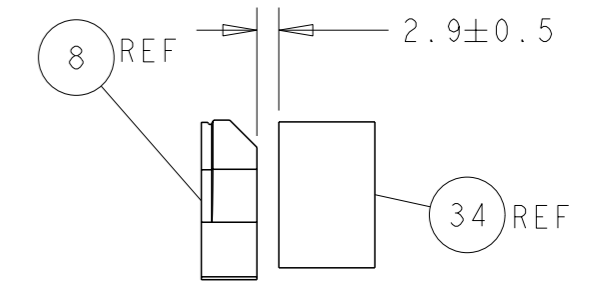
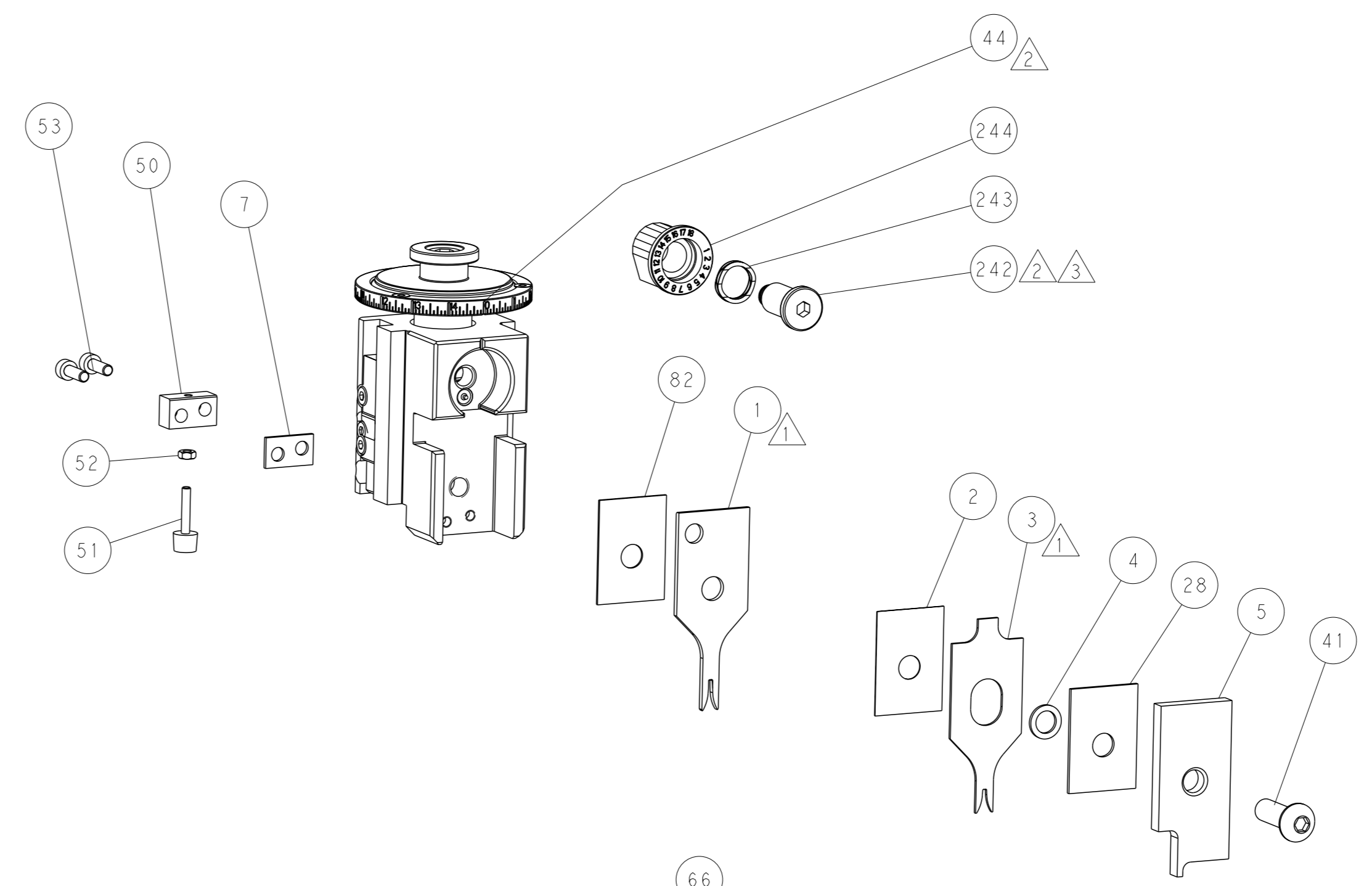

TERMINAL SUPPORT LOCATION

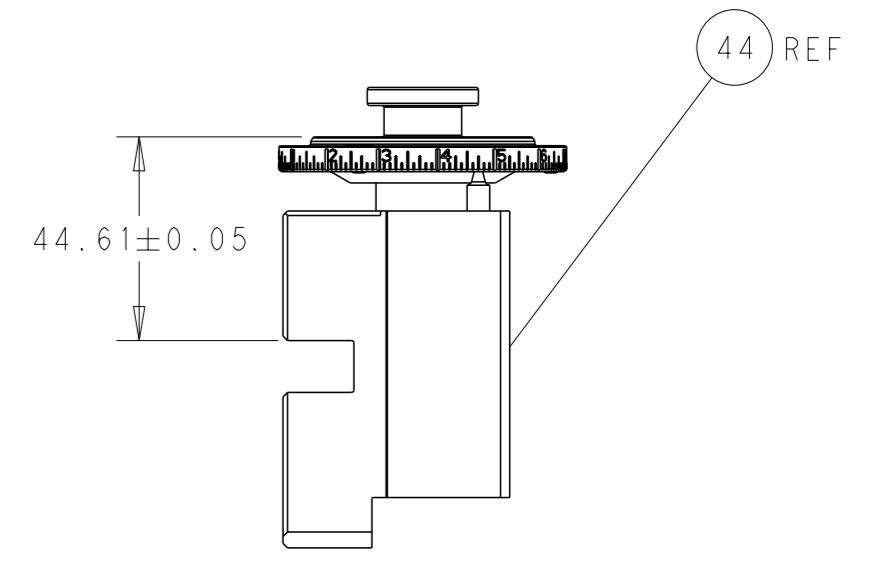

RAM SET-UP

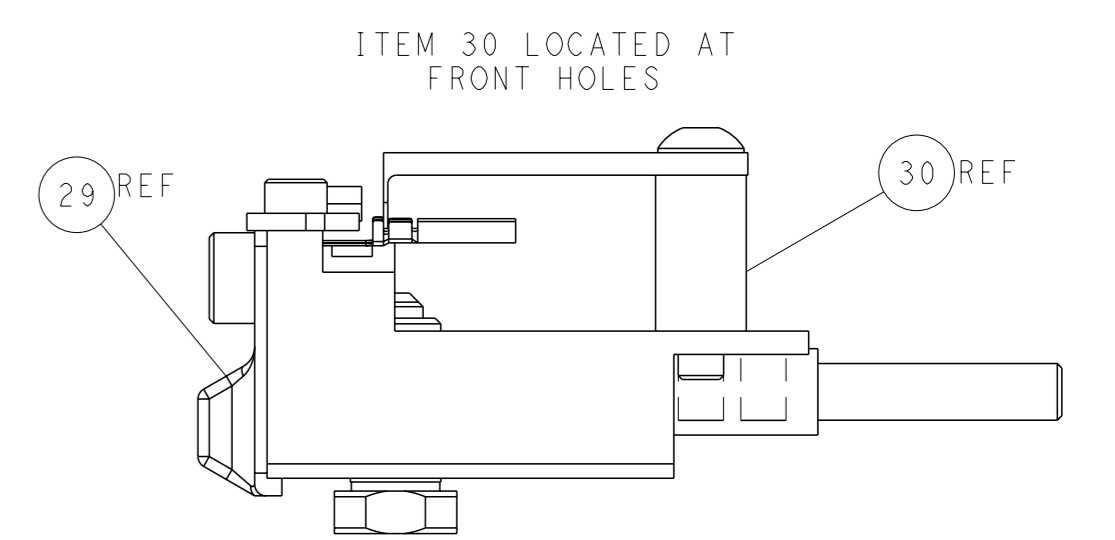
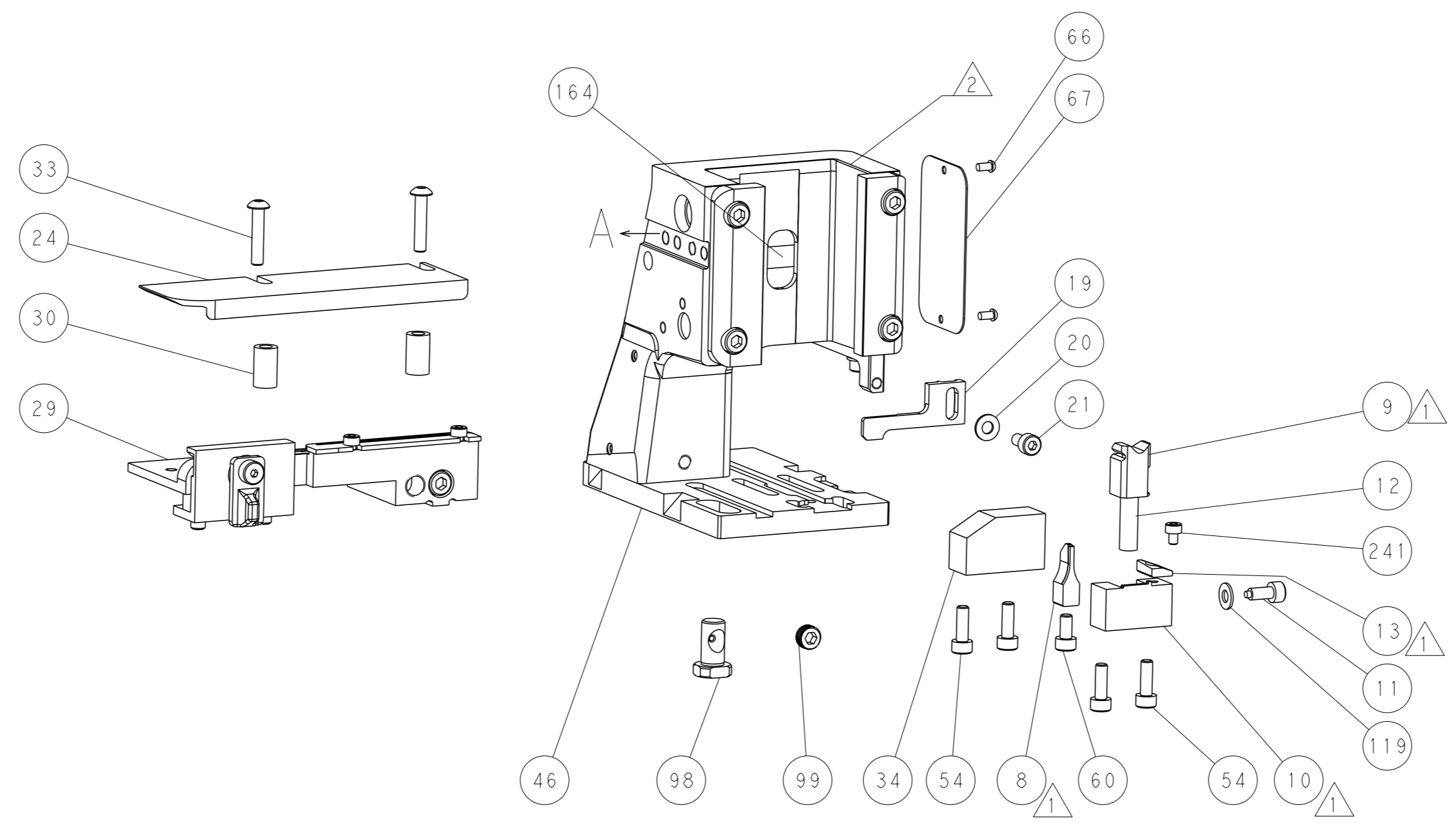

ITEM 30 LOCATED AT FRONT HOLES

CAM POSITIONS

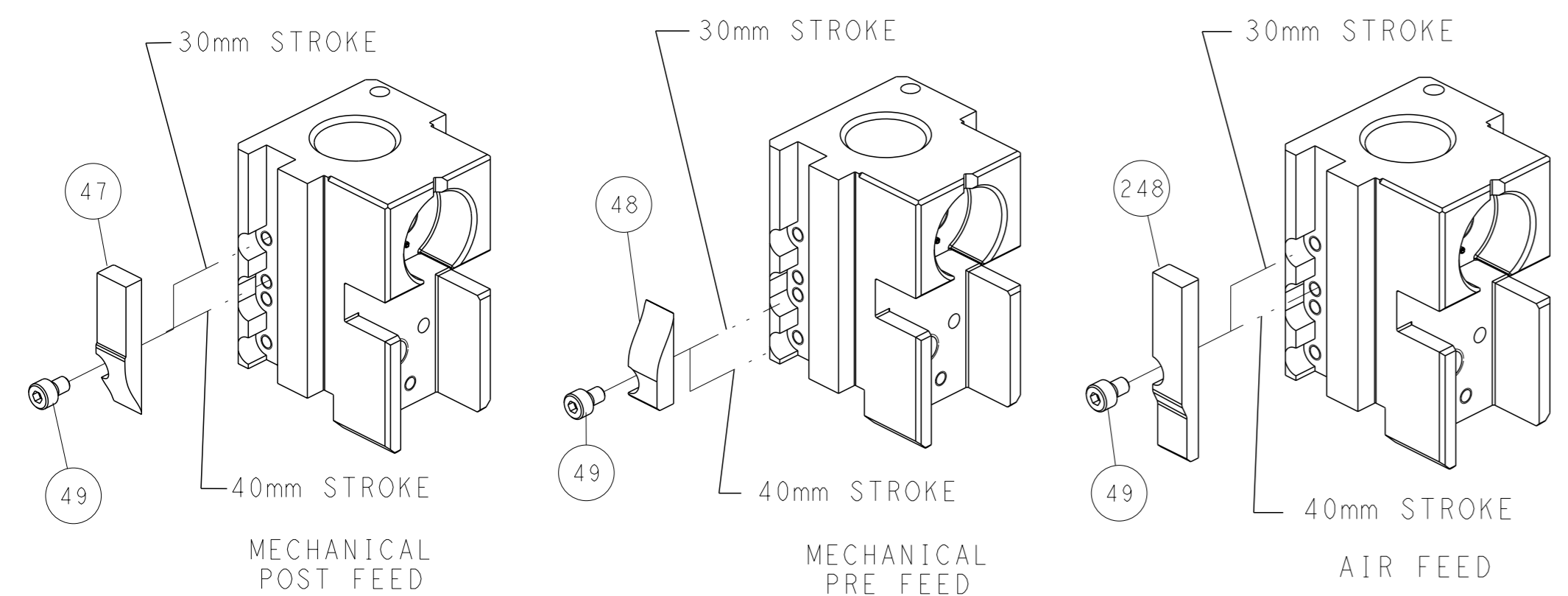

ATLANTIC VERSION
 Shown on sheets 1 of 4 & 2 of 4
 (Pacific version shown on sheets 3 of 4 & 4 of 4)

<small>THIS DRAWING IS A CONTROLLED DOCUMENT FOR TYCO ELECTRONICS CORPORATION. IT IS SUBJECT TO CHANGE AND TO CONTROLING ENGINEERING DISCRETION SHOULD BE CONTACTED FOR THE LATEST REVISION.</small>		OWN: HOFFNER 19APR2013 CHK: T. ELBIN 22APR2013 APVD: T. ELBIN 22APR2013 PRODUCT SPEC APPLICATION SPEC	NAME: TE Connectivity Harrisburg, PA 17105-3608 SIZE: A1 CAGE CODE: 00779 DRAWING NO: 2151929 RESTRICTED TO:
DIMENSIONS: mm TOLERANCES UNLESS OTHERWISE SPECIFIED: 0 PLC ± 1 PLC ± 2 PLC ± 3 PLC ± 4 PLC ± ANGLES ±	MATERIAL:	WEIGHT:	SCALE: 1:2 SHEET: 2 of 4 REV: F

PART NUMBER	REVISION	DESCRIPTION	FEED TYPE
2-2151929-1	F	FINE CRIMP HEIGHT ADJUST	MECHANICAL
2-2151929-2	F	FINE CRIMP HEIGHT ADJUST	PNEUMATIC
7-2151929-7	A	CRIMP TOOLING KIT	-

PACIFIC VERSION TERMINATOR
 INTERFACE ADAPTER

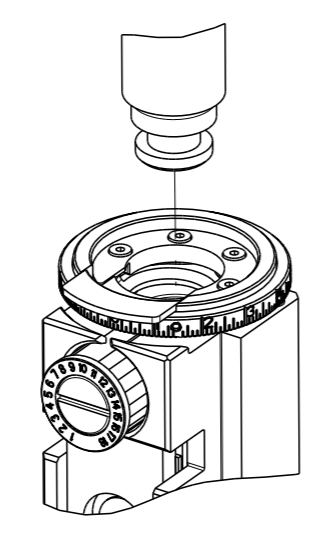

APPLICATOR DATA		
CRIMP	SIZE	TYPE
WIRE	1.40 mm [.055]	F
INSUL	1.60 mm [.063]	F
APPLICATOR INSTRUCTIONS 408-35042		

TERMINAL DATA: MOLEX TERMINAL MOLEX CRIMP SPECIFICATION	
TERMINAL NAME: MICRO-FIT (3.0) FEMALE CRIMP TERMINAL	
WIRE STRIP LENGTH 2.54-2.92 mm [1.00-.115 IN]	INSULATION DIAMETER RANGE Ø1.10-1.30 mm [1.043-.051 IN]
TERMINAL APPLICATION SPECIFICATION 63901-8800 Rev C	-

TERMINAL DATA: ANDERSON TERMINAL MOLEX CRIMP SPECIFICATION	
TERMINAL NAME: MICRO-FIT (3.0) FEMALE CRIMP TERMINAL	
WIRE STRIP LENGTH 2.54-2.92 mm [1.00-.115 IN]	INSULATION DIAMETER RANGE Ø1.10-1.30 mm [1.043-.051 IN]
TERMINAL APPLICATION SPECIFICATION 63901-8800 Rev C	-

TERMINALS APPLIED			
TE TERMINAL	MOLEX TERMINAL	TE TERMINAL	MOLEX TERMINAL
286747-1	43030-0003	286974-2	43031-0002
286747-2	43030-0002	286974-3	43031-0003
286747-3	43030-0001	286974-4	43031-0017
286747-4	43030-1001	286974-5	43031-0018
286747-5	43030-0051	286974-6	43031-0051
286747-6	43030-0052	286974-7	43031-0052
286747-7	43030-0053	286974-8	43031-0053
286747-8	45773-0001	286974-9	43031-0102
286747-9	45773-0002	1-286974-0	43031-0103
1-286747-0	45773-0003	1572840-1	44372-0002
1-286747-1	45773-0053	1572840-2	44372-3606
286974-1	43031-0001		

TERMINALS APPLIED			
TE TERMINAL	ANDERSON TERMINAL	TE TERMINAL	ANDERSON TERMINAL
1-286747-2	4202G1	1-286974-1	4203G1
1-286747-3	4202G3	1-286974-2	4203G3

WIRE SIZE	CRIMP HEIGHT mm [INCH]	CRIMP HEIGHT REFERENCE SETTING
20 AWG OR 0.50mm ²	0.95+/-0.04 [1.0375+/- .0015]	8.3
22 AWG OR 0.35mm ²	0.875+/-0.035 [1.0345+/- .0015]	9.1
24 AWG OR 0.20mm ²	0.815+/-0.035 [1.032+/- .0011]	9.8

- 1 RECOMMENDED SPARE PARTS
- 2 REFER TO SUPPLIED INSTRUCTION SHEET FOR CLEANING, LUBRICATION AND STORAGE OF APPLICATOR.
- 3 APPLY PART NUMBER 2-23419-6 LOCTITE TO THREADS OF ITEM 242.
- 4 CRIMP HEIGHT REFERENCE SETTING WAS THE SETTING USED WHEN THE APPLICATOR WAS QUALIFIED AT THE FACTORY. ADJUSTMENT MAY BE NECESSARY WHEN RUNNING APPLICATOR IN THE FIELD.
- 5 THIS APPLICATOR IS FOR INSULATION RANGE 1.10-1.30. REFER TO APPLICATOR 2151941 FOR INSULATION RANGE 2.31-2.77. REFER TO APPLICATOR 2151375 FOR INSULATION RANGE 1.30-1.85.
- 6. UNLESS SPECIFIED OTHERWISE TORQUE VALUES SHALL BE USED PER DOCUMENT, 101-35000.

***WARNING**
 ON INSTALLATION, SET WIRE DISC TO CRIMP HEIGHT REFERENCE SETTING FOR LARGEST WIRE SIZE. CRIMP HEIGHT REFERENCE SETTINGS GREATER THAN THE VALUE SHOWN MAY CAUSE DAMAGE TO THE CRIMP TOOLING, REFER TO THE INSTRUCTION SHEET FOR PROPER SETUP AND ADJUSTMENTS.

LOC	DIST	REVISIONS					
		P	LY#	DESCRIPTION	DATE	OWN	APVD
A	66	-	-	SEE SHEET 1	-	-	-

-	1	1	2119082-9	CAM, SNAIL, INSULATION ADJUSTMENT	244	
-	1	1	2079764-1	WASHER, WAVE SPRING, CREST-TO-CREST	243	
3	-	1	1	2119083-1	RETAINER, INSULATION DIAL	242
-	1	1	7-18023-7	SCR, SKT HD CAP M3 X 4.0	241	
-	-	1	1	2119580-1	MECHANICAL FEED ASSEMBLY	239
-	1	-	1	2844940-1	AIR FEED MODULE	238
-	REF	REF	1	994970-2	COUNTER, MAGNETIC	164
-	1	-	1	2119641-2	FEED CAM, AIR FEED	151
-	1	1	1	2168083-8	SCR, SKT HD CAP, RoHS, M4 X 16	144
-	4	4	1	2168083-9	SCR, SKT HD CAP, RoHS, M4 X 20	143
-	-	1	1	2119653-2	FEED CAM, POST FEED	142
-	1	1	1	1-1803583-0	APPLICATOR BASIC ASSEMBLY, SF	141
-	1	1	1	1803516-1	RAM ASSEMBLY, SF PACIFIC	140
-	1	1	1	1-18028-2	WASHER, FLAT, REG M4	119
-	1	1	1	2844908-1	SCREW, LOCKING	99
-	1	1	1	2844907-1	POST, LOCKING	98
-	1	1	1	455888-6	SPACER, CRIMPER	82
-	1	1	1	1803607-3	DOCUMENTATION PACKAGE	71
-	1	1	1	2119740-1	TAG, IDENTIFICATION	67
-	2	2	1	2168078-1	SCREW, DRIVE, RH, RoHS, 2 x .188	66
-	1	1	1	5-18022-5	SCR, HEX HD CAP, M4 X 6.0	59
-	1	1	1	1338685-1	PAWL, FEED	56
-	2	2	1	2168083-3	SCR, SKT HD CAP, RoHS, M4 X 12.0	53
-	1	1	1	5018030-1	NUT, HEX, REG, RoHS, M3	52
-	1	1	1	811242-5	BUMPER, HOLD DOWN	51
-	1	1	1	690753-2	SPACER, TONKER	50
-	1	2	1	18023-9	SCR, SKT HD CAP M4 X 6.0	49
-	-	1	1	2119652-1	FEED CAM, PRE FEED	48
-	1	1	1	1803602-1	SCR, BHSC, RoHS (M8 X 25)	41
-	1	1	1	1752356-3	SUPPORT, TERMINAL	34
-	2	2	1	2079383-5	SCR, BHSC, RoHS (M4 X 20)	33
-	2	2	1	2-2844962-4	SPACER, CYLINDRICAL, STRIP GUIDE	30
-	1	1	1	2844992-1	ASSEMBLY, STRIP GUIDE	29
-	1	1	1	1-455888-0	SPACER, CRIMPER	28
-	1	1	1	1320928-2	STRIP GUIDE	24
-	1	1	1	2168083-2	SCR, SKT HD CAP, RoHS, M4 X 8.0	21
-	1	1	1	1-18028-2	WASHER, FLAT, REG M4	20
-	1	1	1	2119533-1	STRIPPER, SIDE FEED	19
1	-	1	1	2119806-1	INSERT, SHEAR	13
-	1	1	1	3-22280-3	SPRING, COMPRESSION	12
-	1	1	1	1-356885-4	STOP, SHEAR	11
-	1	1	1	2119805-1	SHEAR HOLDER, FRONT	10
1	-	1	1	1803095-1	FLOATING SHEAR, FRONT	9
1	1	1	1	1-1633917-6	ANVIL, COMBINATION	8
-	1	1	1	3-240641-9	SPACER	7
-	-	-	-	-	-	6
-	1	1	1	2119757-8	DEPRESSOR, SHEAR	5
-	1	1	1	5-238011-3	BLOCK, CRIMPER SPACER	4
1	1	1	1	7-2119582-6	CRIMPER, INSULATION F PREMIUM	3
-	1	1	1	455888-3	SPACER, CRIMPER	2
1	1	1	1	1-456402-5	CRIMPER, WIRE PREMIUM	1

PACIFIC VERSION
 Shown on sheets 3 of 4 & 4 of 4
 (Atlantic version shown on sheets 1 of 4 & 2 of 4)

DIMENSIONS: mm 		TOLERANCES UNLESS OTHERWISE SPECIFIED: 0 PLC ± 1 PLC ± 2 PLC ± 3 PLC ± 4 PLC ± ANGLES FINISH ±		OWN: HOFFNER 19APR2013 CHK: T. ELBIN 22APR2013 APVD: T. ELBIN 22APR2013 PRODUCT SPEC APPLICATION SPEC		NAME: STE TE Connectivity Harrisburg, PA 17105-3608 Ocean Side Feed Applicator	
MATERIAL: -		WEIGHT: -		SIZE: A1 00779 C=2151929		RESTRICTED TO: -	
Customer Accessible Production Drawing				SCALE: 1:2		SHEET 3 OF 4 REV F	

LOC		DIST		REVISIONS			
A	66	P	LYR	DESCRIPTION	DATE	OWN	APVD
		-		SEE SHEET 1	-	-	-

FEED TYPE MECHANICAL

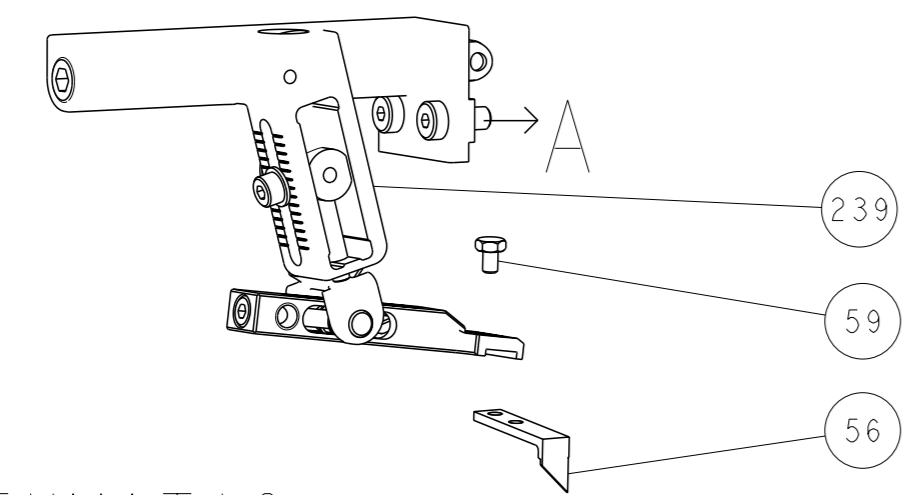

PNEUMATIC

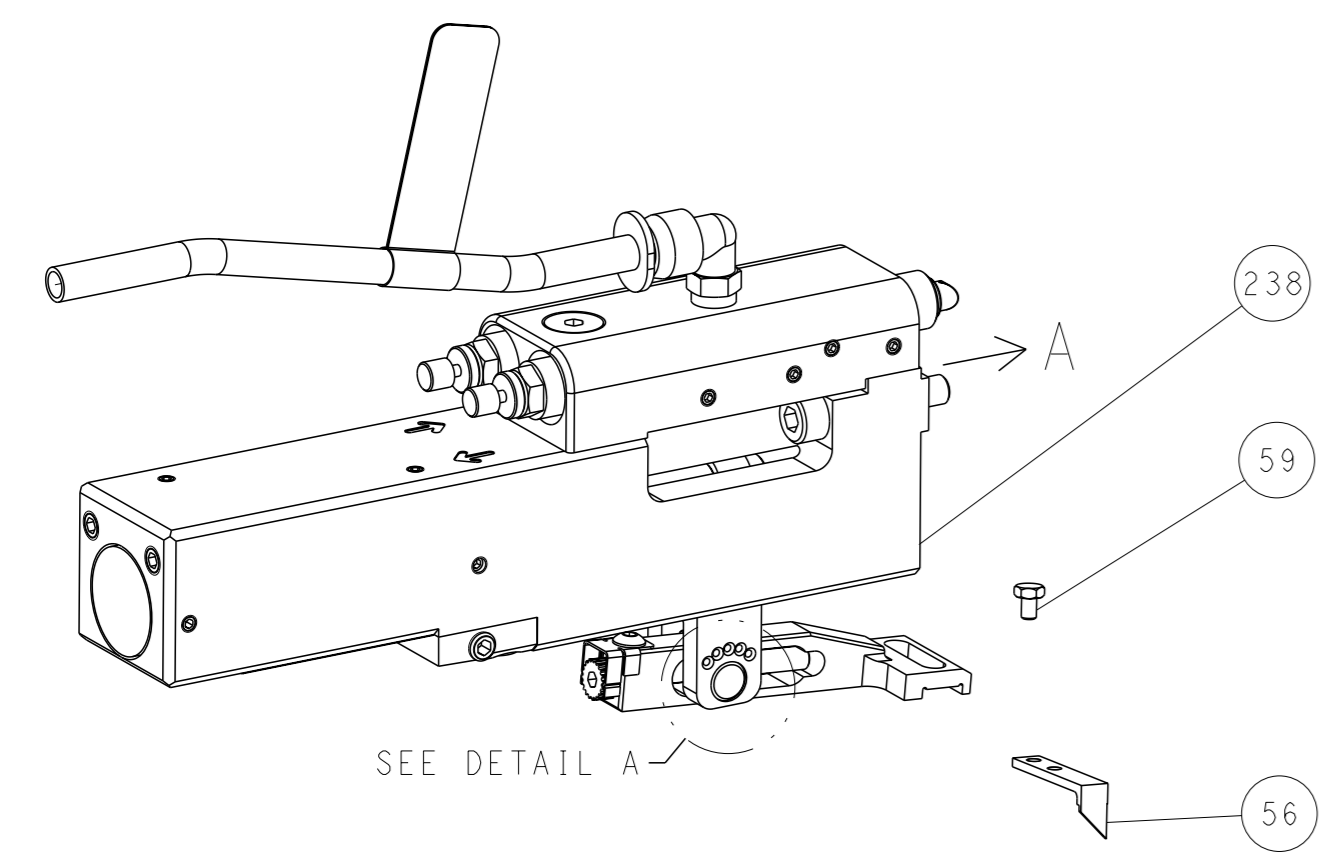

FEED SPRING SETTING POSITION (SHOWN FROM REAR SIDE)

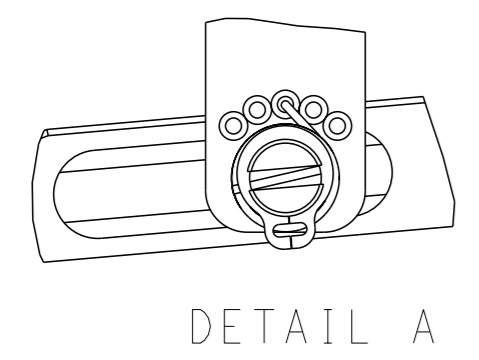

DETAIL A

CAM POSITIONS

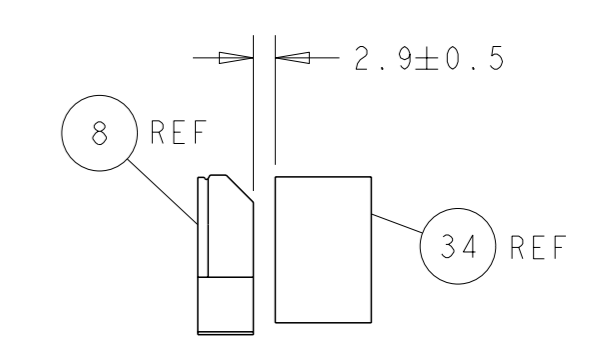
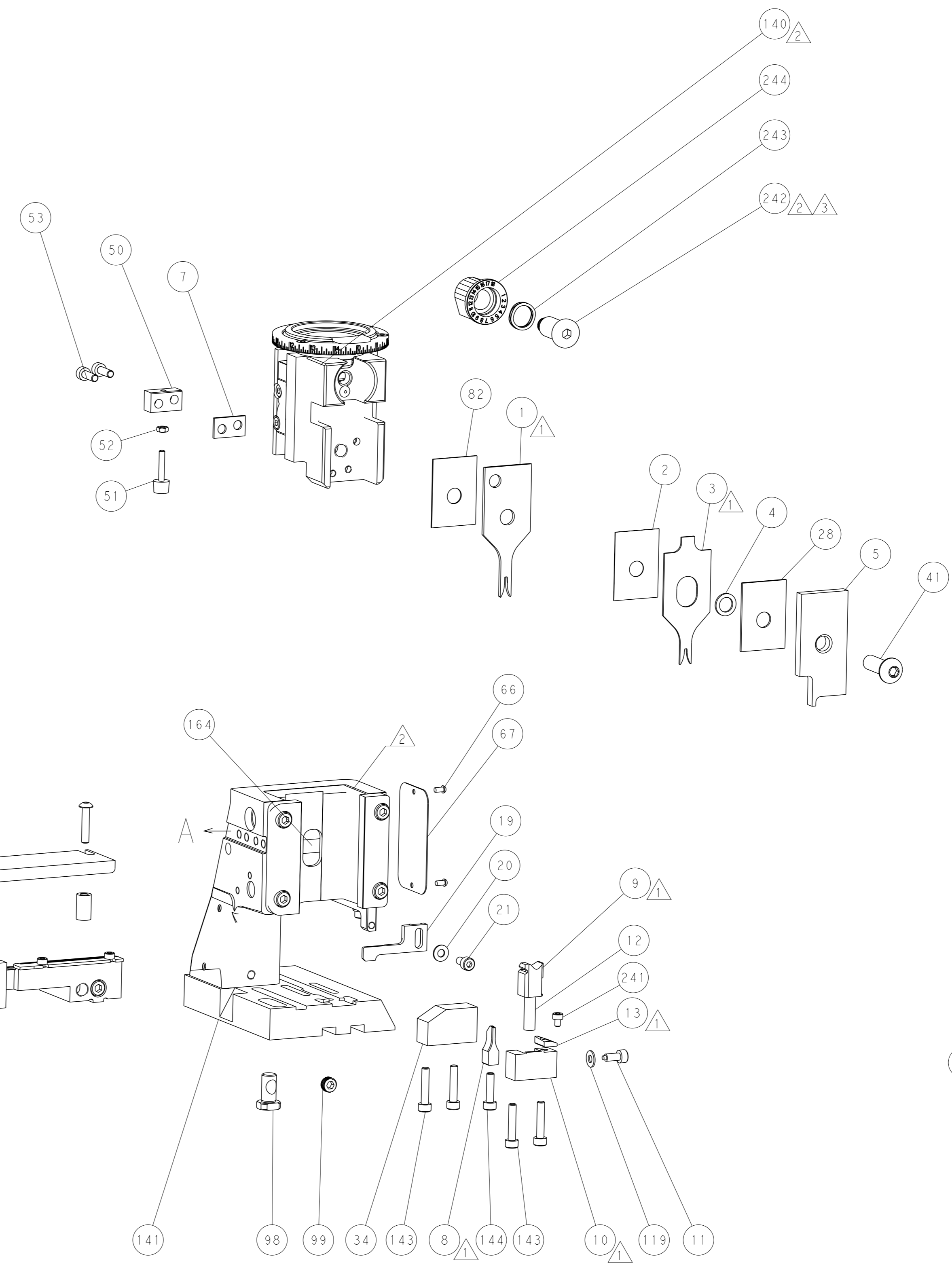
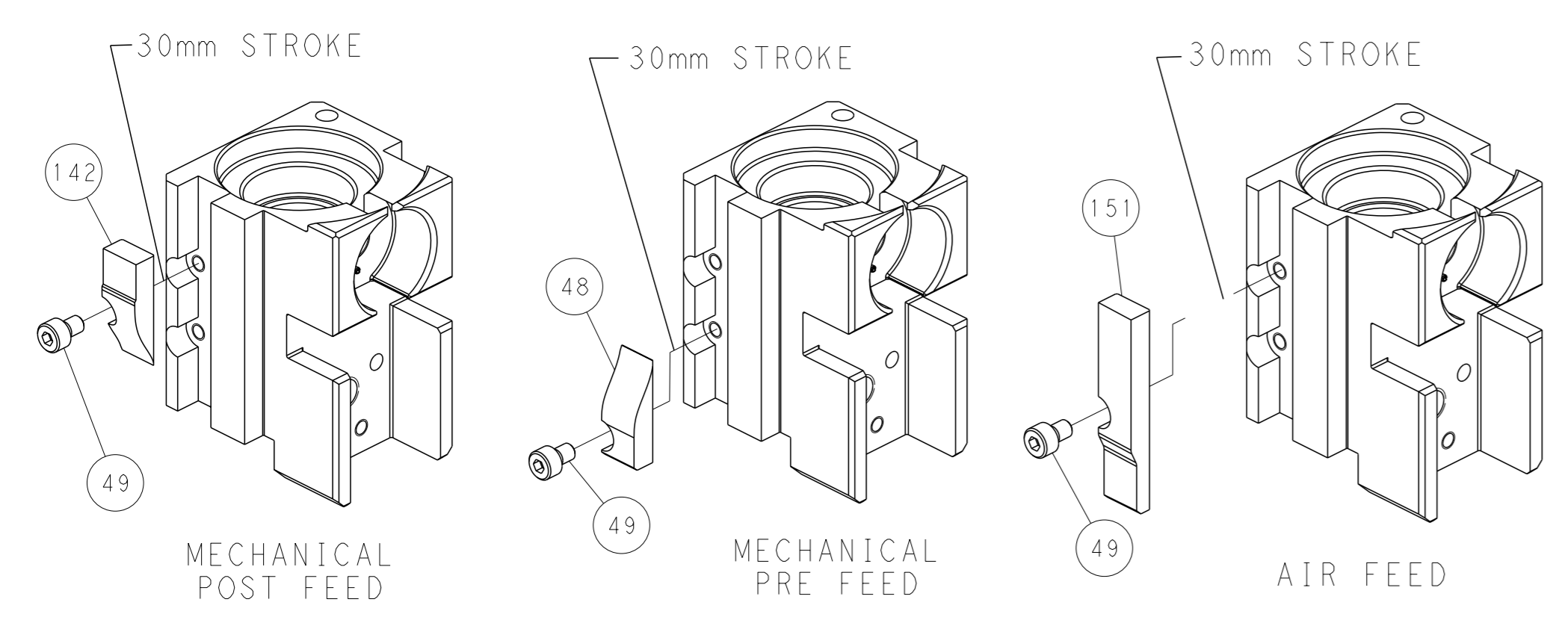

TERMINAL SUPPORT LOCATION

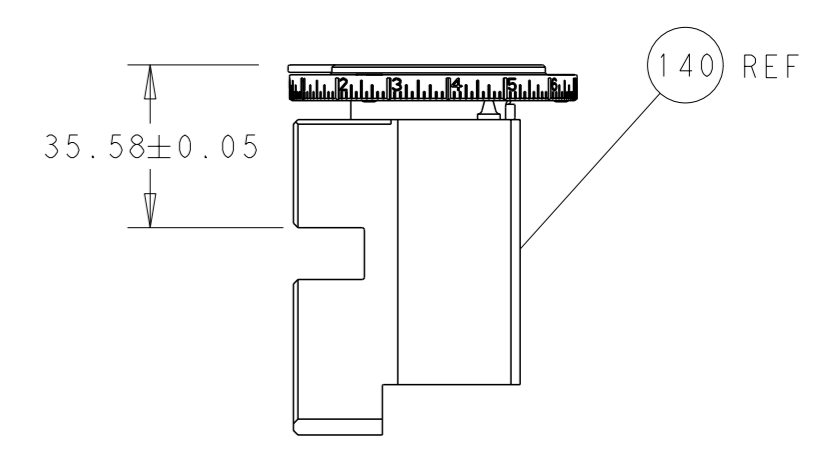

RAM SET-UP

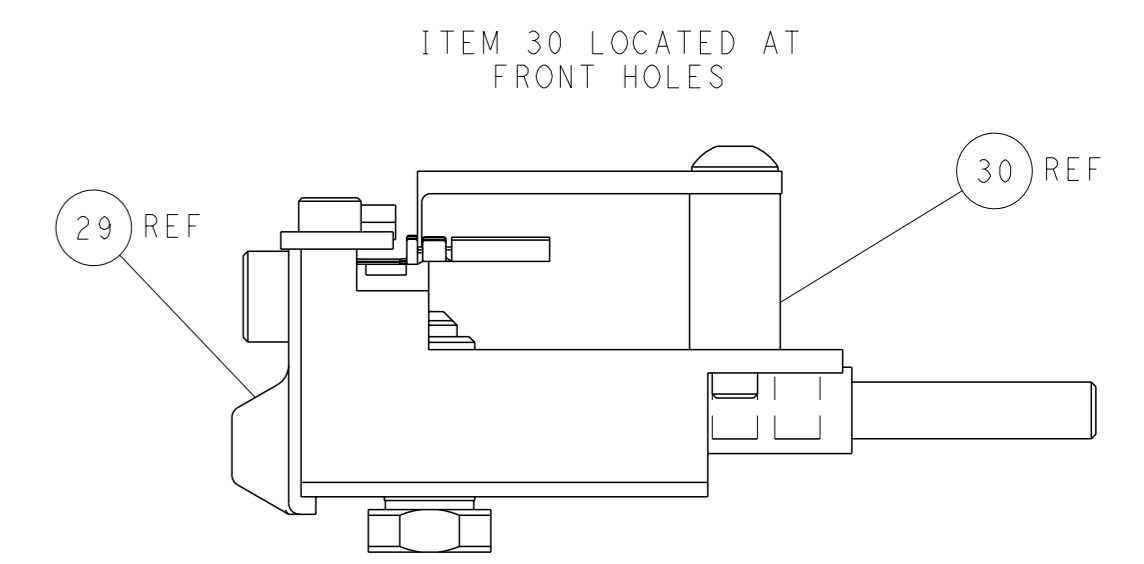

FEED TRACK POSITION
GUIDE BY INSULATION BARREL

PACIFIC VERSION
 Shown on sheets 3 of 4 & 4 of 4
 (Atlantic version shown on sheets 1 of 4 & 2 of 4)

<small>THIS DRAWING IS A CONTROLLED DOCUMENT FOR TYCO ELECTRONICS CORPORATION. IT IS SUBJECT TO CHANGE AND THE CONTROLLING ENGINEERING ORGANIZATION SHOULD BE CONTACTED FOR THE LATEST REVISION.</small>		DWN: HOFFNER 19APR2013 CHK: TELBIN 22APR2013 APVD: TELBIN 22APR2013	TE Connectivity Harrisburg, PA 17105-3608
DIMENSIONS: mm TOLERANCES UNLESS OTHERWISE SPECIFIED: 0 PLC ± 1 PLC ± 2 PLC ± 3 PLC ± 4 PLC ± ANGLES FINISH ±	NAME: Ocean Side Feed Applicator APPLICATION SPEC: - SIZE: A1 CAGE CODE: 00779 DRAWING NO: 2151929	RESTRICTED TO: - SCALE: 1:2 SHEET: 4 of 4 REV: F	CUSTOMER ACCESSIBLE PRODUCTION DRAWING