

NOTE:
 1. QUANTITY: 280PCS/REEL.
 2. 4REELS IN A CARTON.
 3. COMPLIANT TO RoHS DIRECTIVE 2011/65/EUAND ELV DIRECTIVE 2000/53/EC.

| P/N | DESCRIPTION | QUANTITY |
|-----------|--------------|----------|
| 887992500 | CARRIER TAPE | 4 |
| 887962105 | CARTON | 1 |
| 887962333 | DESSICANT | 1 |

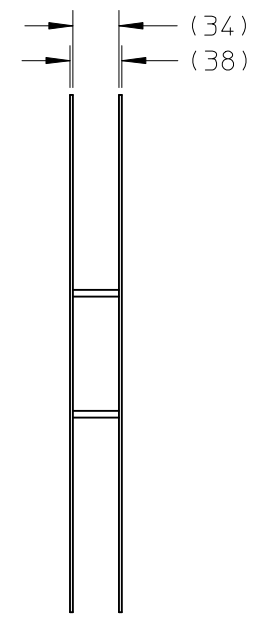
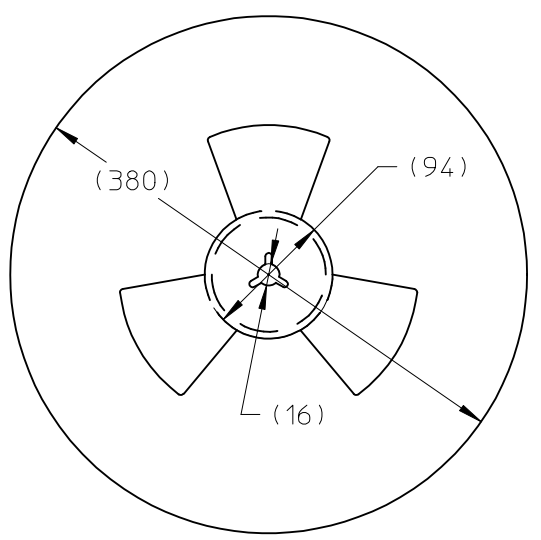

| | | | | | | | | | | |
|---|--------------------|--|---------------------------------------|---|----------------------------|--------------|------------|------------------------|--|--------------|
| SEE MARKED AREA EC NO: SH2016-0023 DRWN:FCHEN11 2015/08/06 CHKD: APPR:AYIN 2015/09/08 | DESCRIPTION REV | QUALITY SYMBOLS | GENERAL TOLERANCES (UNLESS SPECIFIED) | | DIMENSION STYLE MM ONLY | | SCALE | DESIGN UNITS METRIC | THIRD ANGLE PROJECTION | |
| | | $F_A=0$ | 4 PLACES | mm | INCH | DRAWN BY | DATE | TITLE | PK DRAWING FOR 67329 FOR USB 2.0, SMT TH | |
| | | $F_C=0$ | 3 PLACES | ± --- | ± --- | FCHEN11 | 2015/06/19 | | | |
| | | $F_P=0$ | 2 PLACES | ± 0.15 | ± --- | CHECKED BY | DATE | APPROVED BY | | DATE |
| | | | 1 PLACE | ± 0.25 | ± --- | AYIN | 2015/09/08 | MATERIAL NO. | | DOCUMENT NO. |
| | | ANGULAR ± 3 ° | | SEE CHART | | PK-67329-804 | | 1 OF 1 | | |
| | | DRAFT WHERE APPLICABLE MUST REMAIN WITHIN DIMENSIONS | | THIS DRAWING CONTAINS INFORMATION THAT IS PROPRIETARY TO MOLEX INCORPORATED AND SHOULD NOT BE USED WITHOUT WRITTEN PERMISSION | | | | | | |