

Do not populate U1A, U1B, U2A, U2B. These are reserved for MM device on-chip internal operational amplifiers

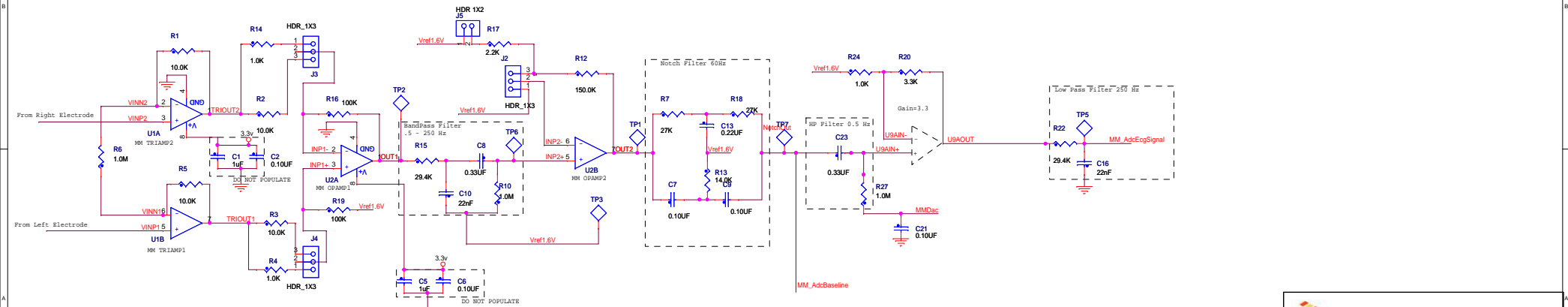

freescale
semiconductor

ICAP Classification: FCP FIUC: X PUB: _____
Drawing Title: **MED-EKG**

Page Title: **EKG Instrumentation & DSC**

Size C	Document Number SCH-26527 PDF: SPF-26527	Rev B3
Date: Tuesday, August 03, 2010		Sheet 3 of 3