

AGV-TMR25XC (CAN)

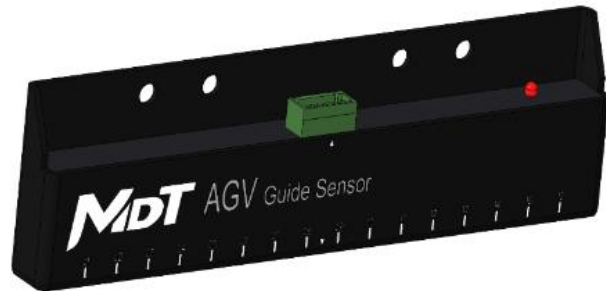

AGV Magnetic Guide Sensors

DESCRIPTION

AGV-TMR25XC is a 16-channel digital output magnetic guide sensor providing CANopen and customizable CAN protocol with RS-232 and CAN interface. It is available as standard with N pole, S pole and N/S pole magnetic modes including corresponding LED indicators. With 16-channel digital signal and 1 mm accuracy absolute position output, AGV-TMR25XC sensor is adaptive to installation height and tape width with excellent protection against magnetic material interference. Incorporating tunneling magnetoresistance (TMR) technique, AGV-TMR25XC sensors are designed to provide excellent temperature characteristics, good consistency, fast frequency response, high sensitivity and low power consumption performance.

FEATURES AND BENEFITS

- CANopen and customizable CAN communication protocol
- Magnetic pole indicator
- 16-channel digital output
- 1 mm accuracy absolute position output
- Support 3 magnetic tracks detection
- Magnetic tape/marker detection
- N pole, S pole and N/S poles detection modes
- Reverse polarity protection, overload protection, surge suppression
- Adaptive installation height
- Superior protection against EMI
- Superior protection against magnetic material interference
- Excellent temperature characteristics

APPLICATIONS

- Magnetic navigation with tape/marker
- Automated guided vehicle (AGV)
- Automated guided cart (AGC)
- Trackless mobile shelving
- Logistics sortation

AGV-TMR25XC (CAN)

AGV Magnetic Guide Sensors

SPECIFICATIONS

Parameters	Value
Supply voltage	10 Vdc ~ 30 Vdc
Supply current	50 mA
Communication type	RS232, CANopen, CAN customizable
Circuit protection	reverse polarity protection, overload protection, surge suppression
Output signal 1	pole status and track quantity
Output signal 2	16-channel digital
Output signal 3	absolute position
Operating mode of N pole	green LED stay lit constantly
Operating mode of S pole	red LED stay lit constantly
Operating mode of N/S pole	red / green LED alternating blink
Detectable tracks	up to 3
Accuracy	1 mm
Effective detection range	0~150 mm
Detection height	10 mm~60 mm
Optimum Installation Height	35 mm
Magnetic field	5 Gs~25 Gs
Operating temperature	-25°C~80°C
Operating humidity	35%~95%
Response time	5 ms
Dimensions	180 mm*17 mm*50 mm
Potting material	AB glue
Housing material	Metal, Epoxy Resin
Ingress Protection	IP65

RS-232, CAN COMMUNICATION PROTOCOL

RS-232 protocol is customizable to communicate with host computer

CAN is based on customizable and CANopen protocol, details as follows:

Interface	CAN BUS 2.0A
Node ID	1~127 (default 4)
Baud rate	125 kbps, 250 kbps, 500 kbps, 800 kbps, 1000 kbps (default)
Transfer rate	50Hz, 80Hz, 100Hz (default), 125Hz, 200Hz (active reporting mode only)
Frame type	standard
Frame format	Data frame
Communication protocol	CAN customizable(default), CANopen

AGV-TMR25XC (CAN)

AGV Magnetic Guide Sensors

1. Customizable CAN Protocol

Customizable CAN protocol include two modes: active reporting and passive tracking. The active reporting mode allows automatically broadcasting navigation data messages from sensor at a set rate. Instead, the host sends the data request message, and the slave responds and returns the navigation data messages in the passive tracking mode.

1) Active reporting mode

Active mode message

CAN-ID	Data field (DLC=6)					
0X580+04	UInt8_t	UInt8_t	UInt8_t	UInt8_t	UInt8_t	UInt8_t
	00	FF	FF	FF	00	00
0X580 + slave ID	pole status and track quantity	1 st track position	2 nd track position	3 rd track position	position high byte	position low byte

Frame sequence of active mode

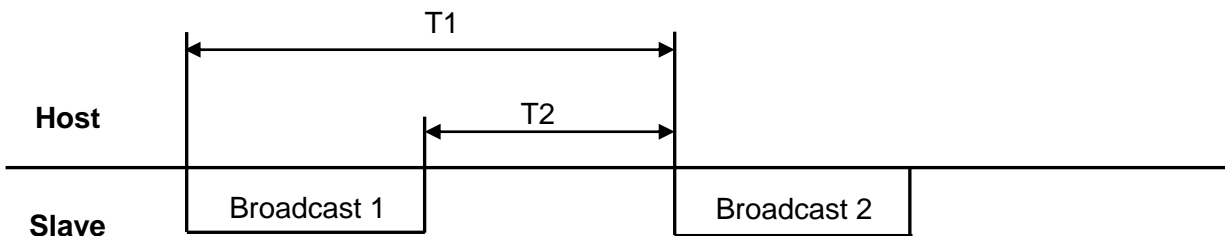

Frame sequence and data transfer rate correlation

Data transfer rate	50 Hz	80 Hz	100 Hz	125 Hz	200 Hz
T1	20 ms	12.5 ms	10 ms	8 ms	5 ms
T2	<20 ms	<12 ms	<10 ms	<8 ms	<5 ms

Note: T1 and T2 are baud rate dependent, T2<T1.

2) Passive tracking mode

Host sends data request

CAN-ID	Data field (DLC=2)	
0X600+04	UInt8_t	UInt8_t
	4D	04
0X600 + slave ID	data request byte	data request byte

AGV-TMR25XC (CAN)

AGV Magnetic Guide Sensors

Slave returns navigation data

CAN-ID	Data field (DLC=8)							
0X580+04	UInt8_t	UInt8_t	UInt8_t	UInt8_t	UInt8_t	UInt8_t	UInt8_t	UInt8_t
	4D	04	00	FF	FF	FF	00	00
0X580+ slave ID	data request return byte	data request return byte	pole status and track quantity	1 st track position	2 nd track position	3 rd track position	position high byte	position low byte

Frame sequence of passive mode



Frame configuration

Baud rate	125 kbps	250 kbps	500 kbps	800 kbps	1000 kbps
T1	< 1 ms	< 1 ms	< 1 ms	< 1 ms	< 1 ms
T2	> 3 ms	> 4 ms	> 4 ms	> 4 ms	> 4 ms
T3	≥ 5 ms	≥ 5 ms	≥ 5 ms	≥ 5 ms	≥ 5 ms

Note:

- ① T1 is the minimum response time, T2 > T1
- ② T3 is the minimum data request time interval

2. CANopen Protocol

The CANopen is a CAN based multi-host fieldbus communication protocol. AGV_TMR25XC fully supports CANopen Protocol DS301 V4.02, and passes the CiA (CAN in Automation) consistency testing.

1) Electronic Data Sheet (EDS)

The EDS file is the manual which describes the function of CANopen node device. In most cases, the EDS file of node device are mandatory to import to corresponding node into host devices. Please contact sales to get proper EDS files.

2) Object Dictionary

Object dictionary (OD) is the core of CANopen device, which describes all objects of the CANopen device.

AGV-TMR25XC (CAN)

AGV Magnetic Guide Sensors



Index	Sub Index	Description	Default	Type	R/W
0x1000		Device Type	0	UINT32	R
0x1001		Error Register	0	UINT8	R
0x1005		SYNC COB ID	0	UINT32	RW
0x1008		Manufacture Device Name	AGV-TMR25XC	STRING	R
0x1009		Manufacture Hardware Version		R	
0x100A		Manufacture Software Version		R	
0x100C		Guard Time	10000	UINT16	RW
0x100D		Life Time Factor	3	UINT8	RW
0x1010		Store Parameters			
	0	Number of Entries	4	UINT8	R
	1	Save All Parameters	0	UINT32	RW
	2	Save Communication Parameters	0	UINT32	RW
	3	Save Application Parameters	0	UINT32	RW
	4	Save Manufacture Parameters	0	UINT32	RW
0x1011		Restore Default Parameters			
	0	Number of Entries	3	UINT8	R
	1	Restore All Default Parameters	0	UINT32	RW
	2	Restore Manufacture Default Parameters	0	UINT32	RW
	3	Restore Application Parameters	0	UINT32	RW
	4	Restore Manufacture Defined Default Parameters	0	UINT32	RW
0x1014		Emergency COB ID	0x84	UINT32	RW
0x1017		Producer Heartbeat Time	0	UINT16	RW
0x1018		Identity			
	0	Number of Entries	4	UINT8	R
	1	Vendor ID	77	UINT32	R
	2	Product Code	0	UINT32	R
	3	Revision Number	0	UINT32	R
	4	Serial Number	0	UINT32	R
0x1200		Server SDO Parameter			
	0	Number of Entries	2	UINT8	R
	1	COB ID Client to Server	&NODEID+0x600	UINT32	R
	2	COB ID Server to Client	&NODEID+0x580	UINT32	R
0x1800		Transmit PDO 1 Parameter			
	0	Highest Sub Index Supported	6	UINT8	R
	1	COB ID used by PDO	0x184	UINT32	RW
	2	Transmission Type	254	UINT8	RW
	3	Inhibit Time	50	UINT16	RW

AGV-TMR25XC (CAN)

AGV Magnetic Guide Sensors

	4	Compatibility Entry	0	UINT8	RW
	5	Event Timer	10	UINT16	RW
	6	SYNC start value	0	UINT8	RW
0x1A00		Transmit PDO 1 Mapping			
	0	Number of Entries	5	UINT8	R
	1	PDO1 Mapping for Variable 1	0x20000108	UINT32	RW
	2	PDO1 Mapping for Variable 2	0x20000208	UINT32	RW
	3	PDO1 Mapping for Variable 3	0x20000308	UINT32	RW
	4	PDO1 Mapping for Variable 4	0x20000408	UINT32	RW
	5	PDO1 Mapping for Variable 5	0x20000510	UINT32	RW
0x2000		Sensor Output			
	0	Number of Entries	5	UINT8	R
	1	Field Number	0	UINT8	R
	2	Field1 Value	0xff	UINT8	R
	3	Field2 Value	0xff	UINT8	R
	4	Field3 Value	0xff	UINT8	R
	5	Active Bits Map	0	UINT16	R
0x3000		Device Parameters			
	0	Number of Entries	13	UINT8	R
	1	Data Interface Index	0	UINT8	RW
	2	Sensing Polarity Index	0	UINT8	RW
	3		1	UINT8	RW
	4		4	UINT8	RW
	5		0	UINT8	RW
	6	RS-232 Baudrate Index	4	UINT8	RW
	7	CAN Node ID	4	UINT8	RW
	8	CAN Baudrate Index	4	UINT8	RW
	9	CAN Data Protocol Index	0	UINT8	RW
	10		0	UINT8	RW
	11	RS-232 Loop Mode Index	0	UINT8	RW
	12	RS-232 Modbus ID	1	UINT8	RW
	13	RS-232 Parity Index	0	UINT8	RW

3) Node initialization

The device utilizes transmit process data object protocol TPDO1 (highlighted area in OD table) to transmit sensor data by default. It is quick to use without changes. The process is as follows:

- a) Power-on node device.
- b) Node device is ready and waiting for command by reporting Boot Up frame to network management (NMT) master.

AGV-TMR25XC (CAN)

AGV Magnetic Guide Sensors

c) NMT master send NMT command (e.g. START, STOP) to start or stop data transferring.

User can also build a network by modifying the parameters and mapping of TPDO1.

CAN COMMUNICATION DATA INSTRUCTION

The detection channels of AGV-TMR25XC sensor defined as the figure below:

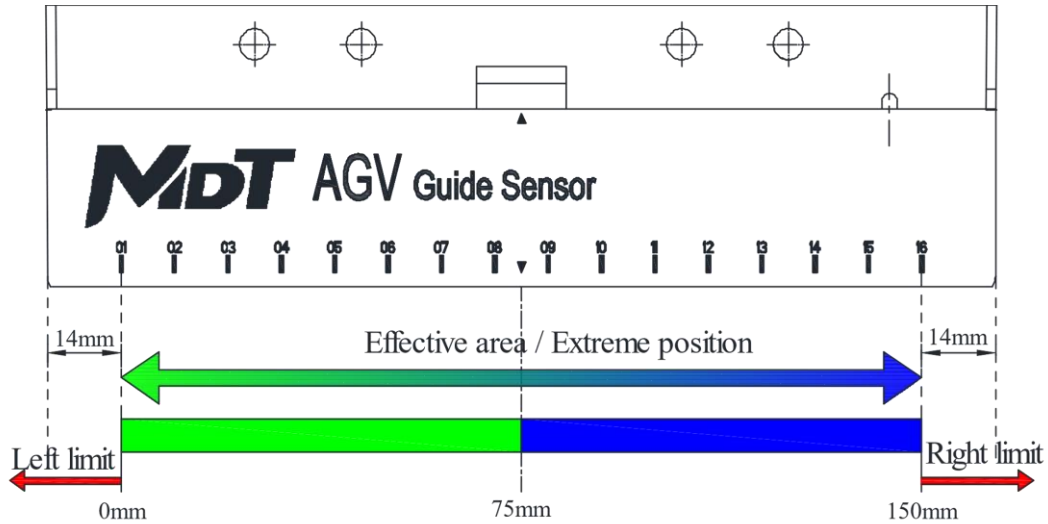

Return data instructions

pole status and track quantity									
Bit #	00		01	02	03	04	05	06	07
Function	pole status		reserved				track quantity		
Status	0: S pole 1: N pole (valid when track quantity>0)		0				00: quantity of tape track is 0 01: quantity of tape track is 1 10: quantity of tape track is 2 11: quantity of tape track is 3		

Point position	High byte								Low byte							
Bit #	00	01	02	03	04	05	06	07	00	01	02	03	04	05	06	07
Channel #	09	10	11	12	13	14	15	16	01	02	03	04	05	06	07	08
Bit Status	0: OFF								1: ON							

AGV-TMR25XC (CAN)

AGV Magnetic Guide Sensors

PIN CONFIGURATION

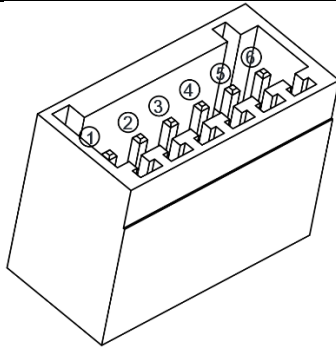

1- 24V	1-
2- GND	2-
3- 232_RX	3-
4- 232_TX	4-
5- CAN_H	5-
6- CAN_L	6-

DIMENSIONS (mm)

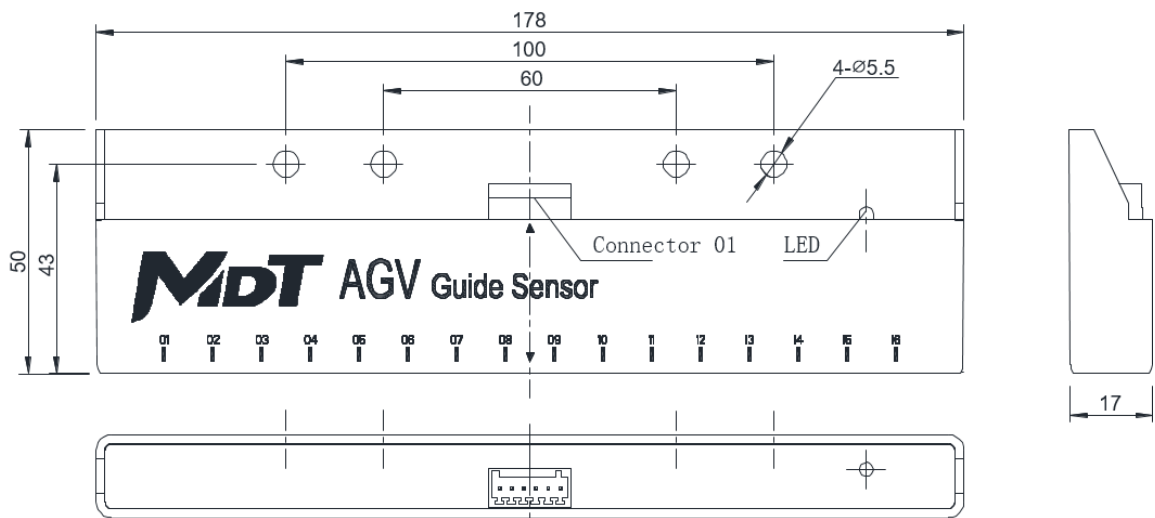

APPENDIX A:

Host software operation manual

Host software requires LabVIEW Run-Time Engine 2013 (not included)

Please download it from NI website or through the link below:

<http://www.ni.com/download/labview-multicore-analysis-and-sparse-matrix-toolkit-2013/4033/en/>

Download and Installation:

1. Download host software package from AGV-TMR25X4 page of MDT official website <http://www.dowaytech.com/sensor/agv.html>, then click the link in yellow circle on the screenshot below to start downloading.

AGV-TMR25XC (CAN)

AGV Magnetic Guide Sensors



2. Start host program

Extract the downloaded file, and click the file of **MDT** in the extracted folder to start host program of AGV-TMR25XC.

Host interface setting and operation:

1. Select AGV-TMR25XC from drop-down menu, then click Start button below to enter the RS-232 and CAN setting interface



2. Menu instruction

2.1 System

- 2.1.1 Demo: Enter product function demonstration interface

2.2 Communication

- 2.2.1 Serial Conn: Connect serial port for RS-232
- 2.2.2 Serial Discon: Disconnect serial port for RS-232

2.3 Parameter

- 2.3.1 Read: Read parameters from sensor to computer
- 2.3.2 Write: Write parameters from computer to sensor

AGV-TMR25XC (CAN)

AGV Magnetic Guide Sensors

3. Main interface instruction

3.1 Serial port connection: Set connection parameter for RS-232

This table will update automatically by program. Default setting:

Port	Baud rate	Check	Slave address
(auto search)	115200	NO	01

3.2 RS232: Set RS-232 parameters: slave address, baud rate, check,

Operating mode: Choose sensor working in N/S pole, N pole, or S pole mode.

Click "Write" (see 2.3.2) after input, power off and restart sensor to activate setting.

3.3 CAN: Set CAN parameters: address, baud rate, transfer rate, and protocol

Click "Write" after input, power off and restart sensor to activate setting.

3.4 Sensor Parameter: Load current sensor parameter by clicking "Read"

3.5 Status bar: Current connection status of sensor

4. Demo instruction

Enter demonstration interface by clicking "Demo" (see 2.1.1)

4.1 Static status (no magnetic tape detected):

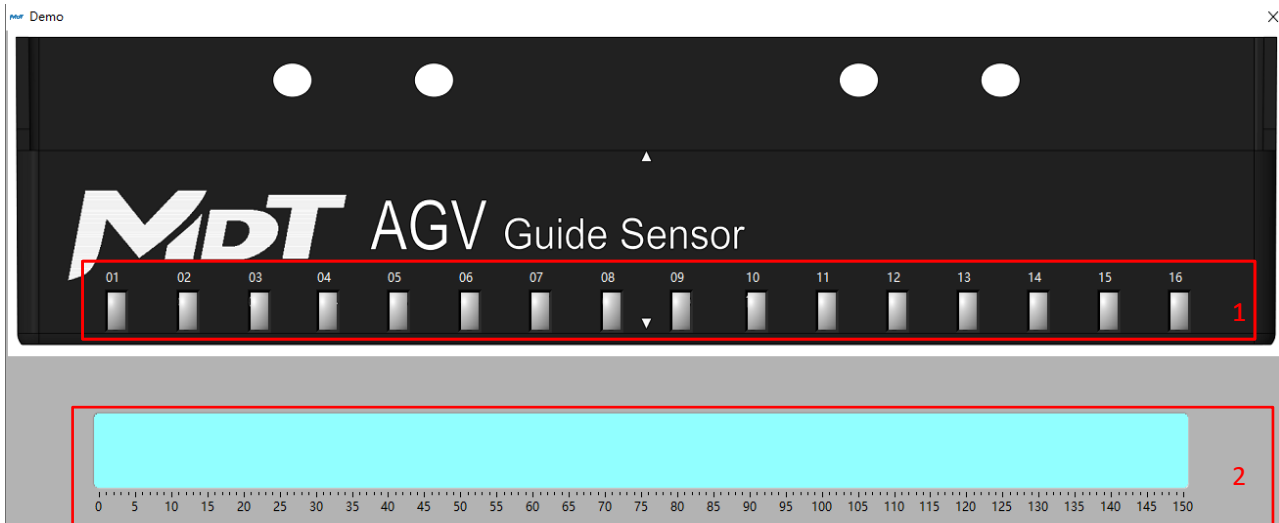

Note

Status of (1) 16 detection channel and (2) 1~150 mm absolute position

4.2 Dynamic status (3 tapes detected)

AGV-TMR25XC (CAN)

AGV Magnetic Guide Sensors

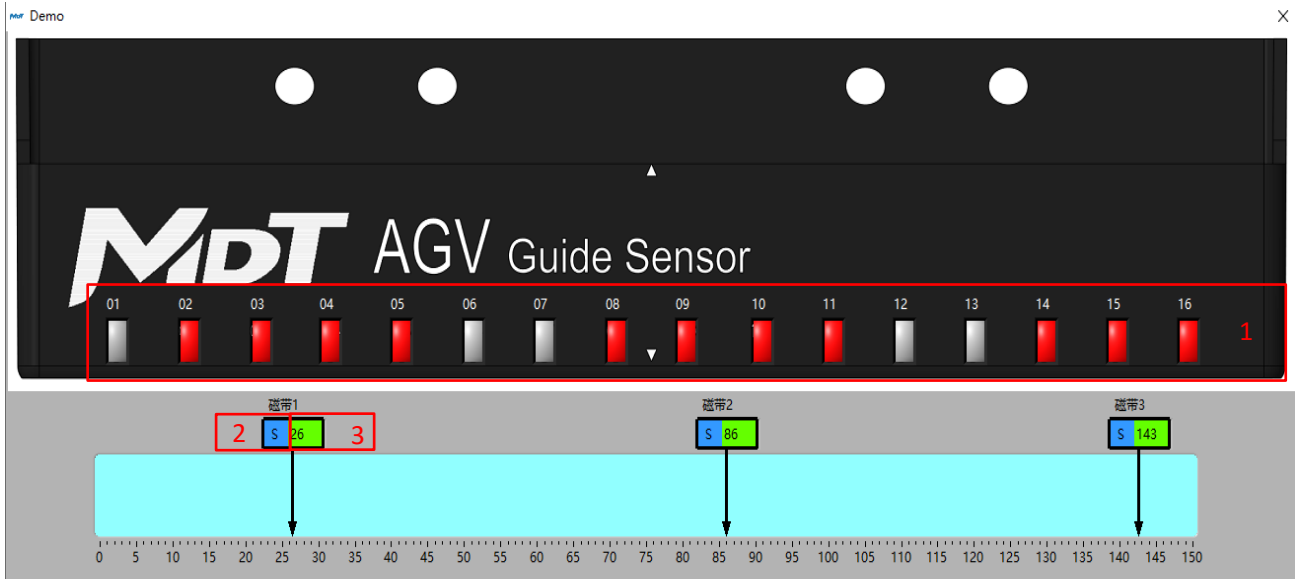

Note

1. 16 channels status
2. current pole of the magnetic tape
3. absolute position of 3 tape tracks

AGV-TMR25XC (CAN)

AGV Magnetic Guide Sensors

```
u16 mc_check_crc16(u8 *buf, u16 len) //CRC16 calculation
{
    u8 index;
    u16 check16=0;
    u8 crc_low=0XFF;
    u8 crc_high=0XFF;
    while(len-->0)
    {
        index=crc_high^(*buf++);
        crc_high=crc_low^CRC16HiTable[index];
        crc_low=CRC16LoTable[index];
    }
    check16 +=crc_high;
    check16 <<=8;
    check16+=crc_low;
    return check16;
}
```

The information provided herein by MultiDimension Technology Co., Ltd.(hereinafter MultiDimension) is believed to be accurate and reliable. Publication neither conveys nor implies any license under patent or other industrial or intellectual property rights. MultiDimension reserves the right to make changes to product specifications for the purpose of improving product quality, reliability, and functionality. MultiDimension does not assume any liability arising out of the application and use of its products. MultiDimension's customers using or selling this product for use in appliances, devices, or systems where malfunction can reasonably be expected to result in personal injury do so at their own risk and agree to fully indemnify MultiDimension for any damages resulting from such applications.

MultiDimension Technology Co., Ltd.
No.7 Guangdong Road, Zhangjiagang Free Trade Zone
Jiangsu, 215634, China
www.dowaytech.com/en
info@dowaytech.com