

protective adhesive tape surface

Material Anodized aluminium

For models with connectors SMA, QMA, SMA 2.9, Din 1.6/5.6

Model	Type	Options	Number of positions	RADIALL part number
R573 series R573 series R574 series	All 4,5,8 & 9 All	2 & 8 All All	3 to 6	R599920000
R573 series R574 series	All	All	7 & 8	R599920000
R573 series R574 series	All	All	9 & 10	R599921000
R573 series R574 series	All	All	11 & 12	R599922000

For models with connectors N, TNC, BNC

Model	Type	Options	Number of positions	RADIALL part number
R573 series R574 series	All	All	3 to 6	R599921000

(* For 7 to 12 positions models, brackets are not available)

ADHESIVE BONDING PROCESS

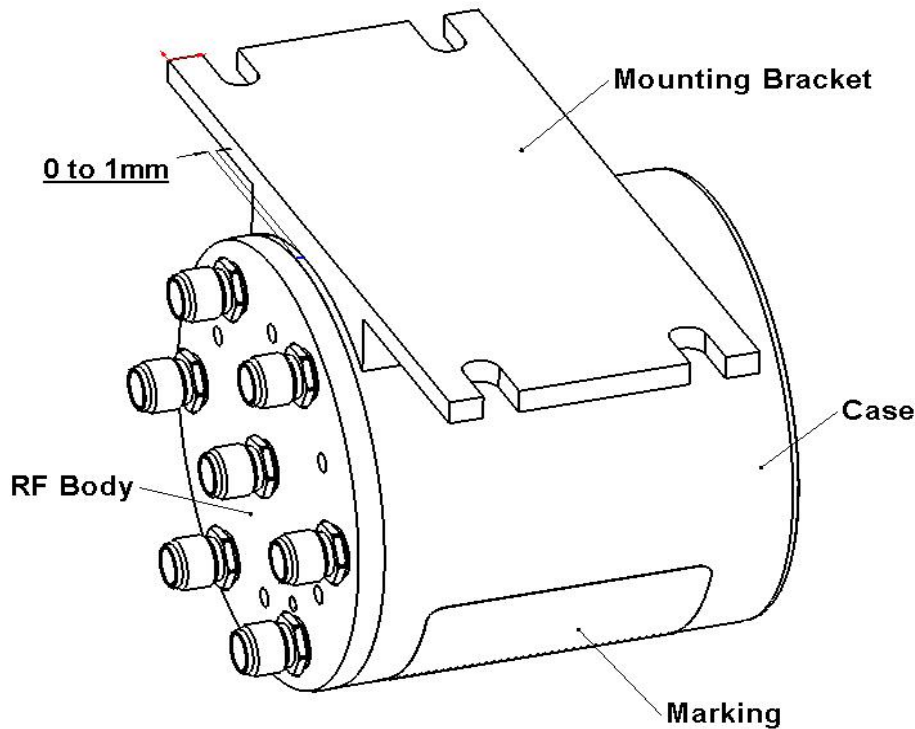

- 1) Clean the can with alcohol (Isopropanol or Ethanol).
- 2) Remove the protective adhesive tape surface.
- 3) Glue the mounting bracket **ONLY** on the blue can and **NOT** on the RF body.
DO NOT glue mounting bracket on the marking (See drawing).
- 4) Firmly press the mounting bracket against the can, and maintain pressure for several seconds (10 seconds min) then, unit is now properly bonded (See note 1 & 2).
- 5) Product can be fixed in your equipment with four screws (non included).

Note 1: Adhesive tape may not be used more than one time.

Note 2: Adhesive bonding does not require polymerization.

CAUTION: Mounting Bracket may reduce the shocks and vibrations levels guaranteed for the standard product