

PART NUMBER	REVISION	DESCRIPTION	FEED TYPE
2151491-1	V	FINE CRIMP HEIGHT ADJUST	MECHANICAL
2151491-2	V	FINE CRIMP HEIGHT ADJUST	PNEUMATIC
3-2151491-2	V	FINE CRIMP HEIGHT ADJUST	DOUBLE ACTING PNEUMATIC WITH SENSORS <sup>9</sup>
5-2151491-1	V	SEAL STRIPPER CRIMPER TERMINATING UNIT	MECHANICAL
5-2151491-2	V	SEAL STRIPPER CRIMPER TERMINATING UNIT	PNEUMATIC
7-2151491-1	V	MECHANICAL AND CRIMP TOOLING KIT	MECHANICAL
7-2151491-2	V	PNEUMATIC AND CRIMP TOOLING KIT	PNEUMATIC
7-2151491-7	P	CRIMP TOOLING KIT	-

ATLANTIC VERSION TERMINATOR INTERFACE ADAPTER

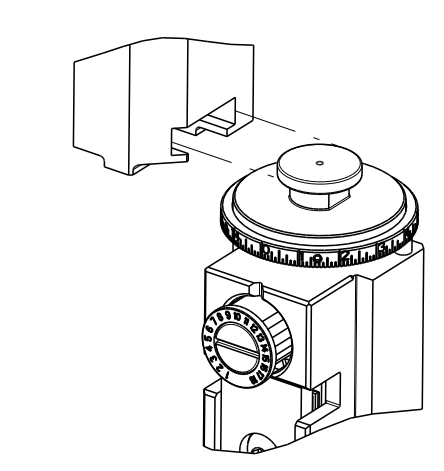

APPLICATOR DATA		
CRIMP	SIZE	TYPE
WIRE	1.40 mm [.055]	F
INSUL	2.03 mm [.080]	O

APPLICATOR INSTRUCTIONS 408-35042

TERMINAL DATA: TE TERMINAL TE CRIMP SPECIFICATION			
TERMINAL NAME: MICRO QUADLOK SYSTEM SOCKET CONTACT			
WIRE STRIP LENGTH		INSULATION DIAMETER RANGE	
3.35-3.65 mm [.132-.144 IN]		Ø1.30-1.90mm [.051-.075 IN]	
TERMINAL APPLICATION SPECIFICATION	(A) 114-18021	-	-
TERMINALS APPLIED <sup>5</sup>			
GROUP 1 <sup>6</sup>		GROUP 2 <sup>7</sup>	
TE TERMINAL	TE TERMINAL	TE TERMINAL	TE TERMINAL
963715-1	963716-1	968221-1	1452013-1
963715-5	963716-2	968221-5	1-1452013-1
963715-6	1-963716-2	968221-6	5-1452013-1
1-963715-5	5-963716-1	5-968221-1	6-1452013-1
5-963715-1	5-963716-2	5-968221-5	
5-963715-5	5-963716-3	5-968221-6	
5-963715-6	6-963716-1	1241920-1	
6-963715-5	6-963716-2	5-1241920-1	

TERMINAL DATA: TE TERMINAL TE CRIMP SPECIFICATION			
TERMINAL NAME: MICRO QUADLOK SYSTEM SOCKET CONTACT			
WIRE STRIP LENGTH		INSULATION DIAMETER RANGE	
3.35-3.65 mm [.132-.144 IN]		Ø1.40-1.90 mm [.055-.075 IN]	
TERMINAL APPLICATION SPECIFICATION	(A) 114-18021	-	-
TERMINALS APPLIED <sup>5</sup>			
GROUP 1 <sup>6</sup>		GROUP 2 <sup>7</sup>	
TE TERMINAL	TE TERMINAL	TE TERMINAL	TE TERMINAL
1801529-1	1703282-2		
1801529-2	5-1703282-1		
1703282-1	5-1703282-2		

TERMINAL DATA: TE TERMINAL TE CRIMP SPECIFICATION			
TERMINAL NAME: MICRO QUADLOK SYSTEM SOCKET CONTACT			
WIRE STRIP LENGTH		INSULATION DIAMETER RANGE	
3.35-3.65 mm [.132-.144 IN]		Ø1.70-1.90mm [.067-.075 IN]	
TERMINAL APPLICATION SPECIFICATION	(A) 114-18021	-	-
	(B) 114-61024	-	-
TERMINALS APPLIED <sup>5</sup>			
GROUP 1 <sup>6</sup>		GROUP 2 <sup>7</sup>	
TE TERMINAL	TE TERMINAL	TE TERMINAL	TE TERMINAL
(A) 1379418-1	(A) 1703298-1		
(A) 1379418-2	(A) 1703298-5		
(A)5-1379418-1	(A) 2141399-6		
(A)5-1379418-2	(B) 2005120-1		

WIRE SIZE	CRIMP HEIGHT mm [INCH]	CRIMP HEIGHT REFERENCE SETTING
0.75mm2	1.07+/-0.05 [.042+/-0.002]	6.3
0.35+0.35 mm2	1.07+/-0.05 [.042+/-0.002]	6.3
0.22+0.35 mm2	0.94+/-0.05 [.037+/-0.002]	7.6
0.50mm2	0.93+/-0.05 [.037+/-0.002]	7.7
0.22+0.22 mm2	0.88+/-0.05 [.035+/-0.002]	8.2

- <sup>1</sup> RECOMMENDED SPARE PARTS
- <sup>2</sup> REFER TO SUPPLIED INSTRUCTION SHEET FOR CLEANING, LUBRICATION & STORAGE OF APPLICATOR.
- <sup>3</sup> APPLY PART NUMBER 2-23419-6 LOCTITE TO THREADS OF ITEM 242.
- <sup>4</sup> CRIMP HEIGHT REFERENCE SETTING WAS THE SETTING USED WHEN THE APPLICATOR WAS QUALIFIED AT THE FACTORY. ADJUSTMENT MAY BE NECESSARY WHEN RUNNING APPLICATOR IN THE FIELD.
- <sup>5</sup> TERMINAL LUBRICANT IS RECOMMENDED.
- <sup>6</sup> POSITION THE HOLD DOWN, ITEM 297, AS SHOWN FOR GROUP 1 TERMINALS.
- <sup>7</sup> POSITION THE HOLD DOWN, ITEM 297, IN ORIENTATION 2 FOR GROUP 2 TERMINALS
- <sup>8</sup> UNLESS SPECIFIED OTHERWISE TORQUE VALUES SHALL BE USED PER DOCUMENT, 101-35000.
- <sup>9</sup> THIS APPLICATOR IS EQUIPPED WITH THE DOUBLE ACTING FEED WITH SENSORS AND IS APPLICATION SPECIFIC AND DOES NOT REQUIRE ITEMS 49 & 248.

<sup>10</sup> THIS CRIMP PARAMETER IS PROVIDED TO MEET A CUSTOM AND UNIQUE CUSTOMER REQUIREMENT. IT HAS BEEN EVALUATED AND IS CONDITIONALLY SPECIFIED BY TE CONNECTIVITY. THIS CUSTOMIZED CRIMP PARAMETER IS NOT LISTED AS AN APPROVED APPLICATION WITHIN A TE CONNECTIVITY APPLICATION SPECIFICATION. **TE CONNECTIVITY EXPRESSLY DISCLAIMS ANY AND ALL WARRANTIES THAT THE PRODUCT WILL PERFORM SIMILARLY TO VALIDATED AND APPROVED APPLICATIONS, AS STATED WITHIN TE CONNECTIVITY APPLICATION SPECIFICATIONS, INCLUDING BUT NOT LIMITED TO IMPLIED WARRANTIES OF MERCHANTABILITY OR FITNESS FOR PARTICULAR PURPOSE.** AS SUCH, IT IS HIGHLY RECOMMENDED THAT THE CUSTOMER PERFORM FURTHER DETAILED EVALUATION TO ASSESS PRODUCT PERFORMANCE IN THE SPECIFIC APPLICATION.

**\*WARNING**  
ON INSTALLATION, SET WIRE DISC TO CRIMP HEIGHT REFERENCE SETTING FOR LARGEST WIRE SIZE. CRIMP HEIGHT REFERENCE SETTINGS GREATER THAN THE VALUE SHOWN MAY CAUSE DAMAGE TO THE CRIMP TOOLING, REFER TO THE INSTRUCTION SHEET FOR PROPER SETUP AND ADJUSTMENTS.

ATLANTIC VERSION  
Shown on sheets 1 of 4 & 2 of 4  
(Pacific version shown on sheets 3 of 4 & 4 of 4)

LOC	DIST	REVISIONS					
A	66	P	LTN	DESCRIPTION	DATE	OWN	APVD
		V		ECR-21-004218	12APR2021	TB	RK
		V1		ECR-21-005672	21MAY2021	FJ	YY
		V2		ECR-21-006619	30JUN2021	JWC	GB
		V3		ECR-21-110737	19AUG2021	JWC	GB

-	1	1	1	1	1	1	1	1803945-2	TONKER	300
-	1	1	1	1	1	1	1	22278-9	SPRING, COMPRESSION	299
-	2	2	2	2	2	2	2	4-18032-3	SCR, SET, FLT PNT, M3 X 6.0	298
-	1	1	1	1	1	1	1	1803944-1	SPACER, TONKER	297
-	-	-	-	-	-	-	-	2-1803583-1	APPLICATOR BASIC ASSEMBLY, SF	292
-	-	-	-	-	-	-	-	2844950-1	AIR FEED MODULE	290
-	1	-	1	-	-	1	-	2119641-1	FEED CAM, AIR FEED	248
-	1	1	1	1	1	1	1	2119082-5	CAM, SNAIL, INSULATION ADJUSTMENT	244
-	1	1	1	1	1	1	1	2079764-1	WASHER, WAVE SPRING, CREST-TO-CREST	243
-	1	1	1	1	1	1	1	2119083-1	RETAINER, INSULATION DIAL	242
-	1	1	1	1	1	1	1	7-18023-7	SCR, SKT HD CAP M3 X 4.0	241
-	-	1	-	1	-	-	1	2119580-1	MECHANICAL FEED ASSEMBLY	239
-	1	-	1	-	-	1	-	2844940-1	AIR FEED MODULE	238
-	REF	REF	REF	REF	REF	REF	REF	994970-2	COUNTER, MAGNETIC	164
-	1	1	1	1	1	1	1	1-18028-2	WASHER, FLAT, REG M4	119
-	1	1	1	1	1	1	1	2119955-1	ASSY, LUBRICATOR, SIDE FEED	113
-	1	1	1	1	1	1	1	2844908-1	SCREW, LOCKING	99
-	1	1	1	1	1	1	1	2844907-1	POST, LOCKING	98
-	1	1	1	1	1	1	1	455888-6	SPACER, CRIMPER	82
-	1	1	1	1	1	1	1	240641-6	SPACER	81
-	1	1	1	1	1	1	1	1803607-3	DOCUMENTATION PACKAGE	71
-	1	1	1	1	1	1	1	2119791-9	DEPRESSOR, WIRE	70
-	1	1	1	1	1	1	1	2119740-1	TAG, IDENTIFICATION	67
-	2	2	2	2	2	2	2	2168078-1	SCREW, DRIVE, RH, RoHS, 2 x .188	66
-	1	1	1	1	1	1	1	2168083-2	SCR, SKT HD CAP, RoHS, M4 X 8.0	60
-	1	1	1	1	1	1	1	5-18022-5	SCR, HEX HD CAP, M4 X 6.0	59
-	1	1	1	1	1	1	1	1338685-1	PAWL, FEED	56
-	4	4	4	4	4	4	4	2168083-3	SCR, SKT HD CAP, RoHS, M4 X 12.0	54
-	2	2	2	2	2	2	2	2168083-8	SCR, SKT HD CAP, RoHS, M4 X 16	53
-	1	2	1	2	-	1	2	18023-9	SCR, SKT HD CAP M4 X 6.0	49
-	-	1	-	1	-	-	1	2119652-1	FEED CAM, PRE FEED	48
-	-	1	-	1	-	-	1	2119653-1	FEED CAM, POST FEED	47
-	1	1	-	-	1	1	1	1803583-9	APPLICATOR BASIC ASSEMBLY, SF	46
-	1	1	1	1	1	1	1	1803515-1	RAM ASSEMBLY, SF ATLANTIC	44
-	1	1	1	1	1	1	1	1803602-1	SCR, BHSC, RoHS (M8 X 25)	41
-	1	1	1	1	1	1	1	1752356-6	SUPPORT, TERMINAL	34
-	2	2	2	2	2	2	2	2079383-5	SCR, BHSC, RoHS (M4 X 20)	33
-	2	2	2	2	2	2	2	2-2844962-4	SPACER, CYLINDRICAL, STRIP GUIDE	30
-	1	1	1	1	1	1	1	2844992-1	ASSEMBLY, STRIP GUIDE	29
-	1	1	1	1	1	1	1	1320928-2	STRIP GUIDE	24
-	1	1	-	-	1	1	1	2168083-2	SCR, SKT HD CAP, RoHS, M4 X 8.0	21
-	2	2	1	1	2	2	2	1-18028-2	WASHER, FLAT, REG M4	20
-	1	1	-	-	1	1	1	2119533-1	STRIPPER, SIDE FEED	19
-	1	1	1	1	1	1	1	2119806-1	INSERT, SHEAR	13
-	1	1	1	1	1	1	1	3-22280-3	SPRING, COMPRESSION	12
-	1	1	1	1	1	1	1	1-356885-4	STOP, SHEAR	11
-	1	1	1	1	1	1	1	2119805-1	SHEAR HOLDER, FRONT	10
-	1	1	1	1	1	1	1	1803095-3	FLOATING SHEAR, FRONT	9
1	2	2	1	1	1	1	1	1-1338690-1	ANVIL, COMBINATION .055	8
-	1	1	1	1	1	1	1	3-240641-7	SPACER	7
-	1	1	1	1	1	1	1	2119757-4	DEPRESSOR, SHEAR	5
-	1	1	1	1	1	1	1	238011-9	BLOCK, CRIMPER SPACER	4
1	2	2	1	1	1	1	1	2-1633966-9	CRIMPER, INSULATION O	3
1	2	2	1	1	1	1	1	1-1633773-6	CRIMPER, WIRE, STEP	1

DIMENSIONS:	TOLERANCES UNLESS OTHERWISE SPECIFIED:	OWN	CHK	DATE	NAME	SIZE	CAGE CODE	DRAWING NO	RESTRICTED TO
mm	0 PLC ± 1 PLC ± 2 PLC ± 3 PLC ± 4 PLC ± ANGLES ±	B. WEAVER	G. HOFNER	31AUG2011	Ocean Side Feed Applicator	A1	00779	2151491	Customer Accessible Production Drawing
MATERIAL:	FINISH:	APVD	T. ELBIN	31AUG2011					
		PRODUCT SPEC							
		APPLICATION SPEC							
		WEIGHT							
		SCALE	1:2						
		SHEET	1						
		OF	4						
		REV	V3						

LOC	DIST	REV	DATE	BY	APPD
A	66				

# FEED TYPE MECHANICAL

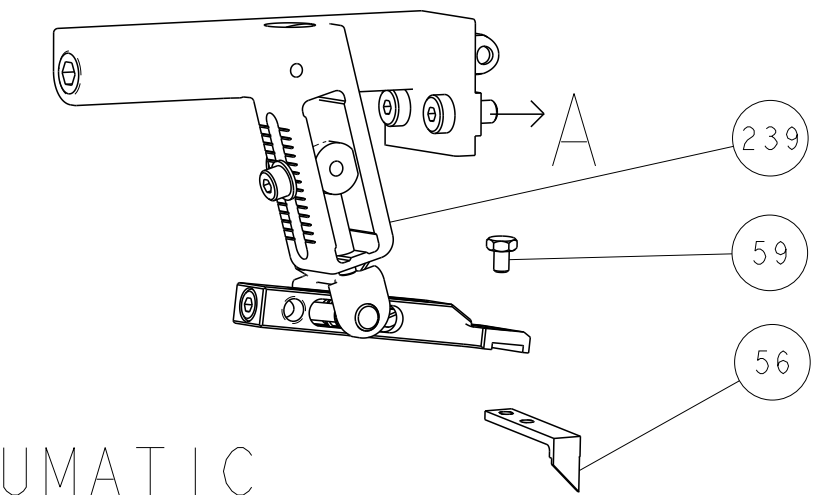

## PNEUMATIC

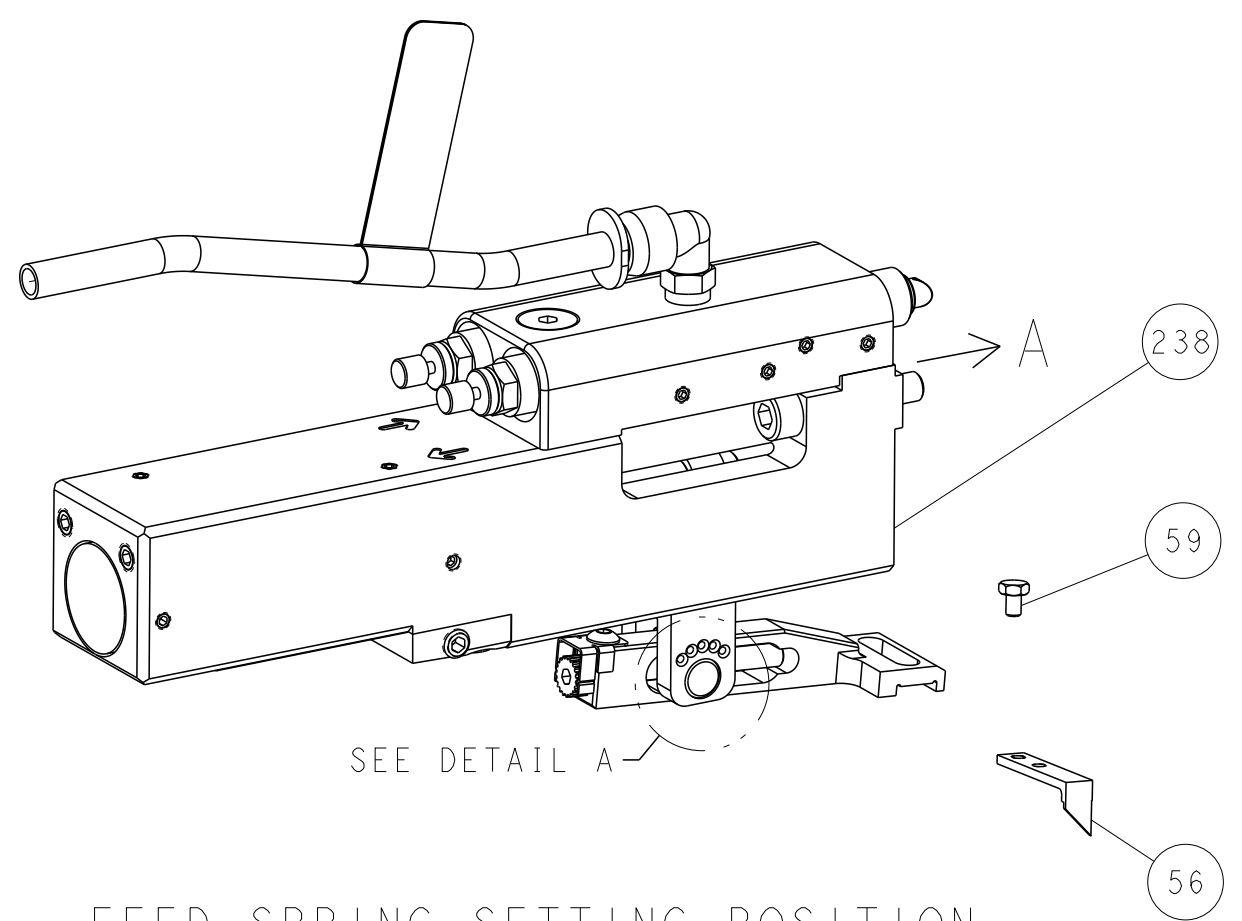

FEED SPRING SETTING POSITION (SHOWN FROM REAR SIDE)

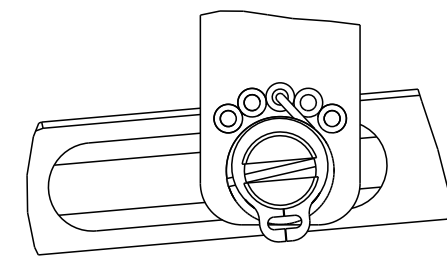

DETAIL A

## DOUBLE ACTING PNEUMATIC WITH SENSORS

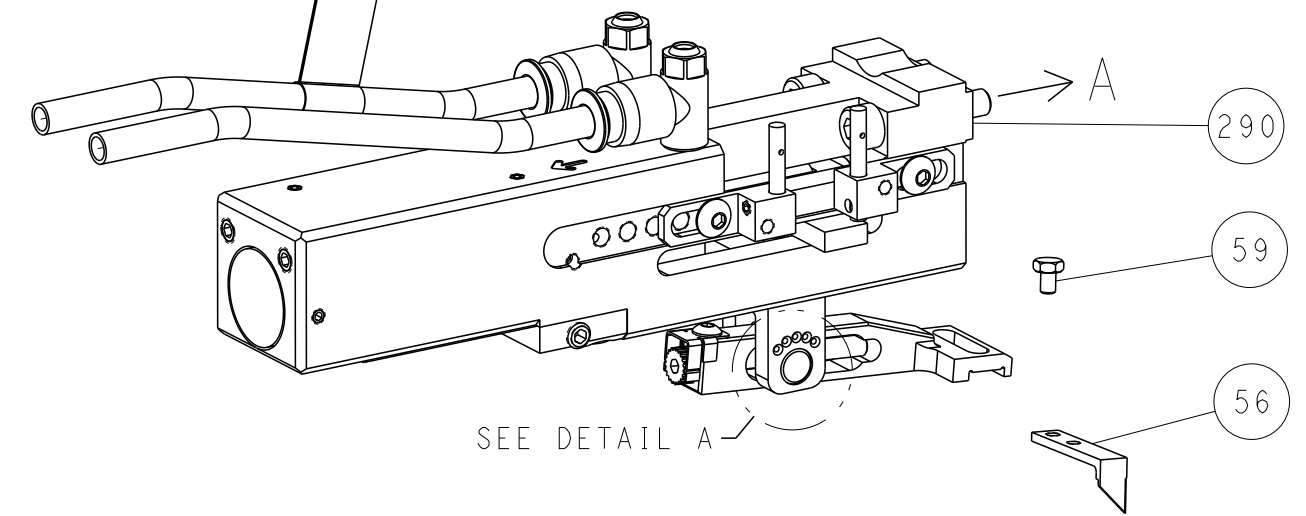

SEE DETAIL A

# CAM POSITIONS

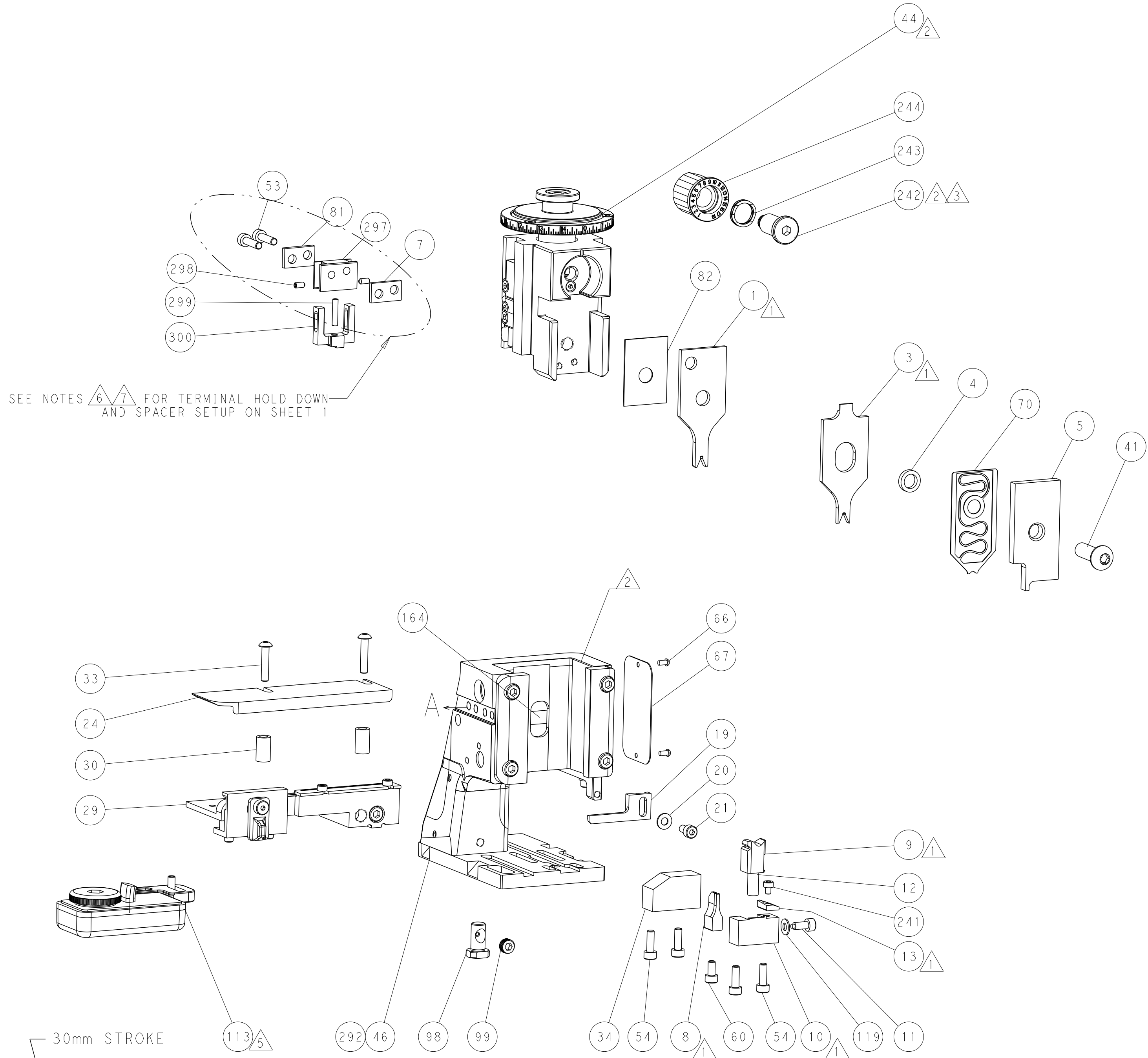
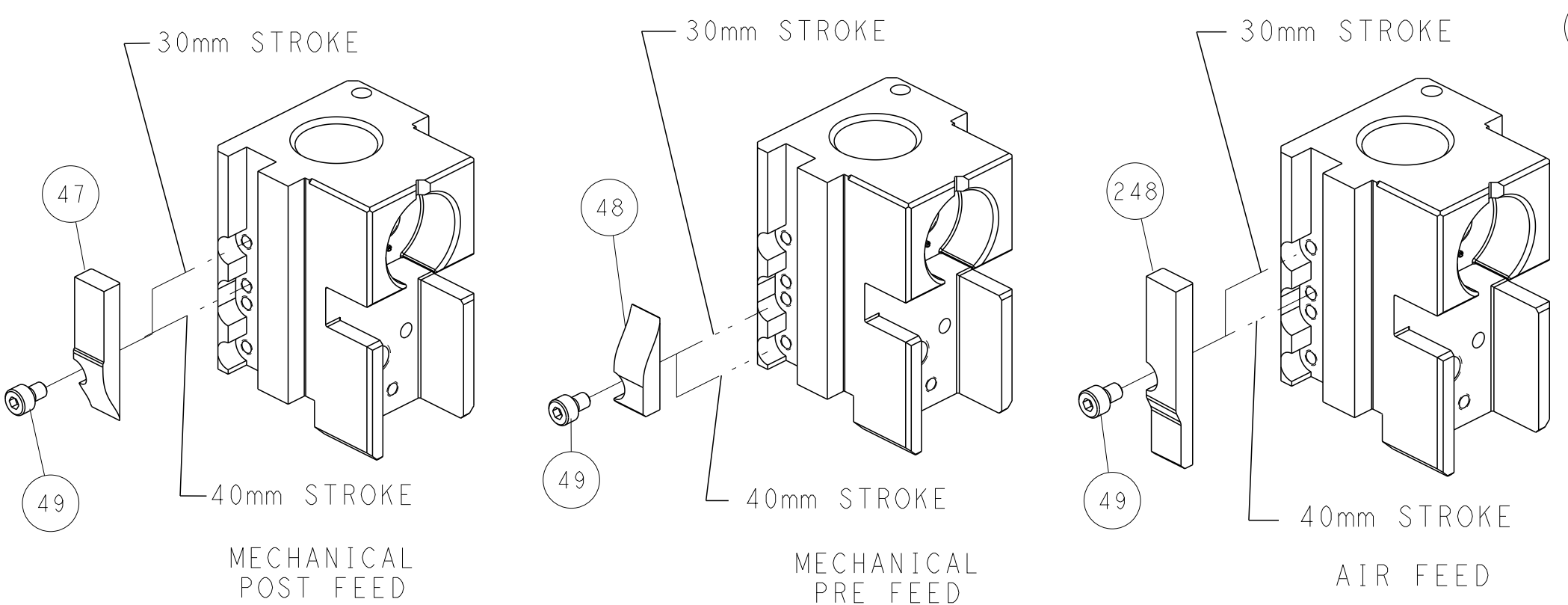

SEE NOTES 6/7 FOR TERMINAL HOLD DOWN AND SPACER SETUP ON SHEET 1

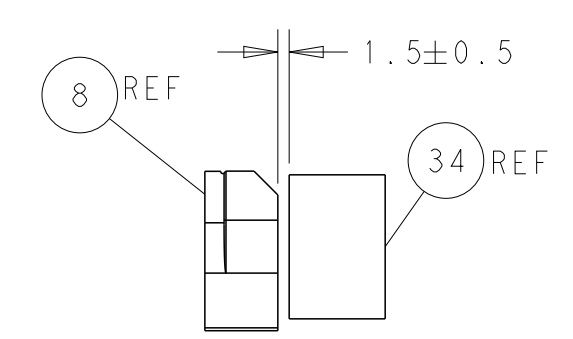

TERMINAL SUPPORT LOCATION

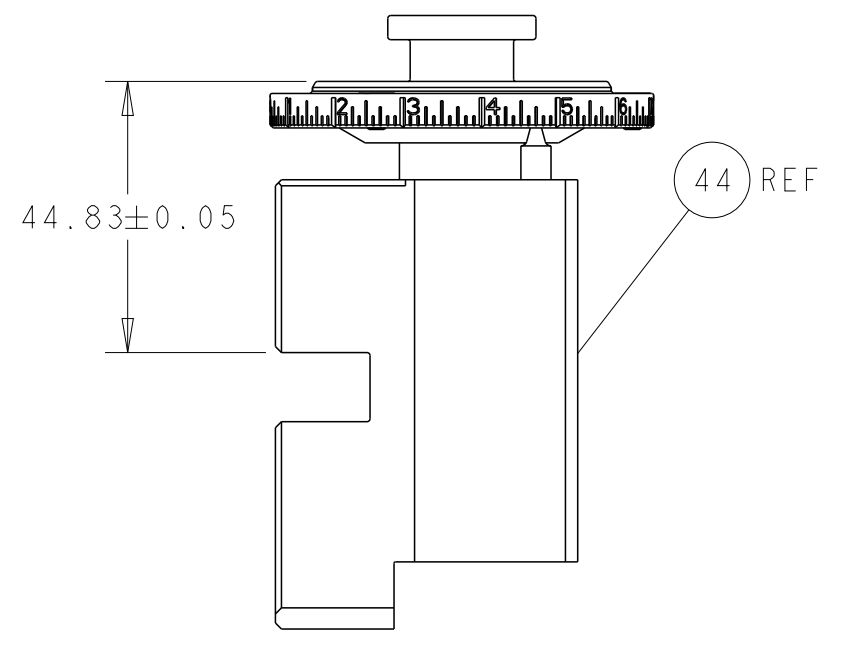

RAM SET-UP

ITEM 30 LOCATED AT FRONT HOLES

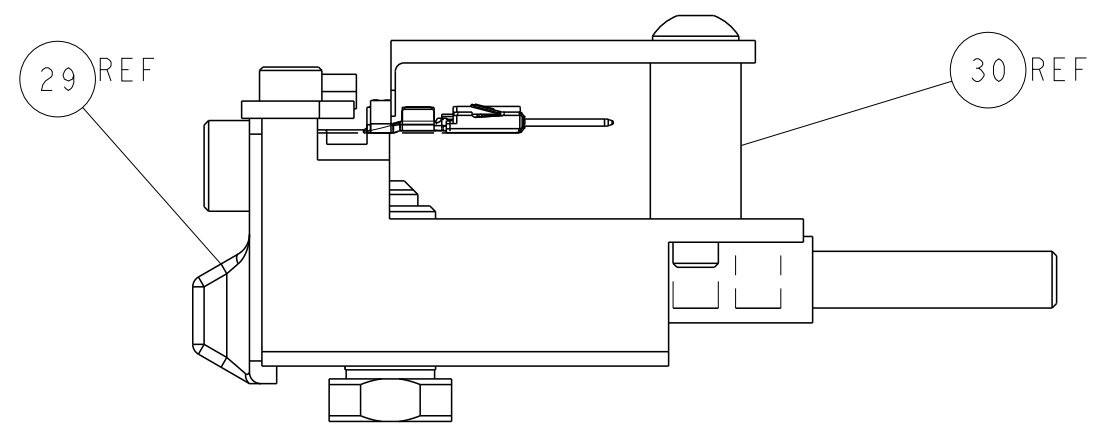

FEED TRACK POSITION GUIDE BY INSULATION BARREL

**ATLANTIC VERSION**  
 Shown on sheets 1 of 4 & 2 of 4  
 (Pacific version shown on sheets 3 of 4 & 4 of 4)

DIMENSIONS: mm 		TOLERANCES UNLESS OTHERWISE SPECIFIED: 0 PLC ± 1 PLC ± 2 PLC ± 3 PLC ± 4 PLC ± ANGLES ± FINISH		DWN B. WEAVER 31AUG2011 CHK G. HOFFNER 31AUG2011 APVD T. ELBIN 31AUG2011		NAME Ocean Side Feed Applicator SIZE CAGE CODE DRAWING NO. RESTRICTED TO A1 00779 C=2151491	
MATERIAL		WEIGHT		Customer Accessible Production Drawing		SCALE 1:2 SHEET 2 OF 4 REV V3	

PART NUMBER	REVISION	DESCRIPTION	FEED TYPE
2-2151491-1	V	FINE CRIMP HEIGHT ADJUST	MECHANICAL
2-2151491-2	V	FINE CRIMP HEIGHT ADJUST	PNEUMATIC
4-2151491-2	V	FINE CRIMP HEIGHT ADJUST	DOUBLE ACTING PNEUMATIC WITH SENSORS $\Delta$
7-2151491-7	P	CRIMP TOOLING KIT	-

PACIFIC VERSION TERMINATOR INTERFACE ADAPTER

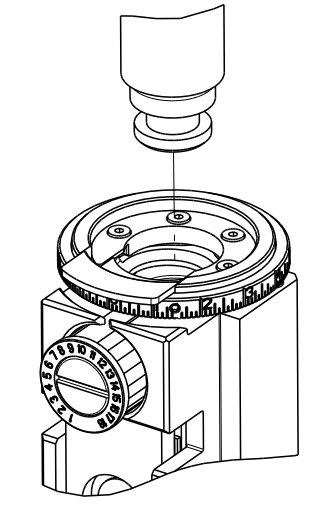

APPLICATOR DATA		
CRIMP	SIZE	TYPE
WIRE	1.40 mm [.055]	F
INSUL	2.03 mm [.080]	O
APPLICATOR INSTRUCTIONS 408-35042 $\mathbb{1}$		

TERMINAL DATA: TE TERMINAL TE CRIMP SPECIFICATION			
TERMINAL NAME: MICRO QUADLOK SYSTEM SOCKET CONTACT			
WIRE STRIP LENGTH $\mathbb{1}$		INSULATION DIAMETER RANGE	
3.35-3.65 mm [.132-.144 IN]		$\varnothing$ 1.30-1.90mm [.051-.075 IN]	
TERMINAL APPLICATION SPECIFICATION (A) 114-18021			
TERMINALS APPLIED $\Delta$			
GROUP 1 $\Delta$		GROUP 2 $\Delta$	
TE TERMINAL	TE TERMINAL	TE TERMINAL	TE TERMINAL
963715-1	963716-1	968221-1	1452013-1
963715-5	963716-2	968221-5	1-1452013-1
963715-6	1-963716-2	968221-6	5-1452013-1
1-963715-5	5-963716-1	5-968221-1	6-1452013-1
5-963715-1	5-963716-2	5-968221-5	
5-963715-5	5-963716-3	5-968221-6	
5-963715-6	6-963716-1	1241920-1	
6-963715-5	6-963716-2	5-1241920-1	

TERMINAL DATA: TE TERMINAL TE CRIMP SPECIFICATION			
TERMINAL NAME: MICRO QUADLOK SYSTEM SOCKET CONTACT			
WIRE STRIP LENGTH $\mathbb{1}$		INSULATION DIAMETER RANGE	
3.35-3.65 mm [.132-.144 IN]		$\varnothing$ 1.40-1.90 mm [.055-.075 IN]	
TERMINAL APPLICATION SPECIFICATION (A) 114-18021			
TERMINALS APPLIED $\Delta$			
GROUP 1 $\Delta$		GROUP 2 $\Delta$	
TE TERMINAL	TE TERMINAL	TE TERMINAL	TE TERMINAL
1801529-1	1703282-2		
1801529-2	5-1703282-1		
1703282-1	5-1703282-2		

TERMINAL DATA: TE TERMINAL TE CRIMP SPECIFICATION			
TERMINAL NAME: MICRO QUADLOK SYSTEM SOCKET CONTACT			
WIRE STRIP LENGTH $\mathbb{1}$		INSULATION DIAMETER RANGE	
3.35-3.65 mm [.132-.144 IN]		$\varnothing$ 1.70-1.90mm [.067-.075 IN]	
TERMINAL APPLICATION SPECIFICATION (A) 114-18021			
TERMINALS APPLIED $\Delta$			
GROUP 1 $\Delta$		GROUP 2 $\Delta$	
TE TERMINAL	TE TERMINAL	TE TERMINAL	TE TERMINAL
(A) 1379418-1	(A) 1703298-1		
(A) 1379418-2	(A) 1703298-5		
(A) 5-1379418-1	(A) 2141399-6		
(A) 5-1379418-2	(B) 2005120-1		

WIRE SIZE	CRIMP HEIGHT mm [INCH]	CRIMP HEIGHT REFERENCE SETTING $\Delta$
0.75mm2	1.07+/-0.05 [.042+/- .002]	6.3
0.35+0.35 mm2	1.07+/-0.05 [.042+/- .002]	6.3
0.22+0.35 mm2	0.94+/-0.05 [.037+/- .002]	7.6
0.50mm2	0.93+/-0.05 [.037+/- .002]	7.7
0.22+0.22 mm2	0.88+/-0.05 [.035+/- .002]	8.2

$\Delta$  THIS CRIMP PARAMETER IS PROVIDED TO MEET A CUSTOM AND UNIQUE CUSTOMER REQUIREMENT. IT HAS BEEN EVALUATED AND IS CONDITIONALLY SPECIFIED BY TE CONNECTIVITY. THIS CUSTOMIZED CRIMP PARAMETER IS NOT LISTED AS AN APPROVED APPLICATION WITHIN A TE CONNECTIVITY APPLICATION SPECIFICATION. **TE CONNECTIVITY EXPRESSLY DISCLAIMS ANY AND ALL WARRANTIES THAT THE PRODUCT WILL PERFORM SIMILARLY TO VALIDATED AND APPROVED APPLICATIONS, AS STATED WITHIN TE CONNECTIVITY APPLICATION SPECIFICATIONS, INCLUDING BUT NOT LIMITED TO IMPLIED WARRANTIES OF MERCHANTABILITY OR FITNESS FOR PARTICULAR PURPOSE.** AS SUCH, IT IS HIGHLY RECOMMENDED THAT THE CUSTOMER PERFORM FURTHER DETAILED EVALUATION TO ASSESS PRODUCT PERFORMANCE IN THE SPECIFIC APPLICATION.

**\*WARNING**  
ON INSTALLATION, SET WIRE DISC TO CRIMP HEIGHT REFERENCE SETTING FOR LARGEST WIRE SIZE. CRIMP HEIGHT REFERENCE SETTINGS GREATER THAN THE VALUE SHOWN MAY CAUSE DAMAGE TO THE CRIMP TOOLING, REFER TO THE INSTRUCTION SHEET FOR PROPER SETUP AND ADJUSTMENTS.

ENTRY LEVEL APPLICATOR		ITEM SUBSTITUTION LIST		
PART NUMBER	SAME AS	ITEM	ITEM DESCRIPTION	SUBSTITUTE PART NUMBER
8-2151491-1	2151491-1	1	WIRE CRIMPER	1-2234020-6
8-2151491-2	2151491-2	3	INSULATION CRIMPER	1-1803599-9
9-2151491-1	2-2151491-1	46	BASIC SUB -ASSEMBLY	1803940-9
9-2151491-2	2-2151491-2	141	BASIC SUB -ASSEMBLY	1-1803940-0
			LUBRICATOR	DELETE

LOC	DIST	REVISIONS					
A	66	P	LTN	DESCRIPTION	DATE	OWN	APVD
		-		SEE SHEET 1			

-	1	1	1	1803945-2	TONKER		300
-	1	1	1	22278-9	SPRING, COMPRESSION		299
-	2	2	2	4-18032-3	SCR, SET, FLT PNT, M3 X 6.0		298
-	1	1	1	1803944-1	SPACER, TONKER		297
-	1	-	-	2844950-1	AIR FEED MODULE		290
-	1	1	1	2119082-5	CAM, SNAIL, INSULATION ADJUSTMENT		244
-	1	1	1	2079764-1	WASHER, WAVE SPRING, CREST-TO-CREST		243
-	1	1	1	2119083-1	RETAINER, INSULATION DIAL		242
-	1	1	1	7-18023-7	SCR, SKT HD CAP M3 X 4.0		241
-	-	-	-	2119580-1	MECHANICAL FEED ASSEMBLY		239
-	-	-	-	2844940-1	AIR FEED MODULE		238
-	REF	REF	REF	994970-2	COUNTER, MAGNETIC		164
-	-	-	-	2119641-2	FEED CAM, AIR FEED		151
-	1	1	1	2168083-8	SCR, SKT HD CAP, RoHS, M4 X 16		144
-	4	4	4	2168083-9	SCR, SKT HD CAP, RoHS, M4 X 20		143
-	-	-	-	2119653-2	FEED CAM, POST FEED		142
-	1	1	1	1-1803583-0	APPLICATOR BASIC ASSEMBLY, SF		141
-	1	1	1	1803516-1	RAM ASSEMBLY, SF PACIFIC		140
-	1	1	1	1-18028-2	WASHER, FLAT, REG M4		119
-	1	1	1	2119955-1	ASSY, LUBRICATOR, SIDE FEED		113
-	1	1	1	2844908-1	SCREW, LOCKING		99
-	1	1	1	2844907-1	POST, LOCKING		98
-	1	1	1	455888-6	SPACER, CRIMPER		82
-	1	1	1	240641-6	SPACER		81
-	1	1	1	1803607-3	DOCUMENTATION PACKAGE		71
-	1	1	1	2119791-9	DEPRESSOR, WIRE		70
-	1	1	1	2119740-1	TAG IDENTIFICATION		67
-	2	2	2	2168078-1	SCREW, DRIVE, RH, RoHS, 2 x .188		66
-	1	1	1	5-18022-5	SCR, HEX HD CAP, M4 X 6.0		59
-	1	1	1	1338685-1	PAWL, FEED		56
-	2	2	2	2168083-8	SCR, SKT HD CAP, RoHS, M4 X 16		53
-	-	-	-	18023-9	SCR, SKT HD CAP M4 X 6.0		49
-	-	-	-	2119652-1	FEED CAM, PRE FEED		48
-	1	1	1	1803602-1	SCR, BHSC, RoHS (M8 X 25)		41
-	1	1	1	1752356-6	SUPPORT, TERMINAL		34
-	2	2	2	2079383-5	SCR, BHSC, RoHS (M4 X 20)		33
-	2	2	2	2-2844962-4	SPACER, CYLINDRICAL, STRIP GUIDE		30
-	1	1	1	2844992-1	ASSEMBLY, STRIP GUIDE		29
-	1	1	1	1320928-2	STRIP GUIDE		24
-	1	1	1	2168083-2	SCR, SKT HD CAP, RoHS, M4 X 8.0		21
-	1	1	1	1-18028-2	WASHER, FLAT, REG M4		20
-	1	1	1	2119533-1	STRIPPER, SIDE FEED		19
-	1	1	1	2119806-1	INSERT, SHEAR		13
-	1	1	1	3-22280-3	SPRING, COMPRESSION		12
-	1	1	1	1-356885-4	STOP, SHEAR		11
-	1	1	1	2119805-1	SHEAR HOLDER, FRONT		10
-	1	1	1	1803095-3	FLOATING SHEAR, FRONT		9
-	1	1	1	1-1338690-1	ANVIL, COMBINATION .055		8
-	1	1	1	3-240641-7	SPACER		7
-	1	1	1	2119757-4	DEPRESSOR, SHEAR		5
-	1	1	1	238011-9	BLOCK, CRIMPER SPACER		4
-	1	1	1	2-1633966-9	CRIMPER, INSULATION O		3
-	1	1	1	1-1633773-6	CRIMPER, WIRE, STEP		1

- $\mathbb{1}$  RECOMMENDED SPARE PARTS  $\mathbb{1}$
- $\Delta$  REFER TO SUPPLIED INSTRUCTION SHEET FOR CLEANING, LUBRICATION & STORAGE OF APPLICATOR.
- $\Delta$  APPLY PART NUMBER 2-23419-6 LOCTITE TO THREADS OF ITEM 242.
- $\Delta$  CRIMP HEIGHT REFERENCE SETTING WAS THE SETTING USED WHEN THE APPLICATOR WAS QUALIFIED AT THE FACTORY. ADJUSTMENT MAY BE NECESSARY WHEN RUNNING APPLICATOR IN THE FIELD.
- $\Delta$  TERMINAL LUBRICANT IS RECOMMENDED.
- $\Delta$  POSITION THE HOLD DOWN, ITEM 297, AS SHOWN FOR GROUP 1 TERMINALS.

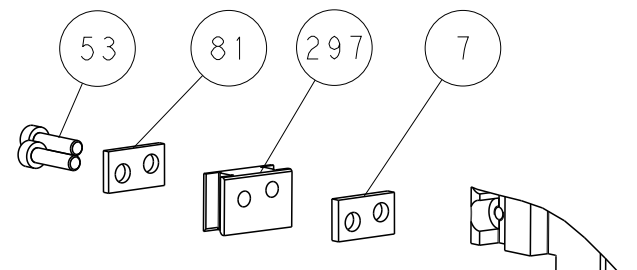

- $\Delta$  POSITION THE HOLD DOWN, ITEM 297, AS SHOWN FOR GROUP 2 TERMINALS.

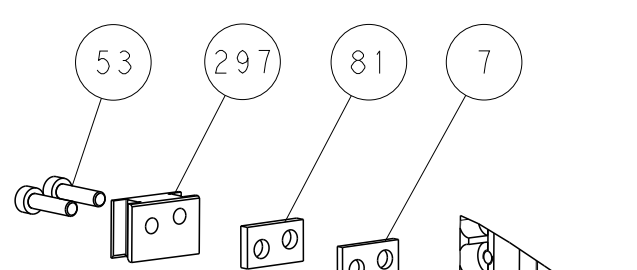

- 8. UNLESS SPECIFIED OTHERWISE TORQUE VALUES SHALL BE USED PER DOCUMENT, 101-35000.
- $\Delta$  THIS APPLICATOR IS EQUIPPED WITH THE DOUBLE ACTING FEED WITH SENSORS AND IS APPLICATION SPECIFIC AND DOES NOT REQUIRE ITEMS 49 & 151.

PACIFIC VERSION  
Shown on sheets 3 of 4 & 4 of 4  
(Atlantic version shown on sheets 1 of 4 & 2 of 4)

DIMENSIONS:		TOLERANCES UNLESS OTHERWISE SPECIFIED:		MATERIAL:		FINISH:		WEIGHT:		SCALE:	
mm	0 PLC	±									
	1 PLC	±									
	2 PLC	±									
	3 PLC	±									
	4 PLC	±									
	ANGLES	±									

CHK	DATE	NAME	SIZE	CAGE CODE	DRAWING NO	RESTRICTED TO
WEAVER	31AUG2011	TE Connectivity	A1	00779	2151491	
HOFENER	31AUG2011	Harrisburg, PA 17105-3608				
ELBIN	31AUG2011	Ocean Side Feed				
		Applicator				

Customer Accessible Production Drawing SCALE 1:2 SHEET 3 OF 4 REV V3

LOC		DIST		REVISIONS			
A	66	P	LTM	DESCRIPTION	DATE	DWN	APVD
		-	-	SEE SHEET 1	-	-	-

# FEED TYPE MECHANICAL

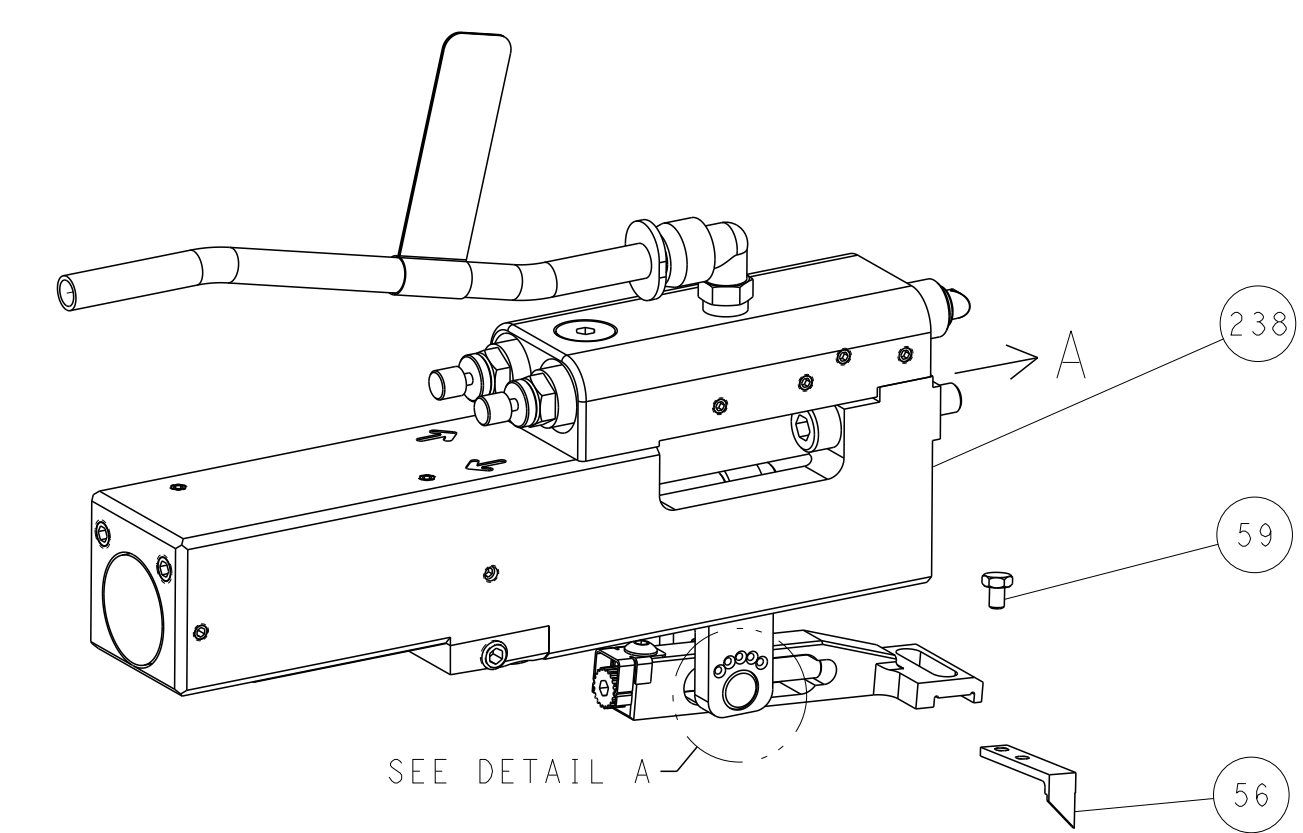
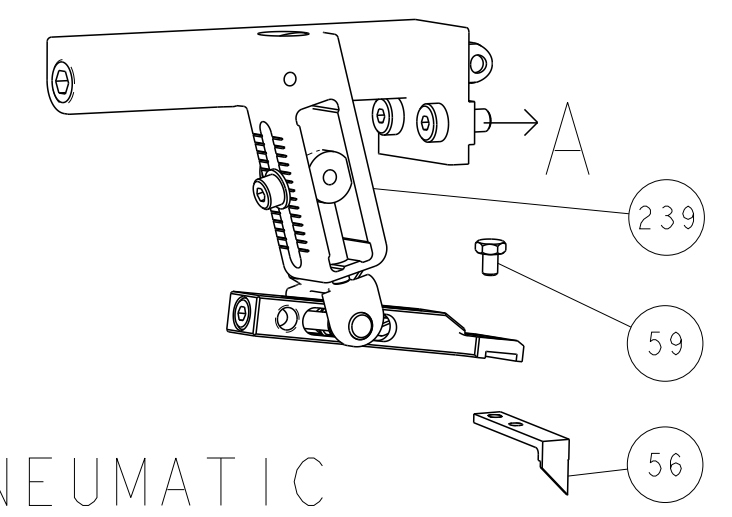

FEED SPRING SETTING POSITION (SHOWN FROM REAR SIDE)

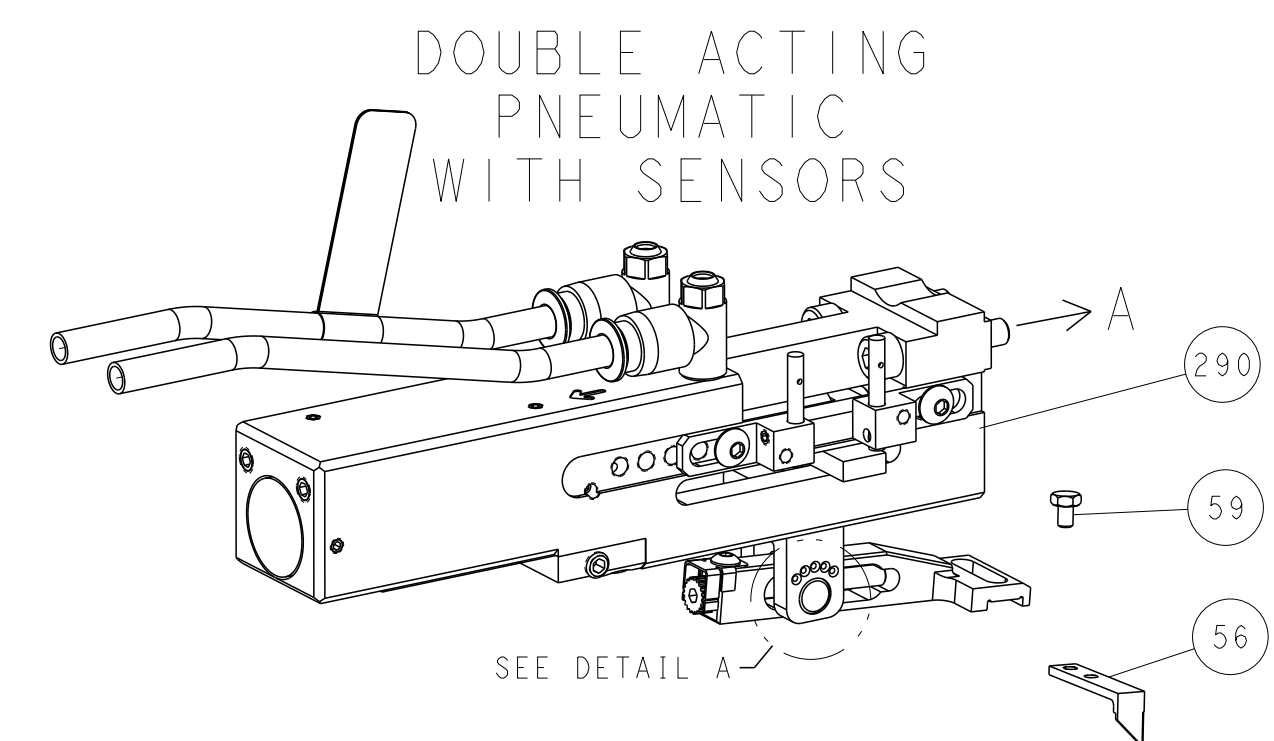
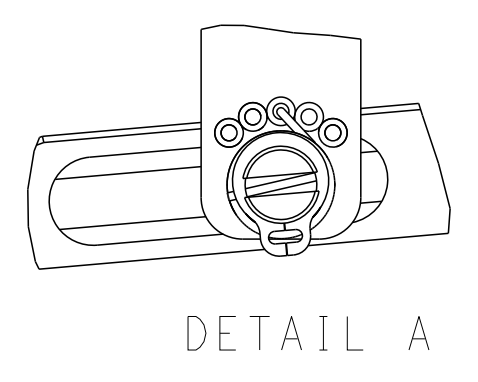

# CAM POSITIONS

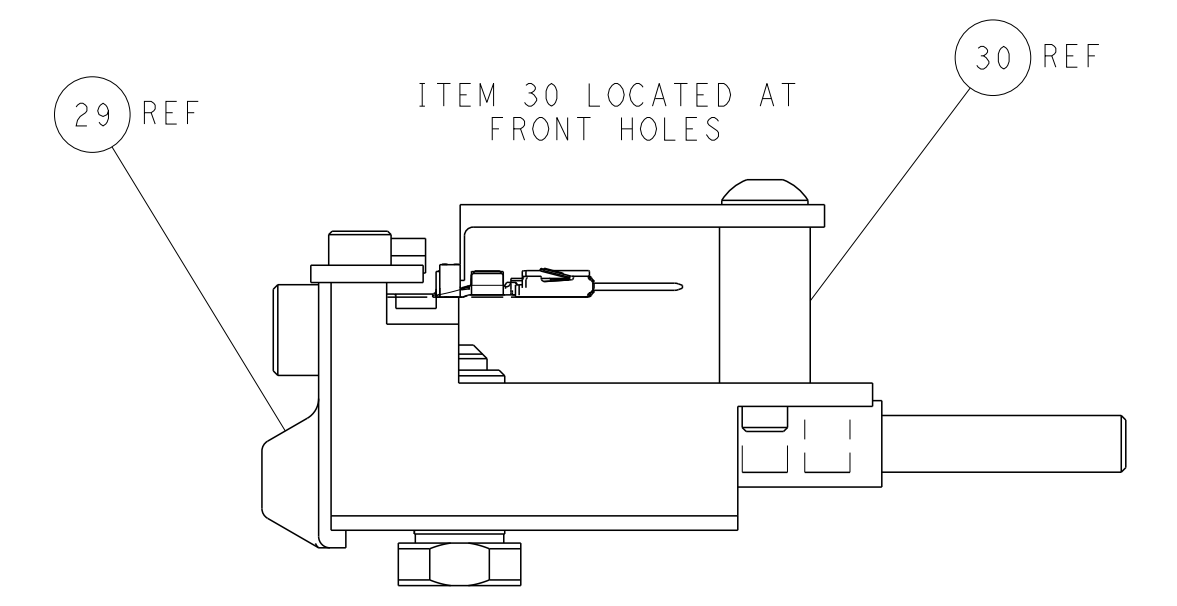
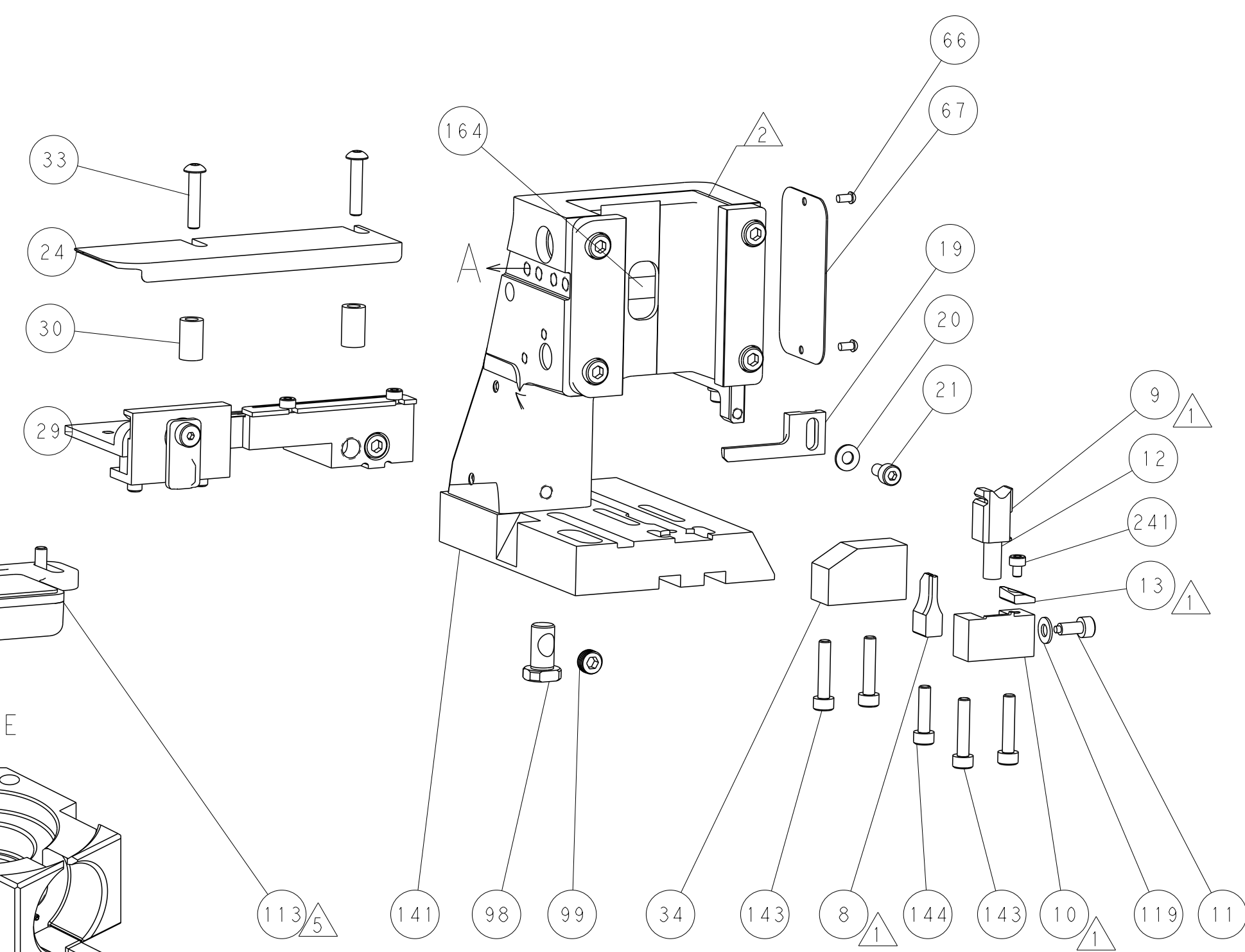
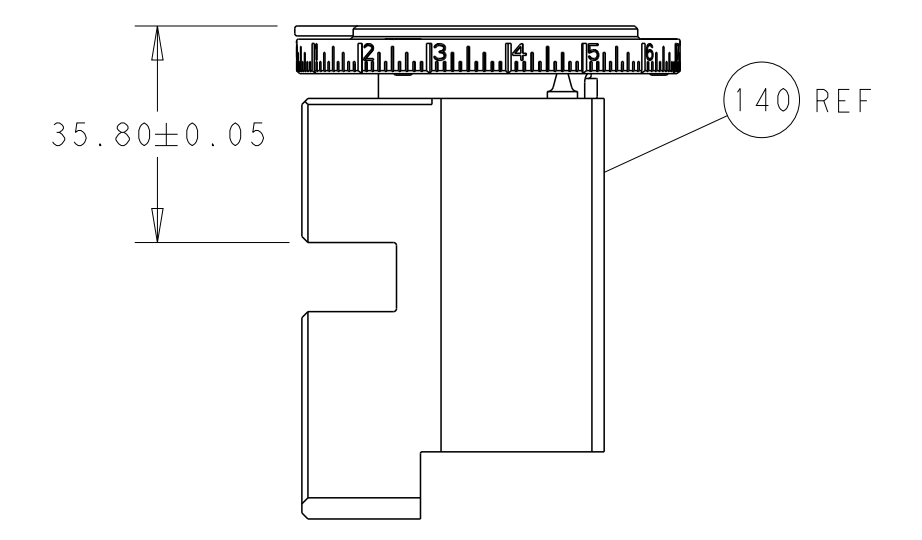
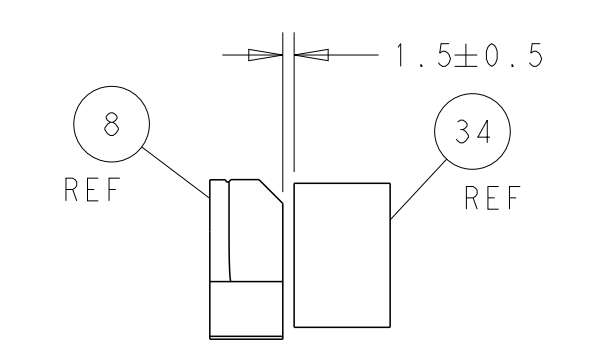
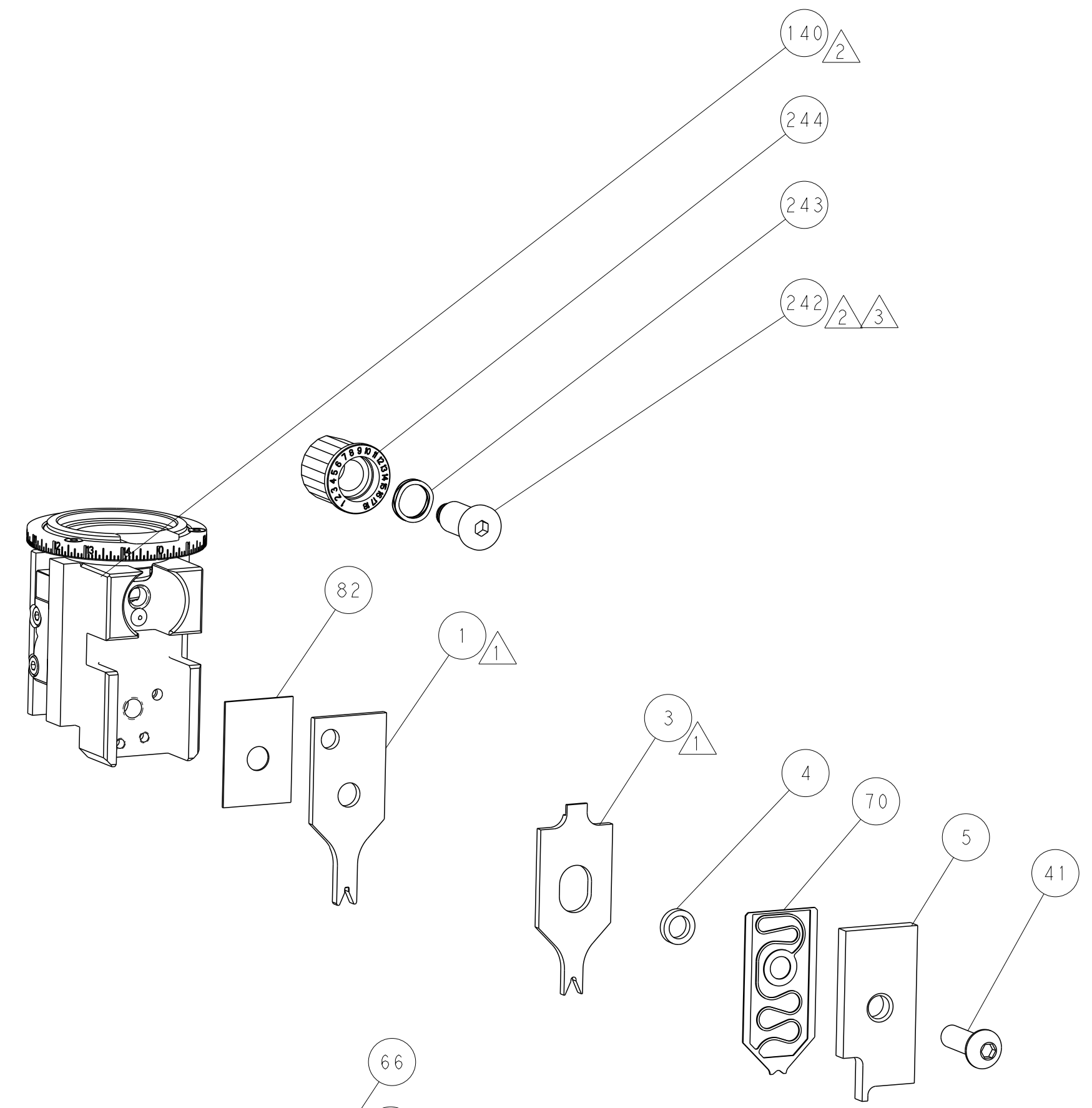
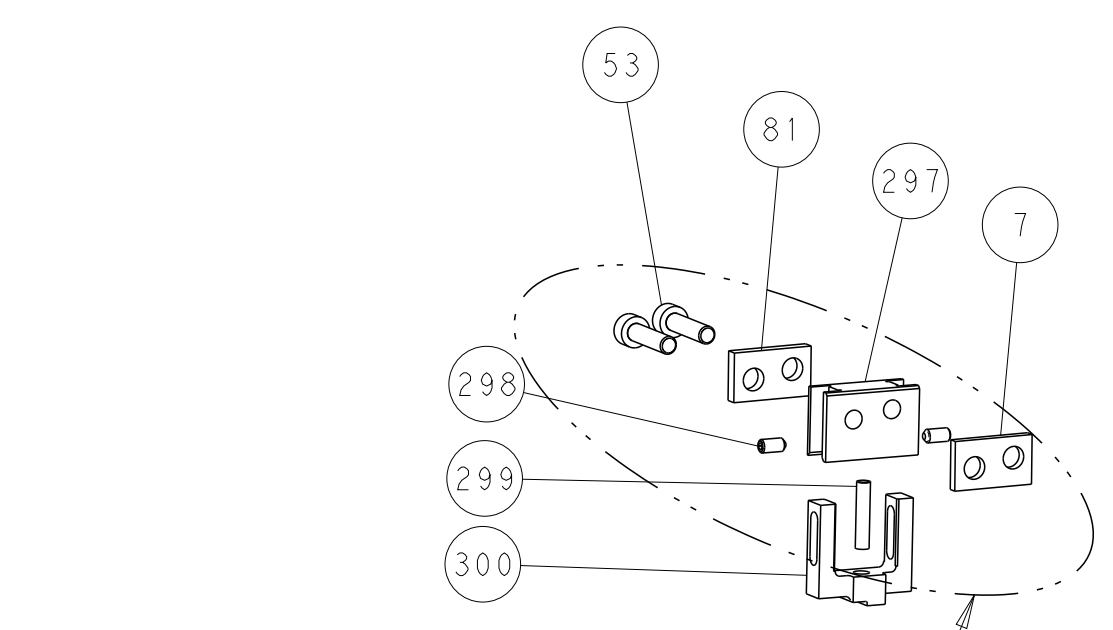
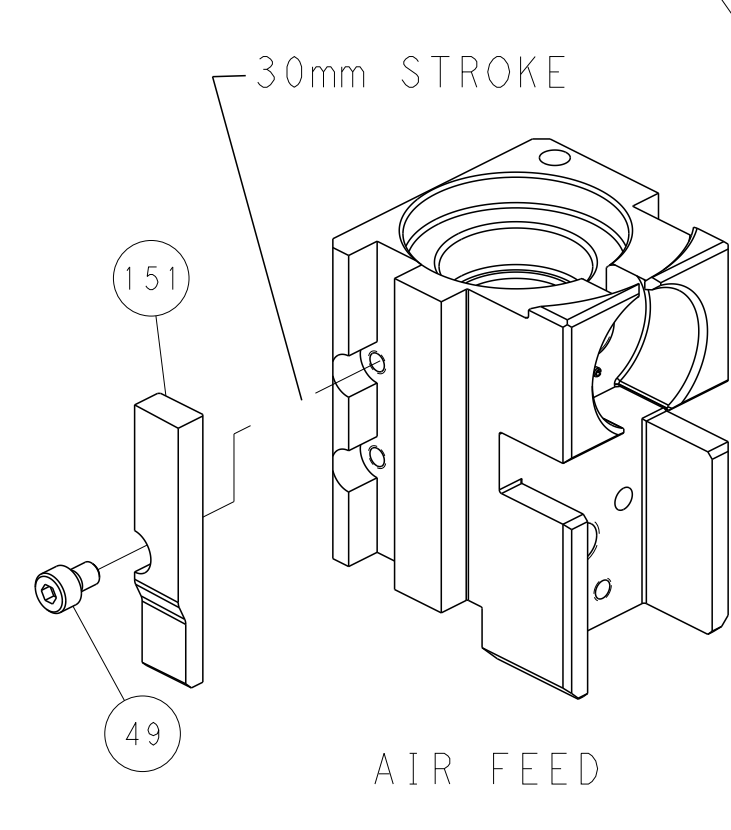
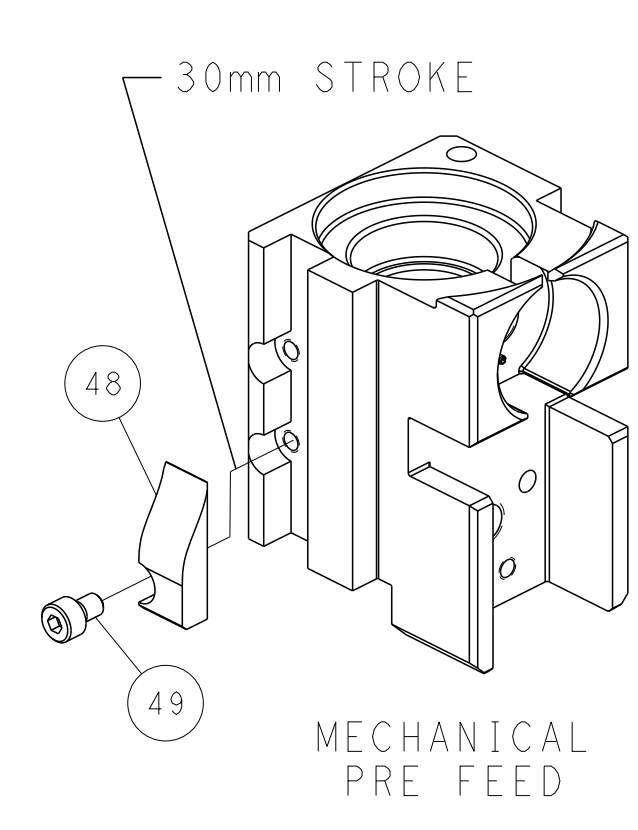
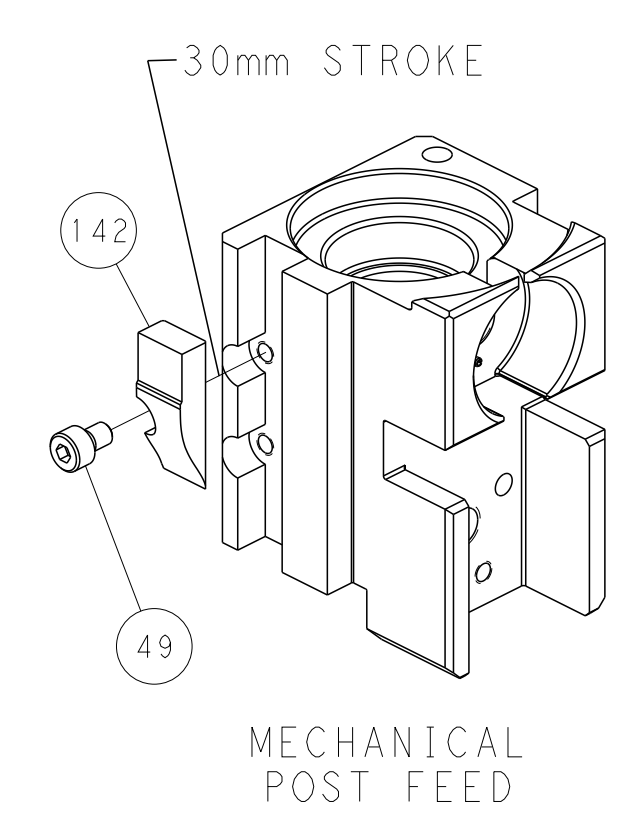

**PACIFIC VERSION**  
 Shown on sheets 3 of 4 & 4 of 4  
 (Atlantic version shown on sheets 1 of 4 & 2 of 4)

DIMENSIONS:		TOLERANCES UNLESS OTHERWISE SPECIFIED:		DWN B. WEAVER 31AUG2011		TE Connectivity	
mm	0 PLC ±	1 PLC ±	2 PLC ±	3 PLC ±	4 PLC ±	5 PLC ±	Harrisburg, PA 17105-3608
	ANGLES	FINISH		CHK G. HOFFNER	APVD T. ELBIN 31AUG2011	NAME Ocean Side Feed Applicator	
MATERIAL		WEIGHT		SIZE	CAGE CODE	DRAWING NO	RESTRICTED TO
				A1	00779	©=2151491	
Customer Accessible Production Drawing				SCALE	1:2	SHEET	4 OF 4
				REV	3		