

Technical Data Sheet

Rosenberger

RPC-N
75 Ω

Calibration Adaptor
Plug/Plug

P5S121-S21S3

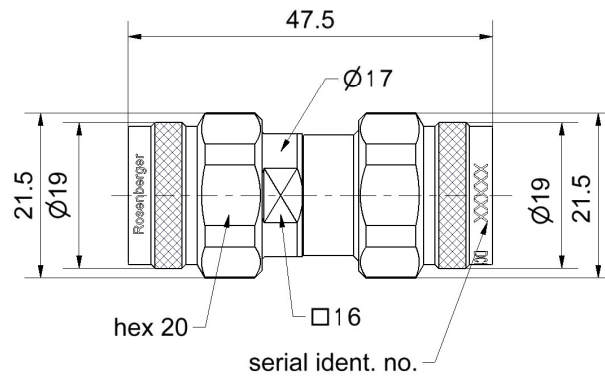

All dimensions are in mm; tolerances according to ISO 2768 m-H

Interface

According to IEC 61169-16

Documents

Application note AN001 "Calibration Services"

Material and plating

Connector parts

Center conductor
Outer conductor
Coupling nut
Dielectric

Material

CuBe
Stainless steel
Stainless steel
PS

Plating

Gold, min. 1.27 μm , over nickel
Passivated
Passivated

RPC-N
75 Ω

Calibration Adaptor
Plug/Plug

P5S121-S21S3

Electrical data

Frequency range	DC to 18 GHz
Return loss	≥ 36 dB, DC to 4 GHz
	≥ 25 dB, 4 GHz to 12 GHz
	≥ 20 dB, 12 GHz to 18 GHz

Mechanical data

Mating cycles	≥ 500
Maximum torque	1.70 Nm
Recommended torque	1.10 Nm
Gauge	5.28 mm to 5.36 mm

General standard definitions

For proper operation the vector network analyzer (VNA) needs a model describing the electrical behaviour of this calibration standard. The different models, units, and terms used will depend on the VNA type and they will have to be entered into the VNA. All values are based on typical geometry and plating.

Offset Z_0 / Impedance / Z_0	75 Ω
Offset Delay	155.441 ps
Length (electrical) / Offset Length	46.60 mm
Offset Loss	1.20 GΩ/s
Loss	0.0108 dB/√GHz

Environmental data

Operating temperature range ¹	+20 °C to +26 °C
Rated temperature range of use ²	0 °C to +50 °C
Storage temperature range	- 40 °C to +85 °C

RoHS compliant

¹ Temperature range over which these specifications are valid.

² This range is underneath and above the operating temperature range, within the calibration adaptor is fully functional and could be used without damage.

Technical Data Sheet

Rosenberger

RPC-N
75 Ω

Calibration Adaptor
Plug/Plug

P5S121-S21S3

Declaration of calibration options

Factory Calibration

Standard delivery for this calibration standard includes a Factory Calibration. The Calibration Certificate issued reports individual calibration results, traceable to national / international standards. Model based standard definitions are reported in an Agilent/Keysight, Rohde & Schwarz and Anritsu compatible VNA format.

Accredited Calibration

Optional this calibration standard can be delivered with an Accredited Calibration (DAkkS) up to 12 GHz having the highest confidence in the traceability. The DAkkS Calibration Certificate issued reports individual calibration results in a complex format, traceable to national / international standards. Model based standard definitions are individually optimized and reported in an Agilent/Keysight, Rohde & Schwarz and Anritsu compatible VNA format as well as in a dense data set needed for data based standard definitions. The uncertainties are smaller than in a Factory Calibration.

For further, more detailed information see application note AN001 on the Rosenberger homepage.

Calibration interval

Recommendation 12 months

Packing

Standard 1 pce in box
Weight 64.0 g/pce

While the information has been carefully compiled to the best of our knowledge, nothing is intended as representation or warranty on our part and no statement herein shall be construed as recommendation to infringe existing patents. In the effort to improve our products, we reserve the right to make changes judged to be necessary.

For the installation of the electrotechnical equipment, particular electrotechnical expertise is required.



Draft	Date	Approved	Date	Rev.	Engineering change number	Name	Date
Marion Striegler	11.08.21	Lars Ramtke	22.04.22	b00	22-1011	David d'Argent	22.04.22

Rosenberger Hochfrequenztechnik GmbH & Co. KG P.O.Box 1260 D-84526 Tittmoning Germany www.rosenberger.de	Tel. : +49 8684 18-0 Email : info@rosenberger.de	Page 3 / 3
--	---	---------------