

PROJ	LOC	Q1ST	P	F	ZONE	LTR	DESCRIPTION	DATE	APPD
5327	DF	F0					REV & REDWN PER DF-5332	A. G.	12-91
							REV & REDWN PER DF-6730	WDK	3-12-93
							REV PER 0600-1388-93	TA	5-4-94
							REV PR 0600-5606-96	TT	08-97

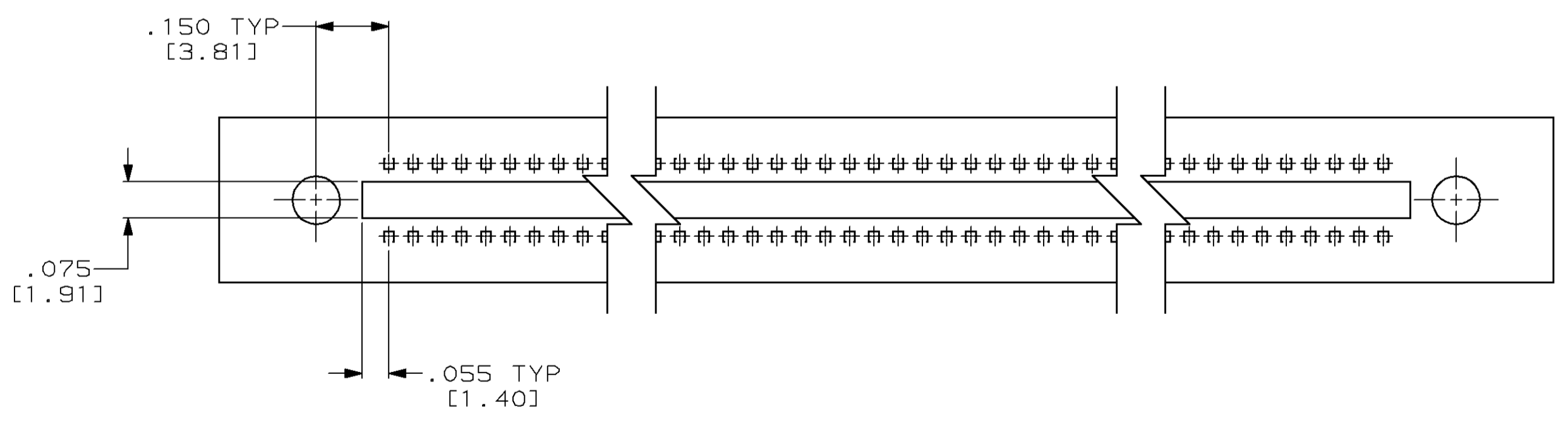
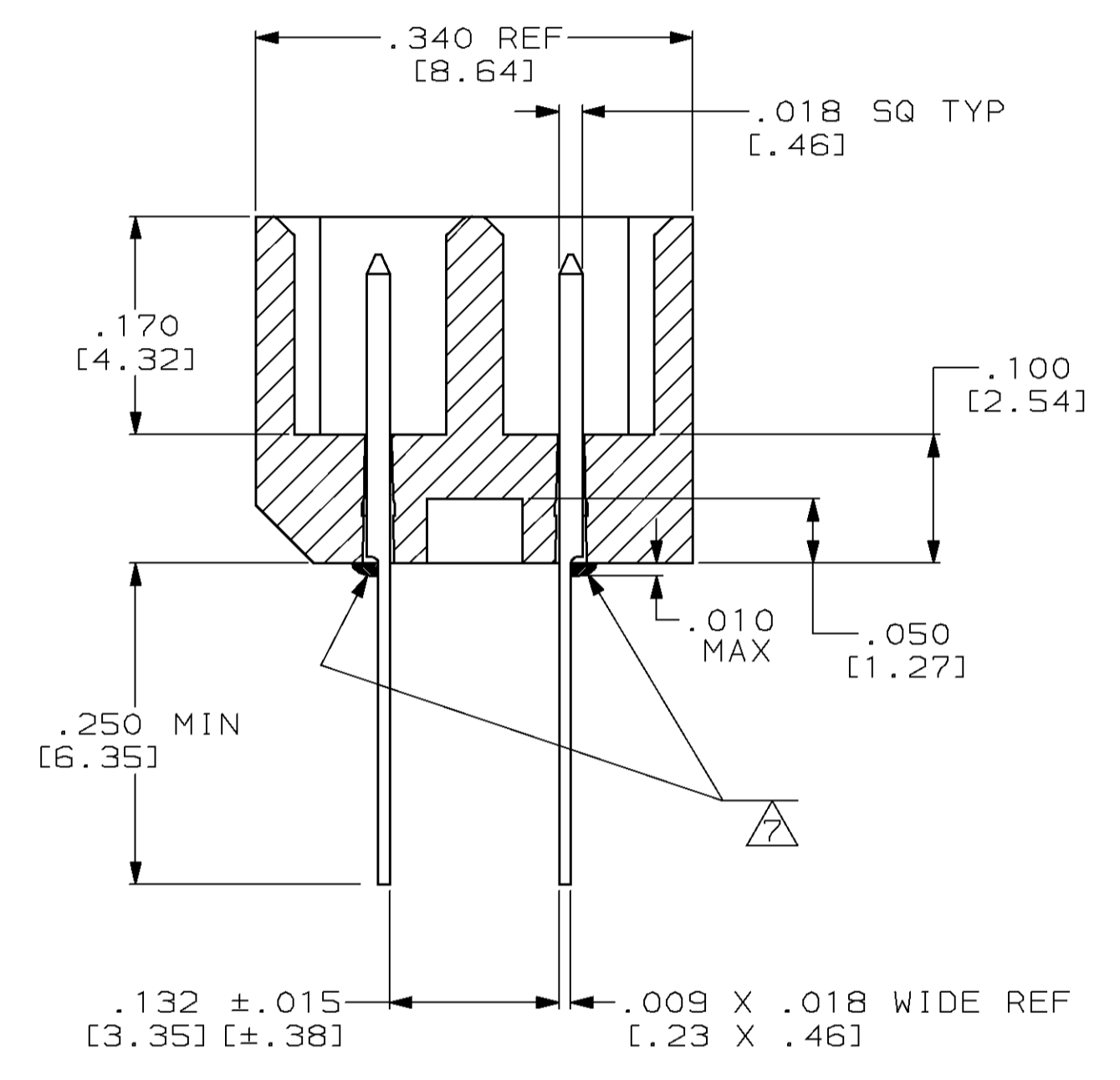
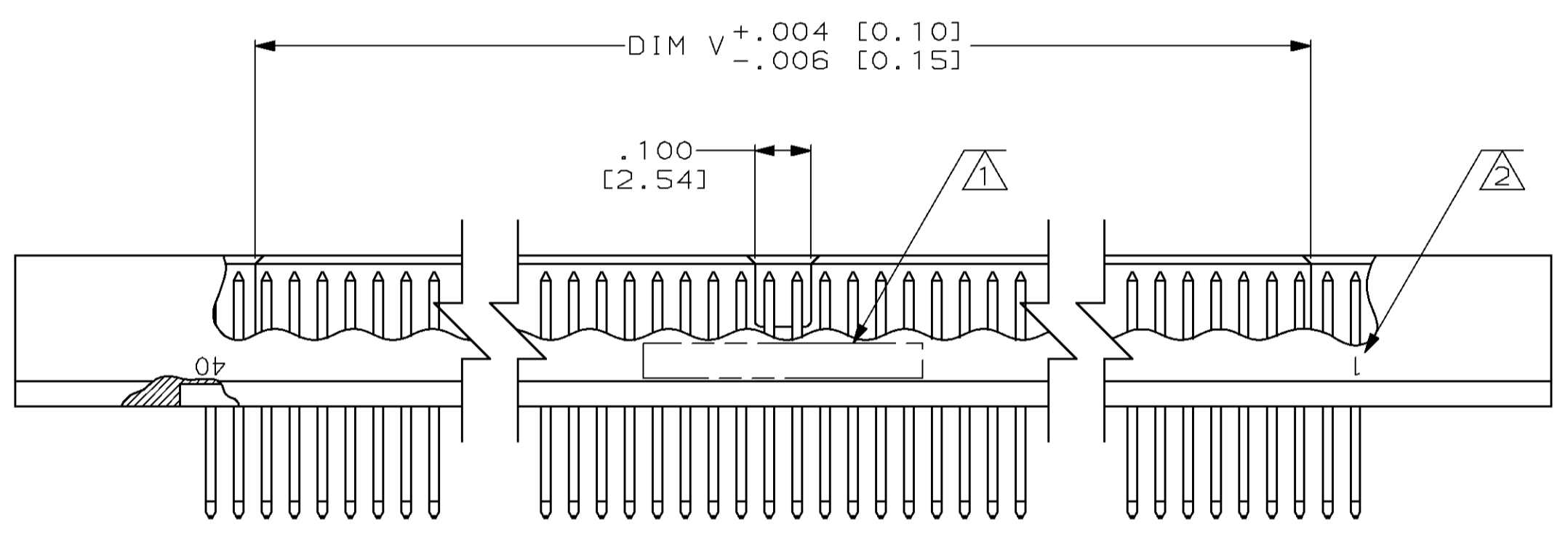
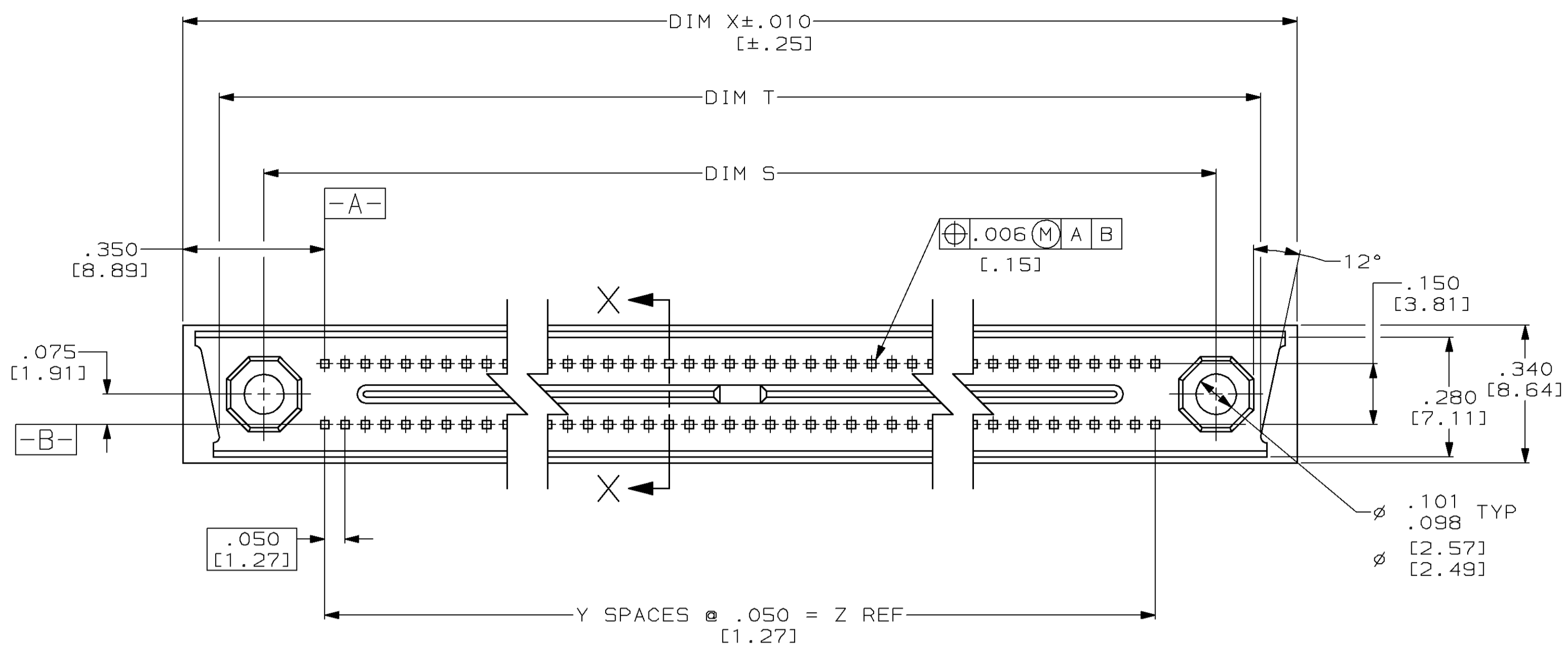

1.950 [49.53]	39	2.650 [67.31]	1.790 [45.47]	2.470 [62.74]	2.250 [57.15]	80	533642-2
OBSOLETE 2.450 [62.23]	49	3.150 [80.01]	2.290 [58.17]	2.970 [75.44]	2.750 [69.85]	100	533642-1
DIM Z	DIM Y	DIM X	DIM V	DIM T	DIM S	NUMBER OF CONTACTS	PART NUMBER

- 1. AMP, PART NUMBER & DATE CODE MARKED IN THIS APPROXIMATE AREA.
- 2. NUMBERS INDICATING END POSITIONS MARKED THIS SIDE ONLY.
- 3. MEET ALL APPLICABLE REQUIREMENTS OF MIL-C-55302.
- 4. HOUSING MATERIAL: LIQUID CRYSTAL POLYMER PER MIL-M-24519, GLCP-30F; COLOR: GRAY.
- 5. CONTACT MATERIAL: BRASS.
- 6. FINISH: .000050 GOLD ON CONTACT MATING AREA OVER NICKEL, TIN-LEAD PLATED TAILS.
- 7. EPOXY ADDED TO BOTTOM WHERE CONTACT TAILS EXIT HOUSING.
- 8. A SPACER OF .020 - .025 THICK MUST BE USED BETWEEN BOARD AND CONNECTOR EARS WHEN BEING VERTICALLY MOUNTED TO THE PC BOARD.

DO NOT SCALE PRINT. UNLESS SPECIFIED DIMENSIONS IN INCHES [mm] TOLERANCES ON:

- 2 PLC DEC ± .005 [0.13]
- 3 PLC DEC ± .005 [0.13]
- ANGLES ± 0° 30'

MATERIAL:

FINISH:

DR 2-20-91 T. SHUEY  
 CHK 12-31-91 D. GUTTER  
 APPD 12-31-91 D. GUTTER  
 APPD 12-31-91 D. GUTTER

PRODUCT SPEC: -

APPLICATION SPEC: -

WEIGHT: -

**AMP** AMP Incorporated  
 Harrisburg, PA 17105-3608

NAME: ASSEMBLY, PIN HEADER, MINI-BOX, VERTICAL WITH STRAIGHT TAILS

SIZE: D 00779  
 CAGE CODE: 00779  
 DRAWING NO: 533642  
 SCALE: 4:1  
 SHEET: 1 OF 1