

P	LTR	DESCRIPTION	DATE	DWN	APVD
	A	RELEASED FOR PRODUCTION	10FEB2023	DM	CB
	AI	ADDING PRODUCT DATA	07MAR2023	DM	CB

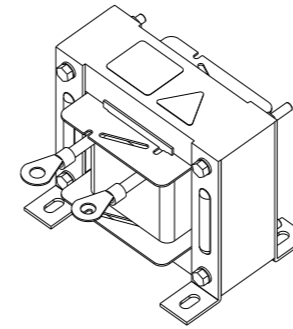

NOMINAL OPERATING VOLTAGE (VAC)	230
RATED OPERATING VOLTAGE (VAC)	250
FREQUENCY (Hz)	50 / 60
RATED CURRENT (AMPS)	100
OP. TEMP. RANGE @ RATED CURRENT	-45°C to +45°C
RATED POWER @ 230VAC (kW)	20.70
RATED POWER @ 230VAC (HP)	27.75
IMPEDANCE @ 230VAC (%)	4
INDUCTANCE, NOMINAL (mH)	0.293
POWER OVERLOAD, 1 MINUTE EVERY HOUR	1.6
VOLTAGE WITHSTAND 1 MINUTE (kVAC)	2
POLLUTION DEGREE	PD2
COOLING	NATURAL
PROTECTION CLASS	IP00
INSULATION CLASS	N
STORAGE TEMPERATURE RANGE (°C)	-45°C to +100°C
CLIMATIC CATEGORY	45/100/21
DESIGN CORRESPONDING TO	EN61558-2-20, EN60076-6, UL61800-5-1

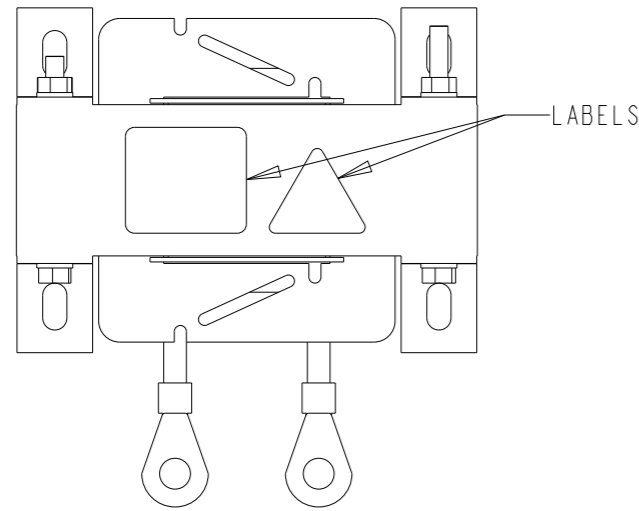
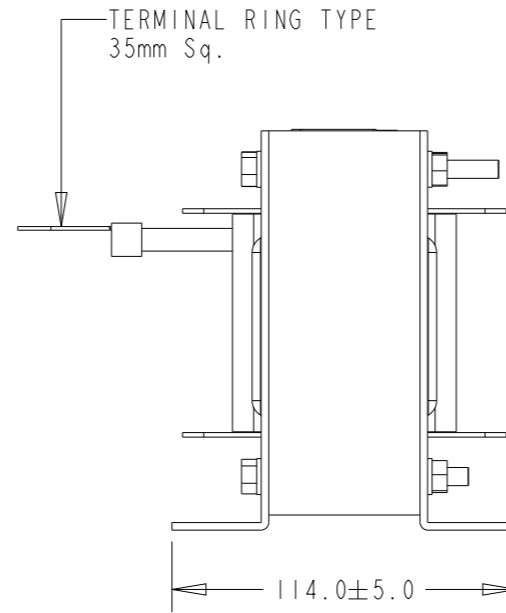
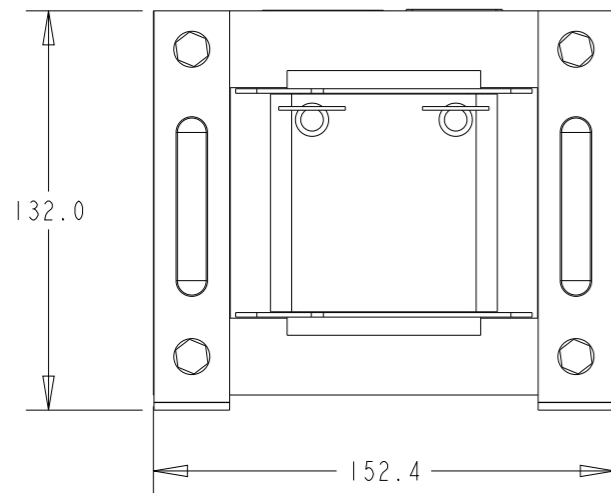

PRODUCT DESIGN NOTE

DESIGN IN ACCORDANCE WITH UL 508

DE-RATING FORMULAE FOR OPERATION ABOVE 45°C AMBIENT CONDITIONS:

$$I = I_n \sqrt{\frac{100 - T_{a\ new}}{100 - 45}}$$

TYPICAL CIRCUIT DIAGRAM

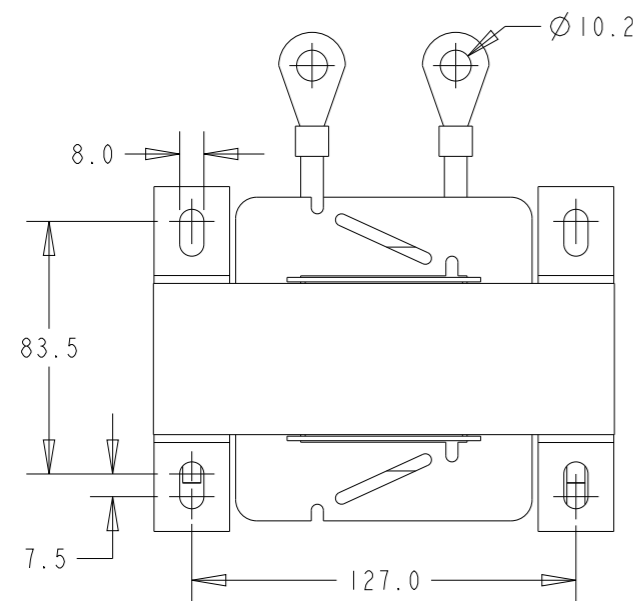
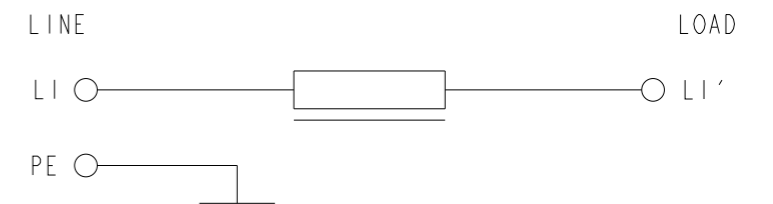

RoHS COMPLIANT

THIS DRAWING IS A CONTROLLED DOCUMENT.		DWN C. BOLLE	05OCT2022		
DIMENSIONS: mm		CHK C. BOLLE	05OCT2022		
TOLERANCES UNLESS OTHERWISE SPECIFIED:		APVD L. RAJ	05OCT2022		
0 PLC ±- 1 PLC ±0.1 2 PLC ±0.01 3 PLC ±0.001 4 PLC ±0.0001 ANGLES ±-		NAME RPO-1-100	SINGLE LINE REACTOR		
MATERIAL		PRODUCT SPEC	-	APPLICATION SPEC	-
FINISH		WEIGHT	-	SIZE	A3
-		CUSTOMER DRAWING		CAGE CODE	00779
-		SCALE		DRAWING NO	G-1-2432408-6
-		SHEET		RESTRICTED TO	-
-		OF		REV	AI