

THIS DRAWING IS UNPUBLISHED. RELEASED FOR PUBLICATION
 © COPYRIGHT - TE Connectivity Ltd. ALL RIGHTS RESERVED.

REVISIONS				
P	LTR	DESCRIPTION	DATE	APVD
E1		REVISED PER ECO-18-018098	19NOV2018	RS DR

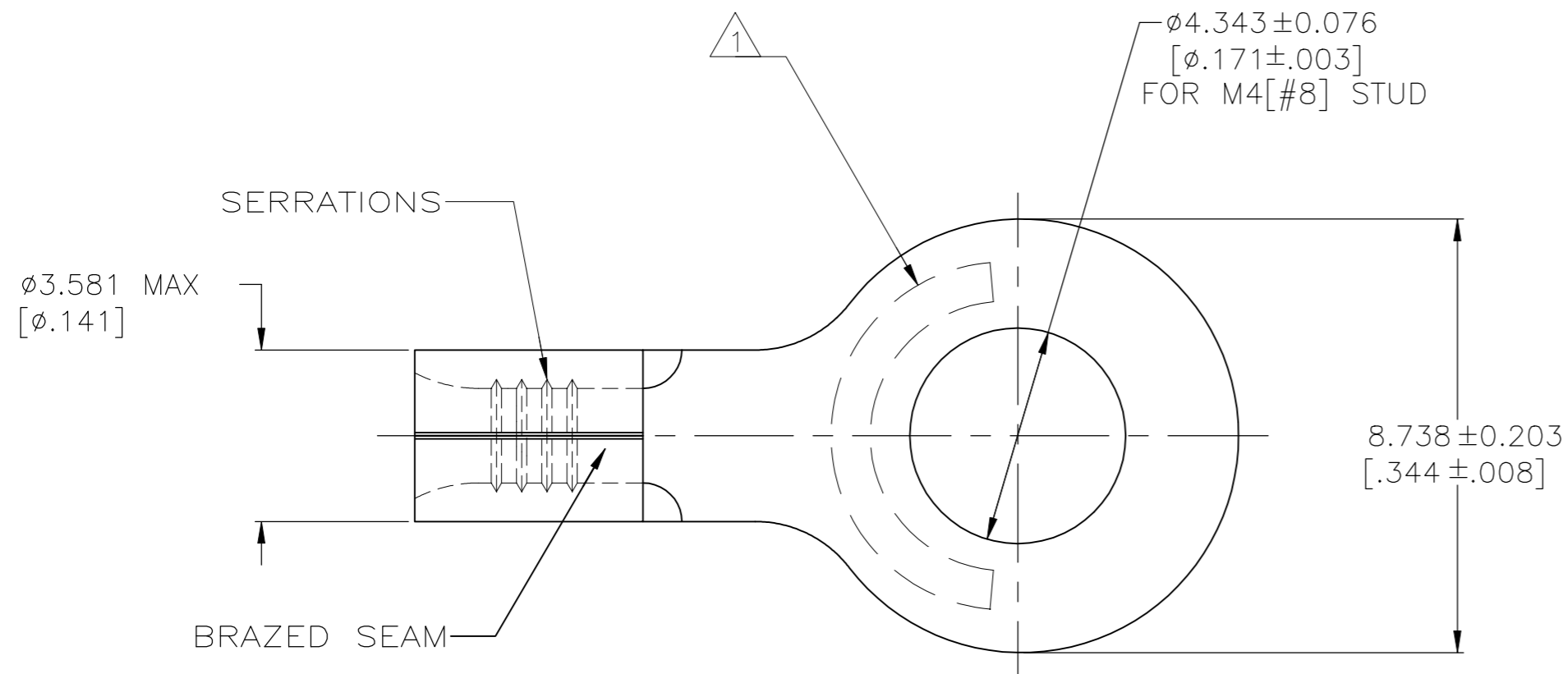

AMP WIRE RANGE	E13288 Listed
22-16 AWG SOLID OR STRANDED	22-16 AWG SOLID OR STRANDED
LR7189 Certified	MILITARY P/N AND CLASS
22-16 AWG SOLID OR STRANDED	NOT APPLICABLE

- 1 STAMP AMP 22-18* APPROX AS SHOWN
22-16 TERMINALS ARE STAMPED 22-18 IN
ACCORDANCE WITH MILITARY SPECIFICATION
SAE AS7928 COMMERCIAL WIRE RANGE IS 22-16
- 2 NOT UL/CSA APPROVED

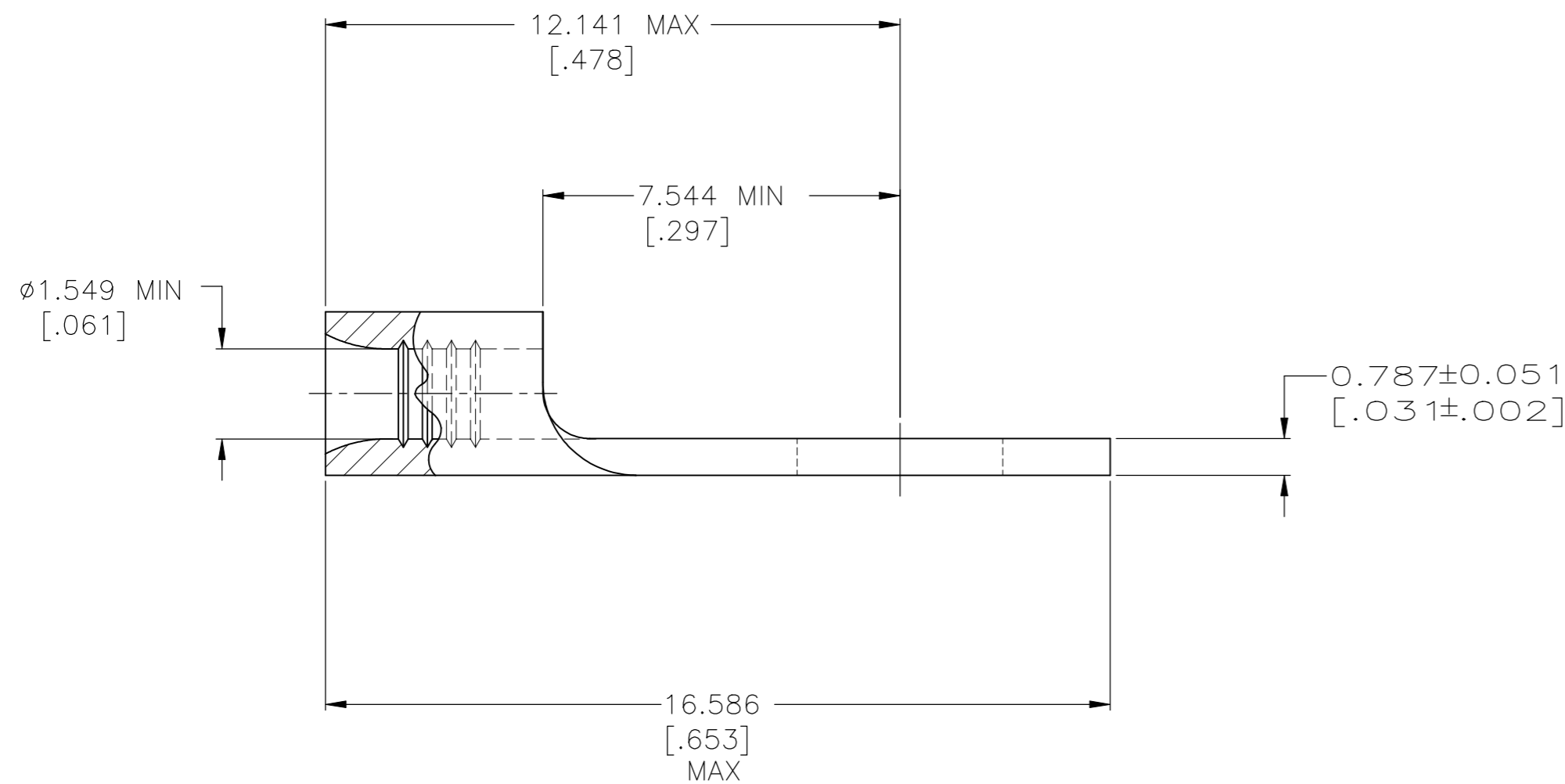

2 PRELIMINARY	5000	TAPE & REEL	323086-1
	1000	LOOSE PIECE	323086
	QTY	PACKAGING TYPE	PART NO

AMP INCORPORATED CUSTOMER SERVICE SYSTEMS			THIS DRAWING IS A CONTROLLED DOCUMENT.		DWN TA BRINKMAN 3-10-93	TE Connectivity Ltd.			
FOR ADDITIONAL PRODUCT INFORMATION OR COPIES OF DRAWINGS AND TECHNICAL DOCUMENTS	PRODUCT INFORMATION CENTER 1-800-522-6752	MAX RECOMMENDED OPERATING TEMPERATURE: 170°C [338°F] MAX	DIMENSIONS: mm [INCHES]	TOLERANCES UNLESS OTHERWISE SPECIFIED:	CHK DA PATTERSON 3-10-93				NAME
FOR APPLICATION TOOLING INFORMATION	TOOLING ASSISTANCE CENTER 1-800-722-1111	VOLTAGE RATING: -		0 PLC ± - 1 PLC ± - 2 PLC ± - 3 PLC ± 0.127[.005] 4 PLC ± - ANGLES ± -	APVD DE MILLER 3-10-93	UL 486 A-B			
FOR ORDER ENTRY	1-800-526-5142	WIRE CROSS SECTIONAL AREA RANGE, 0.26-1.65mm ² [509-3,260] CIR MILS SOLID OR STRANDED	MATERIAL COPPER PER ASTM B-152 ANNEALED	FINISH TIN PLATE 0.00254[.000100] MIN THK PER ASTM B545	PRODUCT SPEC APPLICATION SPEC	SIZE A2	CAGE CODE 00779	DRAWING NO C=323086	RESTRICTED TO -
CUSTOMER DRAWING					WEIGHT -	SCALE 8:1	SHEET 1 of 1	REV E1	