





A Product Line of
Diodes Incorporated



SPECIFICATION FOR APPROVAL

CUSTOMER	
NOMINAL FREQUENCY	12.000000 MHz
PRODUCT TYPE	TYPE F9 5x3.2 GLASS SEALED CRYSTAL
PART NUMBER	F91200088
CUSTOMER P/N	
ISSUE DATE	January 2, 2018
VERSION	C

APPROVED	PREPARED	QA
		

Diodes Incorporated

No.2, Ziqiang 5th Rd., Zhongli Industrial Park,
Zhongli Dist., Taoyuan City 32063, Taiwan (R.O.C.)
TEL:886-3-451-8888
FAX:886-3-461-3865
<https://www.diodes.com>

*RoHS Exemption

*HF-Halogen Free

*REACH Compliant

TYPE F9 5x3.2 GLASS SEALED CRYSTAL

F91200088

VER.C 02-JAN-18

VERSION HISTORY

Version No.	Version Date	Description	Notes
A	Feb. 10, 2012	Initial Release	
B	Nov. 1, 2012	Updated Mechanical Drawing	
C	Jan. 2, 2018	Updated logo	

TYPE F9 5x3.2 GLASS SEALED CRYSTAL

F91200088

VER.C 02-JAN-18

ELECTRICAL SPECIFICATIONS

Item	Symbol	Specifications	Units	Notes
Nominal Frequency	Fn	12.000000	MHz	
Mode of Oscillation	MO	AT Cut-Fundamental		
Calibration Load Capacitance	CL	12	pF	
Calibration Tolerance	FL	± 30	ppm	at 25°C $\pm 3^{\circ}\text{C}$
Operating Temperature Range	TR	-20 to +70	°C	
Frequency Stability(Frequency Deviation over the Operating Temperature Range)	F/T	± 50	ppm	Reference to the Frequency at 25°C
Operating Drive Level		10	μW	
Maximum Drive Level		100	μW	
Equivalent Series Resistance	ESR	70	Ω	Max.
Shunt Capacitance	C0	5	pF	Max.
Aging at 25°C		± 5	ppm	Max, 1st year
Storage Temperature		-55 to +125	°C	
Insulation Resistance		500	M Ω	Min

TYPE F9 5x3.2 GLASS SEALED CRYSTAL

F91200088

VER.C 02-JAN-18

RELIABILITY SPECIFICATIONS

MECHANICAL AND ENVIRONMENTAL RATINGS:

- a) FINE LEAK TEST: JESD22-A109 (Condition 1A)
- b) GROSS LEAK TEST: JESD22-A109 (Condition C)
- c) MOISTURE RESISTANCE: JESD22-A113
- d) SHOCK: JESD22-B104 (Condition B)
- e) SOLDERABILITY : (RoHS version): J-STD-002
- f) VIBRATION: JESD22-B103
- g) SOLVENT RESISTANCE: JESD22-B107
- h) RESISTANCE TO SOLDERING HEAT (RoHS version): J-STD-020D Table 5.2 Pb free devices (3 cycles max)

SUGGESTED IR REFLOW PROFILE

*As per IPC-JEDEC J-STD-020D



Note:

	Stage	Temperature	Time
A	Preheat	150~200°C	60~120 Sec
B	Primary Heat	217°C	60~150 Sec
C	Peak	260°C	10 Sec

TYPE F9 5x3.2 GLASS SEALED CRYSTAL

F91200088

VER.C 02-JAN-18

MARKING

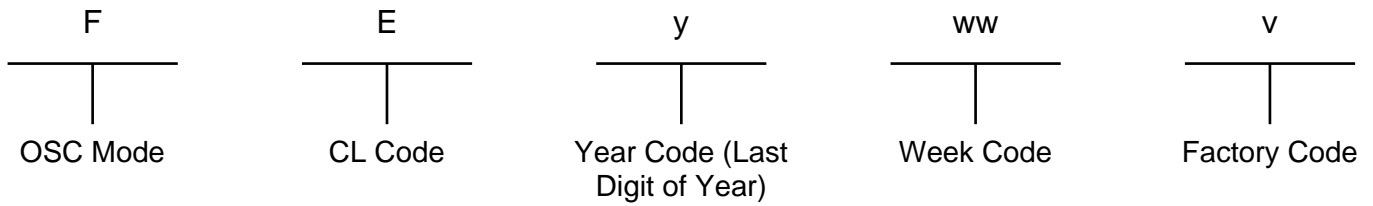
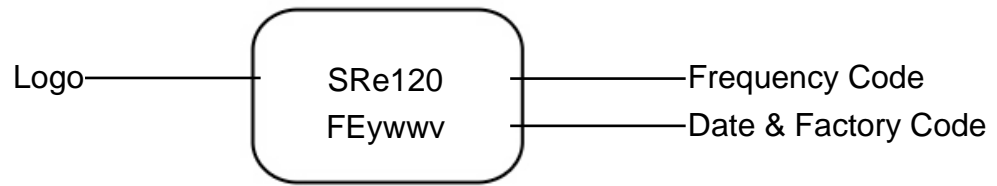

MECHANICAL DRAWINGS (Scale: None. Dimensions are in mm.)

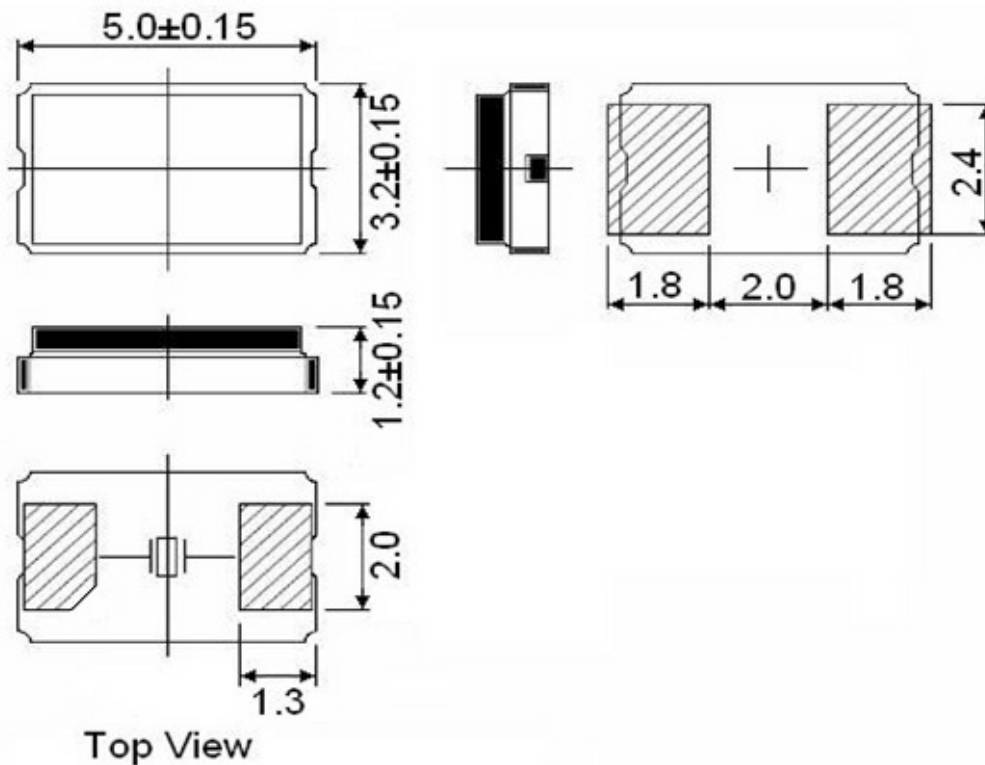

Note:

Pin shape is only for reference, and the Pin with chamfer or without chamfer is based on the real product.

TYPE F9 5x3.2 GLASS SEALED CRYSTAL

F91200088

VER.C 02-JAN-18

Tape & Reel

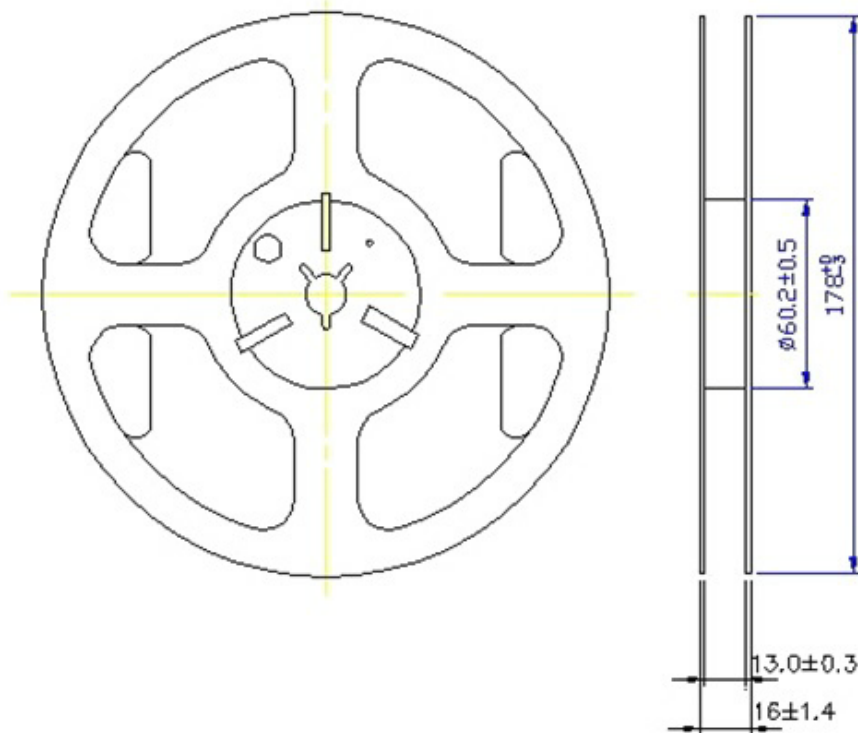
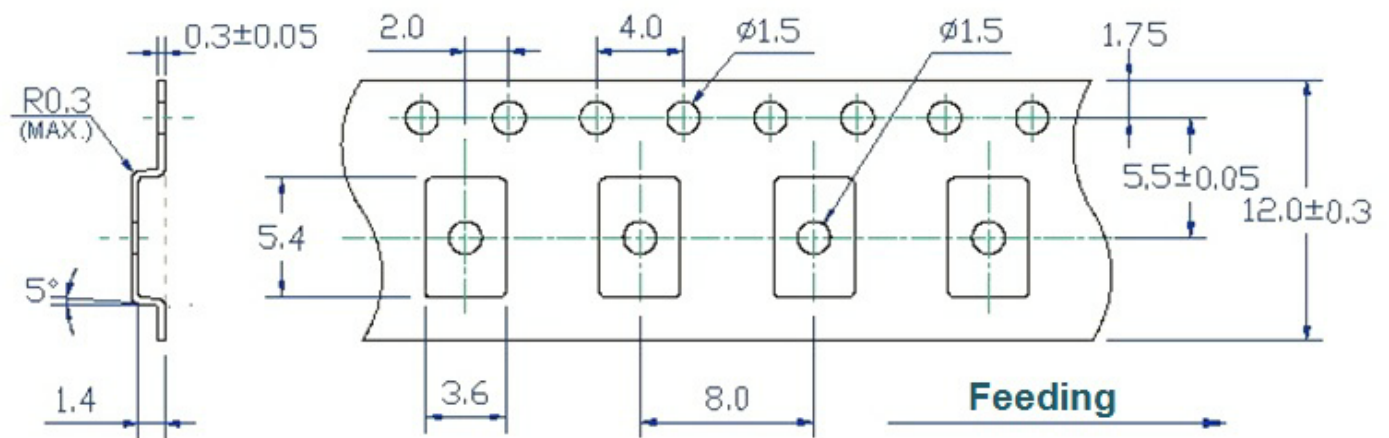

1. 230mm minimum leader which consist of carrier and/or tape followed by a minimum of 160mm of empty carrier tape sealed with cover tape.
2. 160mm minimum trailer of empty carrier tape sealed with cover tape.

TYPE F9 5x3.2 GLASS SEALED CRYSTAL

F91200088

VER.C 02-JAN-18

PACKING

