

## Evaluates: MAX16425/MAX16425A

## MAX16425/MAX16425A Evaluation Kit

### General Description

The MAX16425 evaluation kit (EV kit) serves as a reference platform for evaluating the MAX16425 voltage regulator IC and the MAX16425A EV kit evaluates the MAX16425A IC. The MAX16425/MAX16425A is a single-chip, integrated switching regulator that provides a compact, highly efficient, fast, accurate, and reliable power delivery solution for low-output voltage applications. The two devices have different programmability options to enable a wide range of configurations.

The EV kit consists of a fully assembled and tested Printed Circuit Board (PCB) implementation of the MAX16425/MAX16425A, Jumper pins, test points, and input/output connectors are included for flexibility and ease-of-use in a wide range of applications. Refer to the MAX16425 IC data sheet for more details.

[Ordering Information](#) appears at end of data sheet.

### MAX16425 EV Kit Board Photo

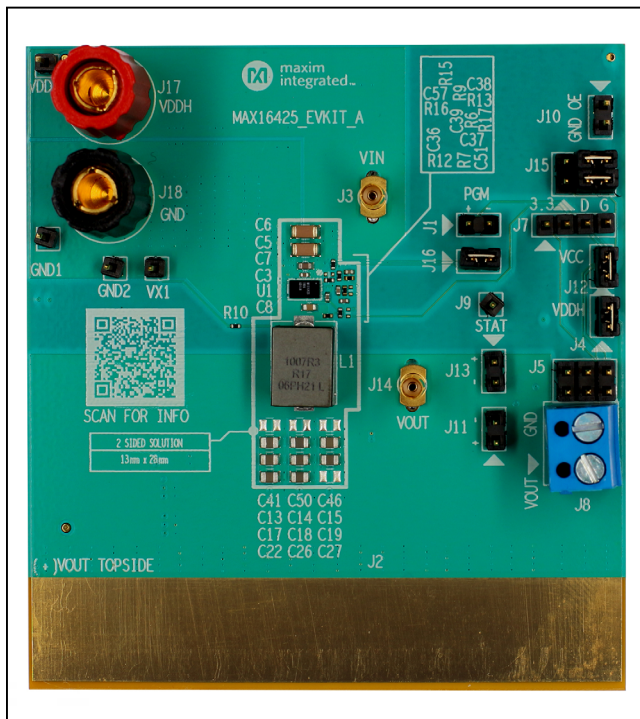

Quick-PWM is a trademark of Maxim Integrated Products, Inc.

### Benefits and Features

- 4.5V to 16V Input Voltage Range
- 0.6V to 3.3V Output Voltage Range
- 25A Maximum Load
- High-Efficiency Solution
  - Up to 97% Peak
  - Up to 87% Full Load
  - Up to 96% Light-Load Efficiency at 1A with DCM Enabled
- Flexible Design allows Early PCB Definition
  - Footprint Compatible with VT2491 (15A) and Related Scalable Products
  - Programmable Switching Frequency up to 1MHz
  - Programmable Soft-Start and STAT Delay Timings
  - Programmable Reference Voltage with External Input Option
  - Programmable Positive and Negative OCP Limit
- Advanced Architecture, Protection, and Reporting Guarantees Reliable Designs
  - Analog Current or Temperature Reporting
  - Differential Remote Sense with Open-Circuit Detection
  - Fast Transient Response with Quick-PWM™ Architecture
  - Percentage-Based Output Power Good and OVP
  - Open-Drain Status Indicator (STAT) Pin
  - Input Undervoltage and Overvoltage Lockout
  - Adaptive Dead-Time Control
- Saves Board Space
  - Integrated Boost Switch
  - 27-Bump WLCSP (2.2mm x 3.8mm) Footprint
  - Operation Using Ceramic Input and Output Capacitors

# MAX16425/MAX16425A Evaluation Kit

Evaluates: MAX16425/MAX16425A

## Quick Start

### Required Equipment

- MAX16425EVKIT#/MAX16425AEVKIT# EV kit
- 4.5V to 16V power supply
- Load capable of sinking 25A
- Oscilloscope, probes, and voltmeter

### Procedure

The EV kit is fully assembled and tested. Follow the steps below to verify board operation.

**Caution: Do not turn on the power supply until all connections are completed.**

- 1) Connect a 12V power supply to the banana jacks. Use red for positive and black for ground.
- 2) Make sure the shunt is installed on:
  - a) J16 (1-2) to close the sense line.
  - b) J4 (1-2) to power up the on-board LDO which regulates 1.8V.
  - c) J12 (1-2) to provide the 1.8V bias supply to the regulator from the on-board LDO.
  - d) J15 (3-5) to pull up the STAT pin.
  - e) J15 (4-6) to pull up the OE pin.
- 3) Connect a voltmeter to J8 (J11, J13, and J14 can be used as well)
- 4) Turn on the power supply.
- 5) Verify that the voltmeter reads 1V.

## Detailed Description of Hardware

The MAX16425/MAX16425A provides a compact, high-efficiency power delivery for precision outputs that demand fast transient response. The 27-bump (2.2mm x 3.8mm) CSP package minimizes the printed circuit board area. The EV kit is preset to a 1V output and can provide up to 25A from a 4.5V to 16V input supply.

### Bias Supply

The MAX16425/MAX16425A EV Kit has an on-board LDO (U2) which can provide the required 1.8V  $V_{CC}$  bias voltage to the regulator as well as the pull-up voltage for the Output Enable (OE) input. This allows testing the part using a single external power supply.

To enable the on-board LDO to install the shunt on jumper J4. To effectively use the LDO to supply the  $V_{CC}$  bias voltage to the regulator also install the shunt on jumper J12.

To measure the efficiency of the regulator accurately, the LDO should not be active. To disable it, both the shunts on J4 and J12 need to be removed. An external 1.8V, 0.1A current limited power supply needs to be connected between J12-2 and the ground. The same signal should be connected to J10 (1-2) to pull up the OE pin.

### Regulator Enable

To enable the regulator, the OE pin needs to be pulled HIGH. If the on-board 1.8V LDO is active (the shunt on jumper J4 is in place) its output voltage can be used for the purpose. Installing a shunt on J15 (4-6) pulls the OE signal HIGH to 1.8V through a 20k $\Omega$  resistor. To shut down the regulator a shunt needs to be installed on J10. This forces the OE pin LOW.

### Status Pin

The MAX16425/MAX16425A has an open collector status (STAT) output to report faults or output undervoltage events. Install a shunt on J15 (3- 5) to pull up this pin to  $V_{CC}$  through a 20k $\Omega$  resistor. Since STAT pin is 3.3V tolerant, a shunt on J15 (2-3) can be installed to pull up this pin through a 20k $\Omega$  resistor to the 3.3V provided by the on-board regulator U3 (install a shunt on J5 (3-4) to enable the LDO).

### Scenario Selection

Several parameters of the MAX16425/MAX16425A can be programmed to allow optimization for specific applications. By selecting the appropriate value of resistor  $R_{SEL}$  (R1) and capacitor  $C_{SEL}$  (C4), the optimum set of parameters (configuration) can be programmed. While  $R_{SEL}$  selects the proper scenario,  $C_{SEL}$  determines the nominal  $f_{SW}$ . [Table 1a](#) and [Table 1b](#) show the configuration tables for the MAX16425 and the MAX16425A, respectively.

A combination of  $R_{SEL}$  and  $C_{SEL}$  selects the  $f_{SW}$  setting. There are six options available (from #1 to #6), indicating six different nominal switching frequencies, from lowest to highest. Since the actual value of  $f_{SW}$  also depends on  $V_{OUT}$ , See [Figure 1](#) to select the proper  $f_{SW}$  setting for a specific application. By default, these EV kits are configured to have a switching frequency of 780kHz ( $f_{SW}$  #6 at  $V_{OUT} = 1V$ ).

The configuration tables for these two devices vary with respect to configurations for  $V_{REF}$ , valley OCP inception current, operation modes, current/temperature, reporting, and  $R_{SENSE}$  gain.

**Table 1a. MAX16425 Configuration Table**

R_SEL (kΩ)	V_REF (V)	SOFT- START TIME (t <sub>SS</sub> ) (ms)	VALLEY OCP INCEPTION (A)	OPERATION MODES	REPORTING (CURRENT / TEMP)	R <sub>SENSE</sub> (GAIN) (mΩ)	f <sub>SW</sub> SETTING			t <sub>STAT</sub> (μs)						
							C_SEL									
							0pF	200pF	820pF							
1.78	0.95	6	16	CCM	Current	2.8	f <sub>sw</sub> #4	f <sub>sw</sub> #5	f <sub>sw</sub> #6	2000						
2.67				CCM/DCM												
4.02				CCM												
6.04				CCM/DCM												
9.09	Ext.	3	CCM													
13.3			CCM													
20	0.6	6	24	CCM/DCM							Temp	1.4	f <sub>sw</sub> #1	f <sub>sw</sub> #2	f <sub>sw</sub> #3	128
30.9				CCM												
46.4			16	CCM/DCM							Current					
71.5				CCM/DCM												
107				CCM/DCM												
162	Ext.	1.5	20	CCM	Temp	1.4	f <sub>sw</sub> #1	f <sub>sw</sub> #2	f <sub>sw</sub> #3	128						

**Table 1b. MAX16425A Configuration Table**

R_SEL (kΩ)	V_REF (V)	SOFT- START TIME (t <sub>SS</sub> ) (ms)	VALLEY OCP INCEPTION (A)	OPERATION MODES	REPORTING (CURRENT/ TEMP)	R <sub>SENSE</sub> (GAIN) (mΩ)	f <sub>SW</sub> SETTING			t <sub>STAT</sub> (μs)	
							C_SEL				
							0pF	200pF	820pF		
1.78	0.95	1.5	16	CCM	Current	2.8	f <sub>sw</sub> #4	f <sub>sw</sub> #5	f <sub>sw</sub> #6	2000	
2.67				CCM/DCM							
4.02				CCM							
6.04				CCM/DCM							
9.09	Ext.	3	CCM	5.4							
13.3			CCM/DCM								
20	0.6	6	24	CCM/DCM							2.8
30.9				CCM							
46.4			16	CCM/DCM							5.4
71.5				CCM/DCM							
107				CCM/DCM							
162	Ext.	1.5	20	CCM	Temp	1.4	f <sub>sw</sub> #1	f <sub>sw</sub> #2	f <sub>sw</sub> #3	128	

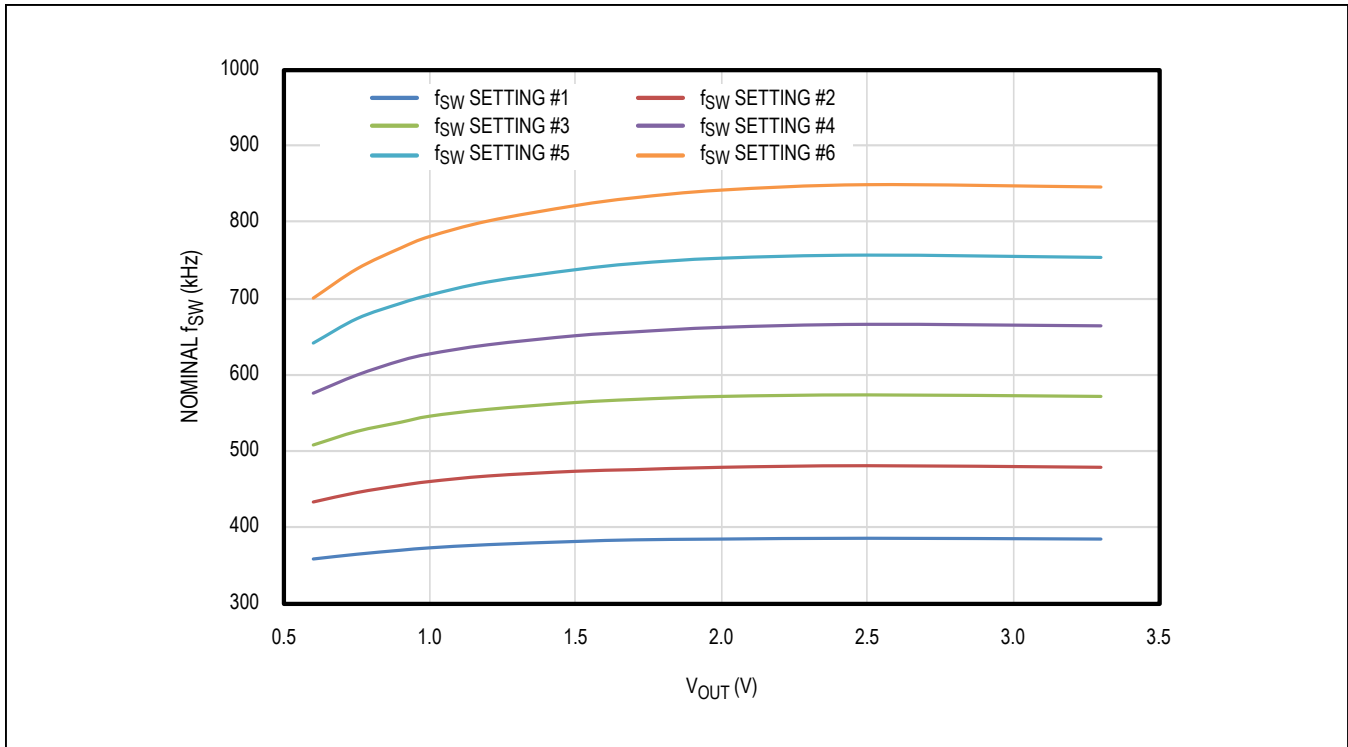

Figure 1. Nominal Switching Frequency vs. V<sub>OUT</sub> and f<sub>SW</sub> Setting

### Setting the Output Voltage

The output voltage of the MAX16425/MAX16425A is set by selecting a reference voltage and using an appropriate resistive voltage-divider, as shown in Equation 1.

**Equation 1:**

$$V_{OUT} = V_{REF} \times \left( 1 + \frac{R_{FB1}}{R_{FB2}} \right)$$

The reference voltage is selected using R\_SEL (see [Table 1a](#)) and can be either internal or external (Refer to the MAX16425 IC datasheet for more details). To improve the DC output-voltage accuracy, use the highest V<sub>REF</sub> value available and suitable for the application. For instance, use V<sub>REF</sub> = 0.6V for 0.6V ≤ V<sub>OUT</sub> < 0.95V and V<sub>REF</sub> = 0.95V for 0.95V ≤ V<sub>OUT</sub> < 5.5V.

To optimize the common-mode rejection of the error amplifier, choose the resistive voltage-dividers so that

their parallel resistance is as close as possible to 2kΩ (Equation 2).

**Equation 2:**

$$R_{FB1} = V_{OUT} \times \left( \frac{R_{PAR}}{R_{FB2}} \right)$$

$$R_{FB2} = R_{FB1} \times \left( \frac{R_{PAR}}{R_{FB1} - R_{PAR}} \right)$$

where:

R<sub>FB1</sub> = Top divider resistor

R<sub>FB2</sub> = Bottom divider resistor

R<sub>PAR</sub> = Desired parallel resistance of R<sub>FB1</sub> and R<sub>FB2</sub>

V<sub>OUT</sub> = Output voltage

V<sub>REF</sub> = Reference voltage

**Operation with External VREF**

When using an external reference, adopt the configuration as shown in Figure 2. The MAX16425/MAX16425A employ a specialized soft-start sequence. Once OE is asserted, the regulator briefly discharges the SENSE-node and releases it as regulation begins. The resulting soft-start ramp timing is determined by the external low-pass filter time constant. The external filter time constant needs to be lower than  $t_{SS}/3$  to avoid premature assertion of STAT pin while the output voltage is still ramping.

The external reference voltage should be limited between 0.8V and 1.1V and can be applied before enabling the regulator or ramped up right after enable is asserted. In both cases, the low-pass filtered reference voltage at SENSE- pin must reach its final value within  $t_{SS}$ .

Typical values for the filter components are:

- $R_F = 2.2k\Omega$
- $C_F = 0.22\mu F$

When changing the external reference voltage during normal operation (after the part has powered up, and reached regulation level), the regulator must be able to follow the reference-voltage change fast enough to avoid OVP and PWRGD faults. Please make sure that reference-voltage change timing from the initial to the final value does not exceed  $1/(2 \times BW)$ , where BW is the bandwidth of the regulator in Hertz (Hz).

**Status Monitoring**

The regulator status (STAT) signal provides an open-drain output (4V ABS MAX) that indicates whether the MAX16425/MAX16425A is functioning properly. J9 can be used to monitor the STAT signal.

Whenever the part is actively regulating, and the output voltage is within the Power Good (PWRGD) window, the STAT pin is HIGH. In all other conditions, including enabled but in a fault state, the STAT pin is pulled LOW. Refer to the MAX16425/MAX16425A IC data sheet for more details.

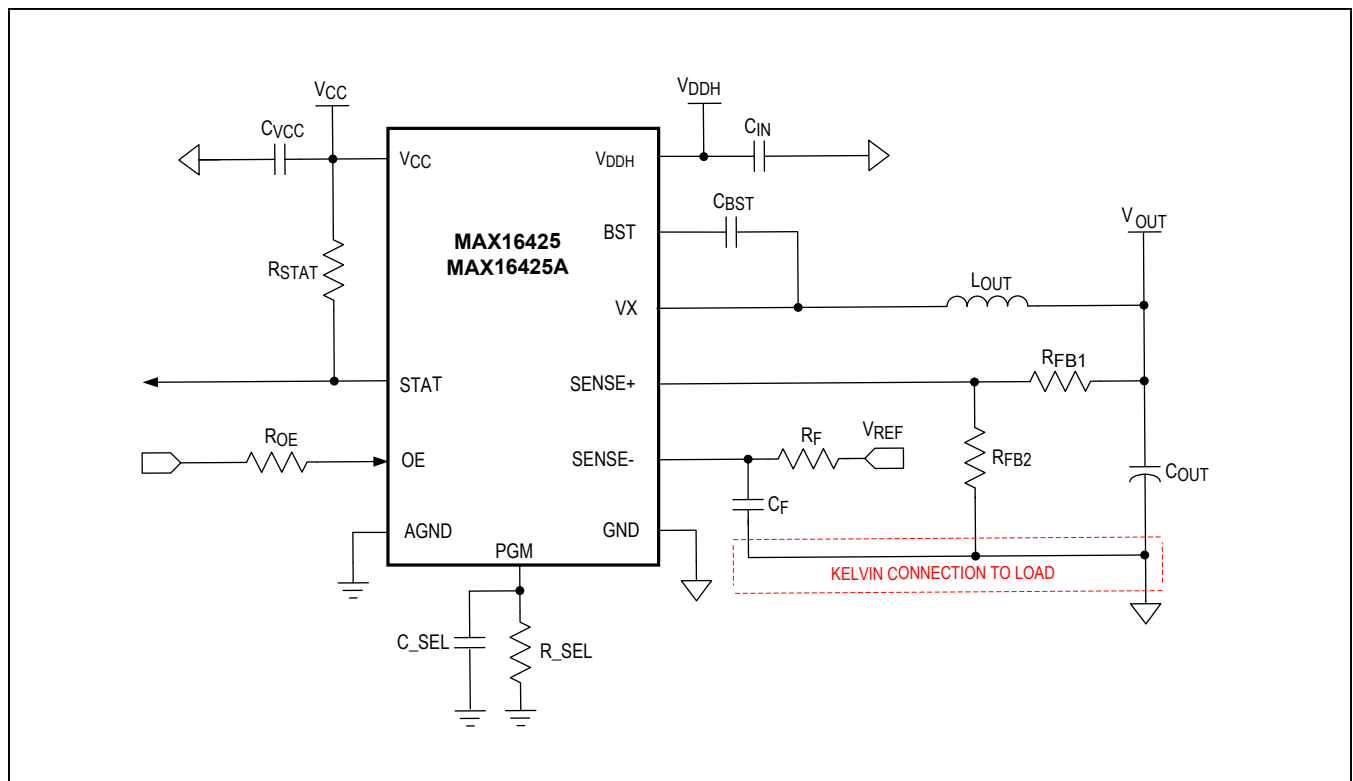

Figure 2. Electrical Connections to Use the External Voltage Reference Feature

## MAX16425/MAX16425A Evaluation Kit

Evaluates: MAX16425/MAX16425A

### Input Voltage Monitoring

V<sub>DD1</sub> and GND1 sense points as well as J3 can be used to monitor the input supply.

### Output Voltage Monitoring

J11 and J13 monitor the output voltage. These test points should not be used for loading. Use scopejack J14 to monitor the output voltage ripple on an oscilloscope.

### Efficiency Measurement

The following steps describe how to measure the regulator efficiency:

- 1) Connect a 12V power supply to the banana jacks. Use red for positive and black for ground. To avoid the input voltage to drop at high load due to power losses on connection cables connect the sense lines of the power supply to V<sub>DD1</sub> and GND1 headers.
- 2) Connect an external 1.8V, 0.1A current limited power supply between J12-2 and ground.
- 3) Connect the same power supply to J10-1 to enable the regulator.
- 4) Connect a load to the edge strip for better results. J8 can also be used for low currents.
- 5) Make sure the shunt is installed on J16 (1-2) to close the sense line.
- 6) Remove all the other jumpers.
- 7) Connect a voltmeter to J11 or J13.
- 8) Turn on the power supply.
- 9) Measure V<sub>IN</sub>, I<sub>IN</sub>, V<sub>OUT</sub>, I<sub>OUT</sub>, V<sub>BIAS</sub> and I<sub>BIAS</sub>.
- 10) Calculate the efficiency using Equation 3.

#### Equation 3:

$$\eta = V_{OUT} \times \frac{I_{OUT}}{(V_{IN} + I_{IN}) + (V_{BIAS} \times I_{BIAS})}$$

### Ordering Information

PART	TYPE
MAX16425EVKIT#	EV Kit
MAX16425AEVKIT#	EV Kit

#Denotes RoHS compliance

# MAX16425/MAX16425A Evaluation Kit

Evaluates: MAX16425/MAX16425A

## MAX16425/MAX16425A EV Kit Bill of Materials

ITEM	REF_ DES	DNI/ DNP	QTY	MFG PART #	MANUFACTURER	VALUE	DESCRIPTION
1	C1, C2	-	2	TPSD107K020R0085	AVX	100UF	CAP; SMT (7343); 100UF; 10%; 20V; TANTALUM
2	C3	-	1	GRM155R71E104KE14; C1005X7R1E104K050BB; TMK105B7104KVH; CGJ2B3X7R1E104K050BB	MURATA;TDK; TAIYO YUDEN; TDK	0.1UF	CAP; SMT (0402); 0.1UF; 10%; 25V; X7R; CERAMIC
3	C4	-	1	C0402C821K5RAC; GRM155R71H821KA01	KEMET;MURATA	820PF	CAP; SMT (0402); 820PF; 10%; 50V; X7R; CERAMIC
4	C5, C6, C10, C11	-	4	GRM31CR71E106KA12; CL31B106KAHNNN; C3216X7R1E106K160AB	MURATA; SAMSUNG; TDK	10UF	CAP; SMT (1206); 10UF; 10%; 25V; X7R; CERAMIC
5	C7, C21, C54	-	3	TMK107B7105KA; 06033C105KAT2A; C1608X7R1E105K080AE	MURATA; TAIYO YUDEN; AVX;TAIYO YUDEN	1UF	CAP; SMT (0603); 1UF; 10%; 25V; X7R; CERAMIC
6	C8	-	1	GRM188R71E474KA12	MURATA	0.47UF	CAP; SMT (0603); 0.47UF; 10%; 25V; X7R; CERAMIC
7	C9, C55	-	2	GRM155R60J475ME87; GRM153R60J475ME15; GRM155R60J475ME47	MURATA; MURATA; MURATA	4.7UF	CAP; SMT (0402); 4.7UF; 20%; 6.3V; X5R; CERAMIC
8	C12-C20, C22, C26, C33	-	12	CL21A476MQYNNN; C2012X5R0J476M125AC; JMK212BJ476MG	SAMSUNG ELECTRONICS; TDK; TAIYO YUDEN	47UF	CAP; SMT (0805); 47UF; 20%; 6.3V; X5R; CERAMIC
9	C24	-	1	C0402C103K5RAC; GRM155R71H103KA88; C1005X7R1H103K050BE; CL05B103KB5NNN; UMK105B7103KV	KEMET;MURATA; TDK;SAMSUNG ELECTRONIC; TAIYO YUDEN	0.01UF	CAP; SMT (0402); 0.01UF; 10%; 50V; X7R; CERAMIC
10	C36	-	1	C0402C105K8PAC; CC0402KRX5R6BB105	KEMET; YAGEO	1UF	CAP; SMT (0402); 1UF; 10%; 10V; X5R; CERAMIC
11	C37	-	1	TMK105BJ682KVH	TAIYO YUDEN	6800PF	CAP; SMT (0402); 6800PF; 10%; 25V; X5R; CERAMIC
12	C38	-	1	C0402C153K4RAC; GRM155R71C153KA01	KEMET; MURATA	0.015UF	CAP; SMT (0402); 0.015UF; 10%; 16V; X7R; CERAMIC
13	C39	-	1	CGA2B2X7R1H222K050BA; GCM155R71H222KA37	TDK; MURATA	2200PF	CAP; SMT (0402); 2200PF; 10%; 50V; X7R; CERAMIC
14	D1	-	1	MBRS540T3G	ON SEMICONDUCTOR	MBRS540T3	DIODE; SCH; SURFACE MOUNT SCHOTTKY POWER RECTIFIER; SMC; PIV=40V; IF=5A
15	GND1, GND2, J9, VDD1, VX1	-	5	TSW-101-07-L-S	SAMTEC	TSW-101-07-L-S	CONNECTOR; MALE; THROUGH HOLE; TSW SERIES; STRAIGHT; 1PIN



# MAX16425/MAX16425A Evaluation Kit

Evaluates: MAX16425/MAX16425A

## MAX16425/MAX16425A EV Kit Bill of Materials (continued)

ITEM	REF_DES	DNI/DNP	QTY	MFG PART #	MANUFACTURER	VALUE	DESCRIPTION
16	J1, J4, J10-J13, J16	-	7	TSW-101-07-L-D	SAMTEC	TSW-101-07-L-D	CONNECTOR; MALE; THROUGH HOLE; TSW SERIES; DOUBLE ROW; STRAIGHT; 2PINS
17	J3, J14	-	2	129-0701-202	JOHNSON COMPONENTS	129-0701-202	CONNECTOR; FEMALE; THROUGH HOLE; SHIELDED TEST VERTICAL JACK ; STRAIGHT; 3PINS
18	J5, J15	-	2	TSW-103-07-L-D	SAMTEC	TSW-103-07-L-D	CONNECTOR; MALE; THROUGH HOLE; THROUGH HOLE 0.025 POST HEADER; STRAIGHT; 6PINS
19	J7	-	1	TSW-104-07-L-S	SAMTEC	TSW-104-07-L-S	CONNECTOR; MALE; THROUGH HOLE; TSW SERIES; SINGLE ROW; STRAIGHT; 4PINS
20	J8	-	1	ED120/2DS	ON-SHORE TECHNOLOGY INC.	ED120/2DS	CONNECTOR; FEMALE; THROUGH HOLE; BLUE TERMINAL BLOCK; STRAIGHT; 2PINS
21	J17	-	1	3750-2	POMONA ELECTRONICS	3750-2	CONNECTOR; FEMALE; SMT; COLOR RED; STANDARD BINDING POST; STRAIGHT; 1PIN
22	J18	-	1	3750-0	POMONA ELECTRONICS	3750-0	CONNECTOR; FEMALE; SMT; COLOR BLACK; STANDARD BINDING POST; STRAIGHT; 1PIN
23	L1	-	1	FP1007R3-R17-R	COOPER BUSSMANN	170NH	INDUCTOR; SMT; FERRITE CORE; 170NH; TOL=+/-10%; 61A
24	R1	-	1	CRCW040230K9FK	VISHAY DALE	30.9K	RES; SMT (0402); 30.9K; 1%; +/-100PPM/DEGC; 0.0630W
25	R2, R3	-	2	ERJ-2RKF1002	PANASONIC	10K	RES; SMT (0402); 10K; 1%; +/-100PPM/DEGC; 0.1000W
26	R4, R7, R11, R15, R16	-	5	ERJ-2GE0R00	PANASONIC	0	RES; SMT (0402); 0; JUMPER; JUMPER; 0.1000W
27	R5, R8	-	2	ERJ-2GEJ203	PANASONIC	20K	RES; SMT (0402); 20K; 5%; +/-200PPM/DEGC; 0.1000W
28	R6, R13	-	2	CRCW04022K10FK	VISHAY DALE	2.1K	RES; SMT (0402); 2.1K; 1%; +/-100PPM/DEGC; 0.0630W
29	R9	-	1	ERJ-2RKF2801	PANASONIC	2.8K	RES; SMT (0402); 2.8K; 1%; +/-100PPM/DEGC; 0.1000W



# MAX16425/MAX16425A Evaluation Kit

Evaluates: MAX16425/MAX16425A

## MAX16425/MAX16425A EV Kit Bill of Materials (continued)

ITEM	REF_DES	DNI/DNP	QTY	MFG PART #	MANUFACTURER	VALUE	DESCRIPTION
30	R10	-	1	ERJ-2GEJ102	PANASONIC	1K	RES; SMT (0402); 1K; 5%; +/-200PPM/DEGC; 0.1000W
31	R12	-	1	CRCW040220K0FK	VISHAY DALE	20K	RES; SMT (0402); 20K; 1%; +/-100PPM/DEGC; 0.0630W
32	R14	-	1	ERJ-2RKF2000	PANASONIC	200	RES; SMT (0402); 200; 1%; +/-100PPM/DEGC; 0.1000W
33	SU1-SU5	-	5	S1100-B;SX1100-B; STC02SYAN	KYCON; KYCON; SULLINS ELECTRONICS CORP.	SX1100-B	TEST POINT; JUMPER; STR; TOTAL LENGTH=0.24IN; BLACK; INSULATION=PBT;PHOSPHOR BRONZE CONTACT=GOLD PLATED
34	U1	-	1	MAX16425GCJ+/ MAX16425AGCJ+	ANALOG DEVICES	MAX16425GCJ+/ MAX16425AGCJ+	IC; VREG; INTEGRATED; STEP-DOWN SWITCHING REGULATOR; WLCSP27
35	U2	-	1	MIC5235-1.8YM5	MICROCHIP	MIC5235-1.8YM5	IC; VREG; ULTRA-LOW QUIESCENT CURRENT; 150MA MICROCAP LDO REGULATOR; SOT23-5
36	U3	-	1	MIC5235-3.3YM5	MICROCHIP	MIC5235-3.3YM5	IC; VREG; ULTRA-LOW QUIESCENT CURRENT; 150MA MICROCAP LDO REGULATOR; SOT23-5
37	PCB	-	1	MAX16425/MAX16425A	ANALOG DEVICES	PCB	PCB:MAX16425/ PCB:MAX16425A
38	C27, C30, C34, C40-C50, C52, C53	DNP	0	CL21A476MQYNNN; C2012X5R0J476M125AC; JMK212BJ476MG	SAMSUNG ELECTRONICS; TDK; TAIYO YUDEN	47UF	CAP; SMT (0805); 47UF; 20%; 6.3V; X5R; CERAMIC
39	C28, C29	DNP	0	T494D227M010AT	KEMET	220UF	CAP; SMT (7343); 220UF; 20%; 10V; TANTALUM ;NOTE:PURCHASE DIRECT FROM THE MANUFACTURER
40	C51	DNP	0	C0402C105K8PAC; CC0402KRX5R6BB105	KEMET; YAGEO	1UF	CAP; SMT (0402); 1UF; 10%; 10V; X5R; CERAMIC
41	C57	DNP	0	C0402X5R100-224KNP; GRM155R61A224KE19; 0402ZD224KAT2A	MURATA; VENKEL;AVX	0.22UF	CAP; SMT (0402); 0.22UF; 10%; 10V; X5R; CERAMIC
42	R17	DNP	0	ERJ-2RKF1001	PANASONIC	1K	RES; SMT (0402); 1K; 1%; +/-100PPM/DEGC; 0.1000W
<b>TOTAL</b>			<b>78</b>				

# MAX16425/MAX16425A Evaluation Kit

Evaluates: MAX16425/MAX16425A

## MAX16425/MAX16425A EV Kit Schematic Diagram

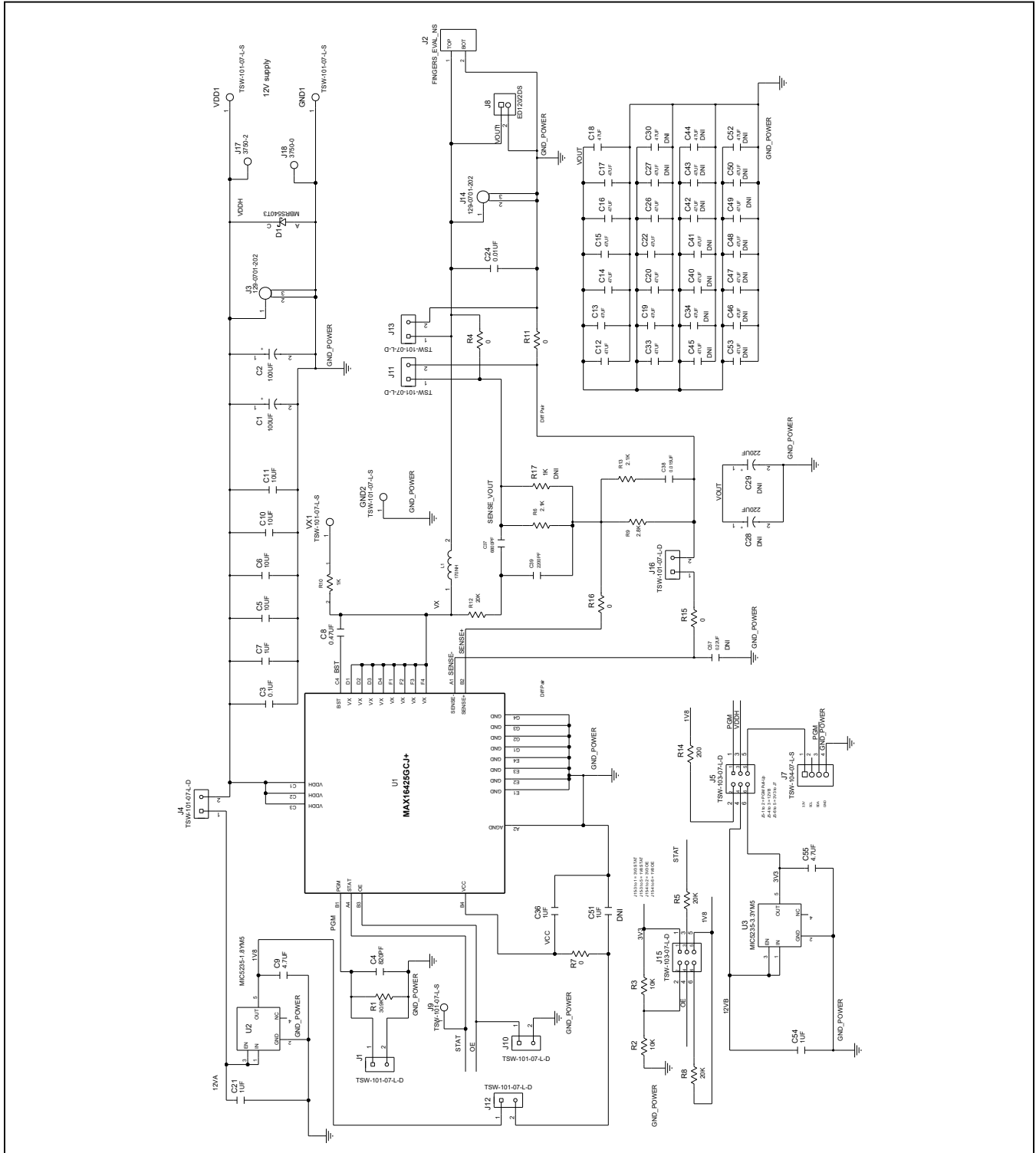

# MAX16425/MAX16425A Evaluation Kit

Evaluates: MAX16425/MAX16425A

## MAX16425/MAX16425A PCB Layout Diagrams

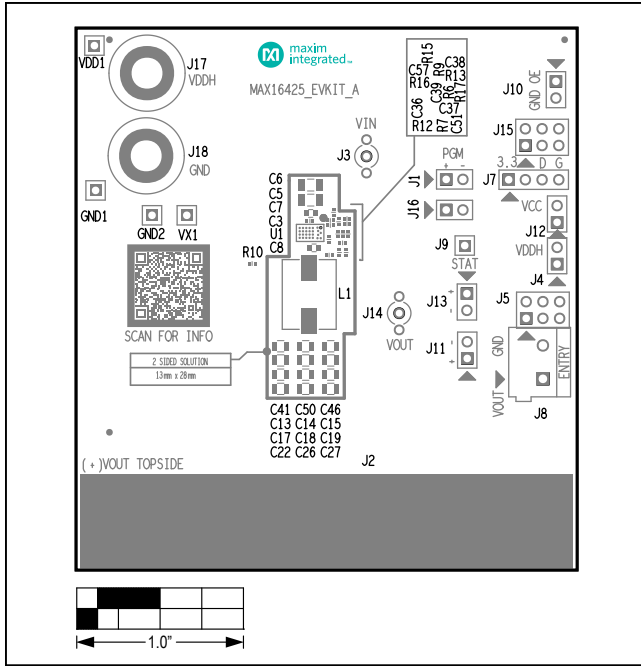

MAX16425/MAX16425A Component Placement Guide—Top Silkscreen

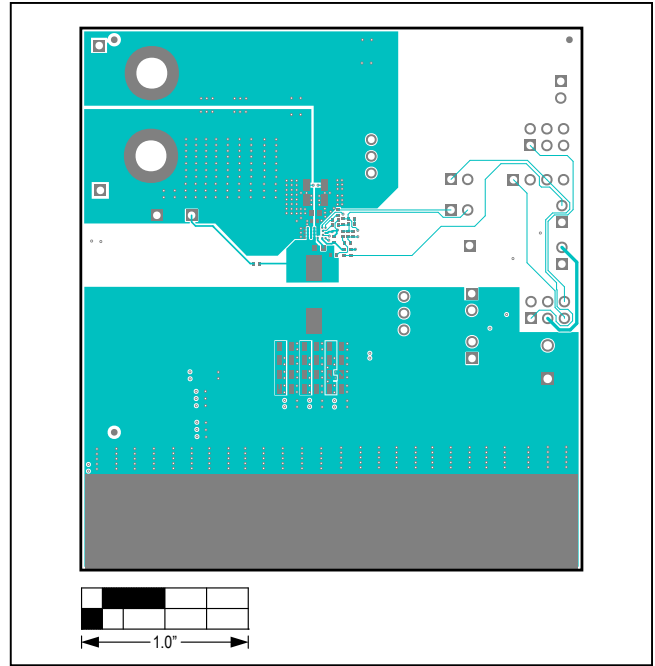

MAX16425/MAX16425A PCB Layout—Top View

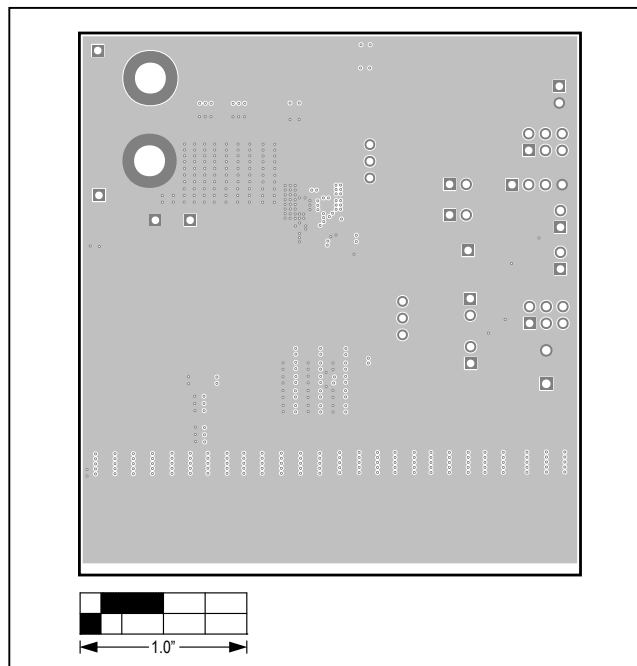

MAX16425/MAX16425A PCB Layout—Layer 2

# MAX16425/MAX16425A Evaluation Kit

Evaluates: MAX16425/MAX16425A

## MAX16425/MAX16425A PCB Layout Diagrams (continued)

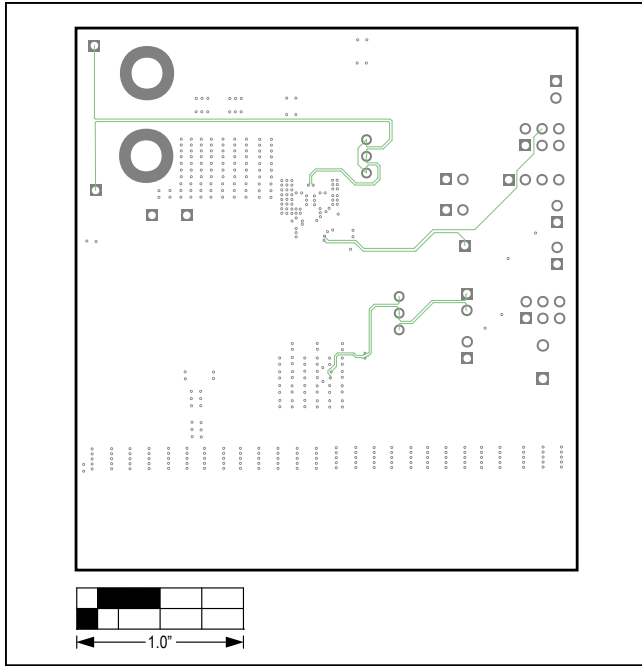

MAX16425/MAX16425A PCB Layout—Layer 3

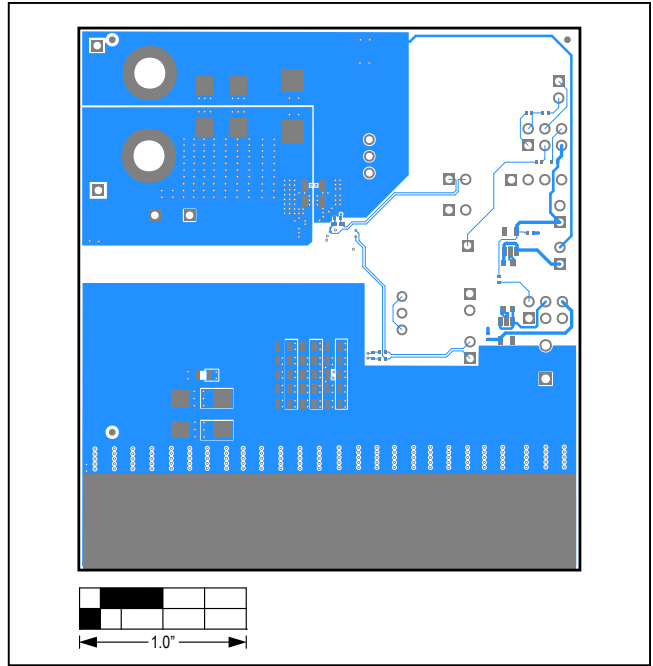

MAX16425/MAX16425A PCB Layout—Bottom View

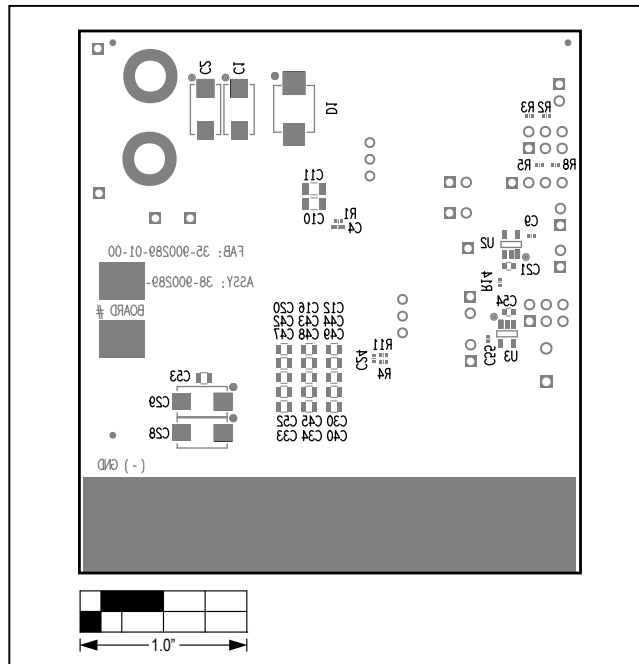

MAX16425/MAX16425A PCB Layout—Bottom Silkscreen

# MAX16425/MAX16425A Evaluation Kit

Evaluates: MAX16425/MAX16425A

## Revision History

REVISION NUMBER	REVISION DATE	DESCRIPTION	PAGES CHANGED
0	8/21	Release for Market Intro	—

