

PART NUMBER	REVISION	DESCRIPTION	FEED TYPE
2151961-1	D	FINE CRIMP HEIGHT ADJUST	MECHANICAL
2151961-2	D	FINE CRIMP HEIGHT ADJUST	PNEUMATIC
5-2151961-1	D	SEAL STRIPPER CRIMPER TERMINATING UNIT	MECHANICAL
5-2151961-2	D	SEAL STRIPPER CRIMPER TERMINATING UNIT	PNEUMATIC
7-2151961-1	D	MECHANICAL AND CRIMP TOOLING KIT	MECHANICAL
7-2151961-2	D	PNEUMATIC AND CRIMP TOOLING KIT	PNEUMATIC
7-2151961-7	A	CRIMP TOOLING KIT	-

ATLANTIC VERSION TERMINATOR INTERFACE ADAPTER



APPLICATOR DATA		
CRIMP	SIZE	TYPE
WIRE	1.45 mm [.057]	F
INSUL	2.19 mm [.086]	O

APPLICATOR INSTRUCTIONS 408-35042

TERMINAL DATA: SUMITOMO TERMINAL SUMITOMO CRIMP SPECIFICATION	
TERMINAL NAME: 0.64 SEALED FEMALE TERMINAL	
WIRE STRIP LENGTH 3.50-4.50 mm [.138-.177 IN]	TERMINAL INSULATION DIAMETER RANGE Ø1.20-1.90 mm [.047-.075 IN]
TERMINAL APPLICATION SPECIFICATION	SUMITOMO CONTROL NO. T-211E-H

TERMINALS APPLIED				SEAL INSULATION DIAMETER RANGE
TE TERMINAL	SUMITOMO TERMINAL	TE SEAL	SUMITOMO SEAL	
1949253-1	8100-3455	2113347-1	7165-1198	Ø1.4-1.5mm
1949253-2	8100-3456	1949254-1	7165-1199	Ø1.6-1.7mm
2303723-1	8100-3617	1949996-1	7165-0796	Ø1.2-2.0mm
		3311515-1	7165-1312	Ø1.1-1.4mm

WIRE SIZE	CRIMP HEIGHT mm [INCH]	CRIMP HEIGHT REFERENCE SETTING
0.50mm ²	1.10+/-0.05 [.043+/-0.002]	7.2
0.30mm ²	0.95+/-0.05 [.037+/-0.002]	9.2

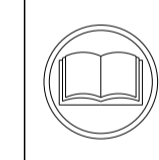

- 1 RECOMMENDED SPARE PARTS
- 2 REFER TO SUPPLIED INSTRUCTION SHEET FOR CLEANING, LUBRICATION AND STORAGE OF APPLICATOR.
- 3 APPLY PART NUMBER 2-23419-6 LOCTITE TO THREADS OF ITEMS 242. APPLY PART NUMBER 1-23419-5 LOCTITE TO THREADS OF ITEMS 180.
- 4 CRIMP HEIGHT REFERENCE SETTING WAS THE SETTING USED WHEN THE APPLICATOR WAS QUALIFIED AT THE FACTORY. ADJUSTMENT MAY BE NECESSARY WHEN RUNNING APPLICATOR IN THE FIELD.
- 5 APPLY TORO-SEAL IN ALLEN SOCKET TO FILL HOLE AFTER FLAT HD HAS BEEN ADJUSTED TO CORRECT HEIGHT AT QUALIFICATION. APPLY #1-23419-5 LOC-TITE TO THREADS.
- 6 UNLESS SPECIFIED OTHERWISE TORQUE VALUES SHALL BE USED PER DOCUMENT, 101-35000.
- 7 FOR 0.30mm² WIRE SIZE ONLY.
- 8 FOR 0.50mm² WIRE SIZE ONLY.
- 9 TERMINAL LUBRICANT IS RECOMMENDED.

***WARNING**
 ON INSTALLATION, SET WIRE DISC TO CRIMP HEIGHT REFERENCE SETTING FOR LARGEST WIRE SIZE. CRIMP HEIGHT REFERENCE SETTINGS GREATER THAN THE VALUE SHOWN MAY CAUSE DAMAGE TO THE CRIMP TOOLING, REFER TO THE INSTRUCTION SHEET FOR PROPER SETUP AND ADJUSTMENTS.

ATLANTIC VERSION
 Shown on sheets 1 of 4 & 2 of 4
 (Pacific version shown on sheets 3 of 4 & 4 of 4)

LOC	DIST	REVISIONS					
A	66	P	LTN	DESCRIPTION	DATE	OWN	APVD
		B		ECR-18-007180	11MAY2018	FZ	KZ
		B1		ECR-18-008724	05JUN2018	FZ	KZ
		C		ECR-19-010974	12JUL2019	FJ	TE
		D		ECR-19-011508	22JUL2019	TB	TE

-	-	-	1	1	-	-	1803515-3	RAM ASSEMBLY, SF ATLANTIC	293
-	-	-	1	1	-	-	2-1803583-1	APPLICATOR BASIC ASSEMBLY, SF	292
-	1	-	1	-	1	-	2119641-1	FEED CAM, AIR FEED	248
-	1	1	1	1	1	1	2119082-8	CAM, SNAIL, INSULATION ADJUSTMENT	244
-	1	1	1	1	1	1	2079764-1	WASHER, WAVE SPRING, CREST-TO-CREST	243
3	-	1	1	1	1	1	2119083-1	RETAINER, INSULATION DIAL	242
-	1	1	1	1	1	1	7-18023-7	SCR, SKT HD CAP M3 X 4.0	241
-	-	1	-	1	-	1	2119580-1	MECHANICAL FEED ASSEMBLY	239
-	1	-	1	-	1	-	2844940-1	AIR FEED MODULE	238
-	-	-	1	1	-	-	4-1722335-3	STRIPPER, SIDE FEED	182
-	-	-	1	1	-	-	1-5018030-0	NUT, HEX, REG, RoHS, M3.5	181
3	-	-	-	1	1	-	1-1752354-9	STANDOFF, HOLD-DOWN	180
-	-	-	1	1	-	-	993111-1	PIN, SLOTTED SPRING 3.0 X 20.0	177
-	-	-	1	1	-	-	5-22280-0	SPRING, COMPRESSION	176
-	-	-	1	1	-	-	1752353-3	GUIDE PIN, HOLDDOWN	175
-	-	-	1	1	-	-	1901680-2	GUIDE PIN, HOLDDOWN	174
-	REF	REF	REF	REF	REF	REF	994970-2	COUNTER, MAGNETIC	164
9	-	1	1	1	1	1	2119955-1	ASSY, LUBRICATOR, SIDE FEED	113
-	1	1	1	1	1	1	2844908-1	SCREW, LOCKING	99
-	1	1	1	1	1	1	2844907-1	POST, LOCKING	98
-	1	1	1	1	1	1	455888-7	SPACER, CRIMPER	82
-	1	1	1	1	1	1	1803607-3	DOCUMENTATION PACKAGE	71
-	1	1	1	1	1	1	2119740-1	TAG, IDENTIFICATION	67
-	2	2	2	2	2	2	2168078-1	SCREW, DRIVE, RH, RoHS, 2 x .188	66
-	1	1	1	1	1	1	2168083-2	SCR, SKT HD CAP, RoHS, M4 X 8.0	60
-	1	1	1	1	1	1	5-18022-5	SCR, HEX HD CAP, M4 X 6.0	59
5	-	1	1	1	1	1	985575-3	SCR, FLT SKT HD CAP M3 X 10.0	57
-	1	1	1	1	1	1	1338685-1	PAWL, FEED	56
-	4	4	4	4	4	4	2168083-3	SCR, SKT HD CAP, RoHS, M4 X 12.0	54
-	2	2	2	2	2	2	2168083-3	SCR, SKT HD CAP, RoHS, M4 X 12.0	53
-	1	1	1	1	1	1	5018030-1	NUT, HEX, REG, RoHS, M3	52
-	1	1	1	1	1	1	811242-5	BUMPER, HOLD DOWN	51
-	1	1	1	1	1	1	690753-2	SPACER, TONKER	50
-	1	2	1	2	1	2	18023-9	SCR, SKT HD CAP M4 X 6.0	49
-	-	1	-	1	-	1	2119652-1	FEED CAM, PRE FEED	48
-	-	1	-	1	-	1	2119653-1	FEED CAM, POST FEED	47
-	1	1	-	-	1	1	1803583-9	APPLICATOR BASIC ASSEMBLY, SF	46
-	1	1	-	-	1	1	1803515-1	RAM ASSEMBLY, SF ATLANTIC	44
-	1	1	1	1	1	1	1803602-1	SCR, BHSC, RoHS (M8 X 25)	41
-	1	1	1	1	1	1	1752356-6	SUPPORT, TERMINAL	34
-	2	2	2	2	2	2	2079383-5	SCR, BHSC, RoHS (M4 X 20)	33
-	2	2	2	2	2	2	2-2844962-8	SPACER, CYLINDRICAL, STRIP GUIDE	30
-	1	1	1	1	1	1	2844992-1	ASSEMBLY, STRIP GUIDE	29
-	1	1	1	1	1	1	1-455888-0	SPACER, CRIMPER	28
-	1	1	1	1	1	1	1320928-2	STRIP GUIDE	24
-	1	1	-	-	1	1	2168083-2	SCR, SKT HD CAP, RoHS, M4 X 8.0	21
-	2	2	1	1	2	2	1-18028-2	WASHER, FLAT, REG M4	20
-	1	1	-	-	1	1	2119533-1	STRIPPER, SIDE FEED	19
1	-	1	1	1	1	1	2119806-1	INSERT, SHEAR	13
-	1	1	1	1	1	1	3-22280-3	SPRING, COMPRESSION	12
-	1	1	1	1	1	1	1-356885-4	STOP, SHEAR	11
1	-	1	1	1	1	1	2119805-1	SHEAR HOLDER, FRONT	10
1	-	1	1	1	1	1	318707-1	FLOATING SHEAR, FRONT	9
1	1	2	2	1	1	1	5-1633927-1	ANVIL, COMBINATION	8
-	1	1	1	1	1	1	3-240641-4	SPACER	7
-	-	-	-	-	-	-	-	-	6
-	1	1	1	1	1	1	2119781-1	DEPRESSOR, SHEAR	5
-	1	1	1	1	1	1	4-238011-0	BLOCK, CRIMPER SPACER	4
1	1	2	2	1	1	1	2-1803018-5	CRIMPER, INSULATION O	3
-	1	1	1	1	1	1	455888-4	SPACER, CRIMPER	2
1	1	2	2	1	1	1	4-1633305-8	CRIMPER, WIRE PREMIUM	1

ITEM NO	PART NO	DESCRIPTION	ITEM NO
-77	-72	-71	-52
-51	-2	-1	

DATE: 05JUL2013	CHK: H. STAKEM	DATE: 05JUL2013	NAME: T. ELBIN
DATE: 05JUL2013	CHK: T. ELBIN	DATE: 05JUL2013	NAME: T. ELBIN
DATE: 05JUL2013	CHK: T. ELBIN	DATE: 05JUL2013	NAME: T. ELBIN

TE Connectivity	Harrisburg, PA 17105-3608
Ocean Side Feed	Applicator
SIZE: A1	CAGE CODE: 00779
DRAWING NO: 2151961	SCALE: 1:2
SHEET: 1	OF: 4
REV: D	

LOC	DIST	REVISIONS					
		P	LYN	DESCRIPTION	DATE	DWN	APVD
A	66	-	-	SEE SHEET 1	-	-	-

FEED TYPE MECHANICAL

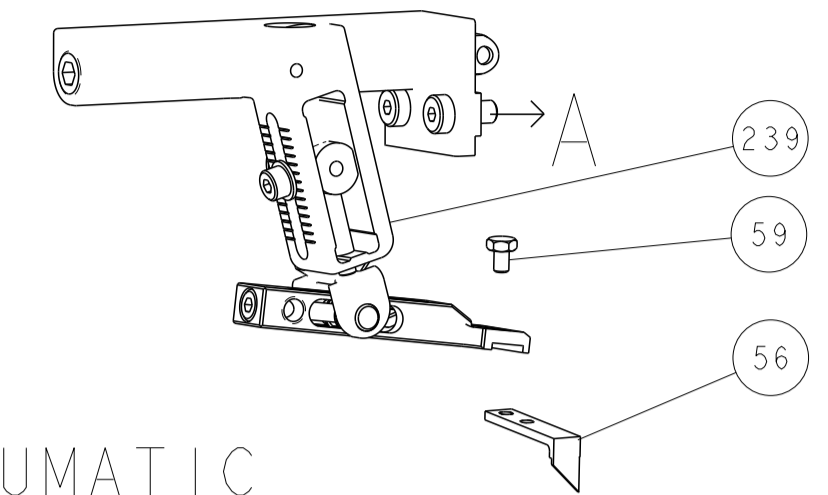

PNEUMATIC

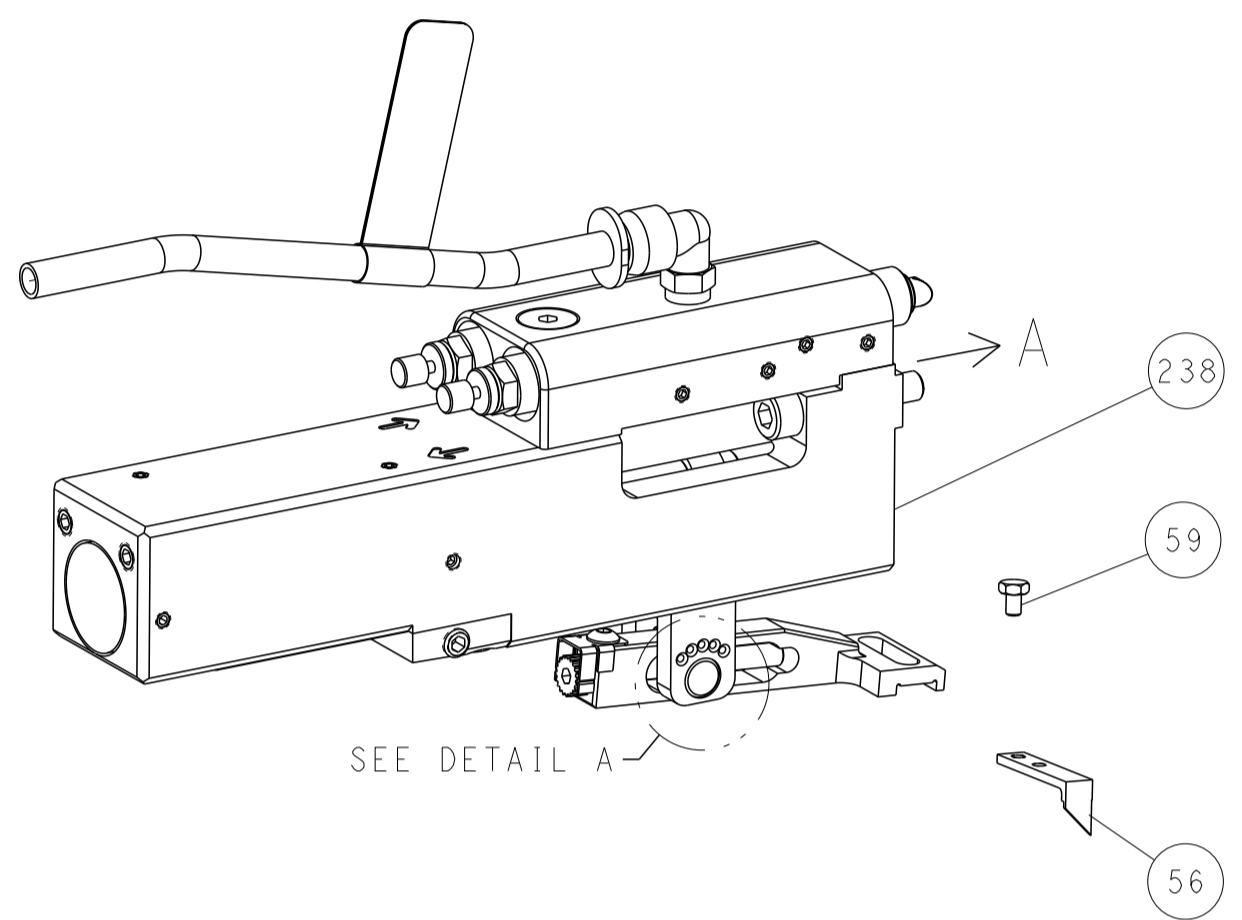

FEED SPRING SETTING POSITION (SHOWN FROM REAR SIDE)



CAM POSITIONS

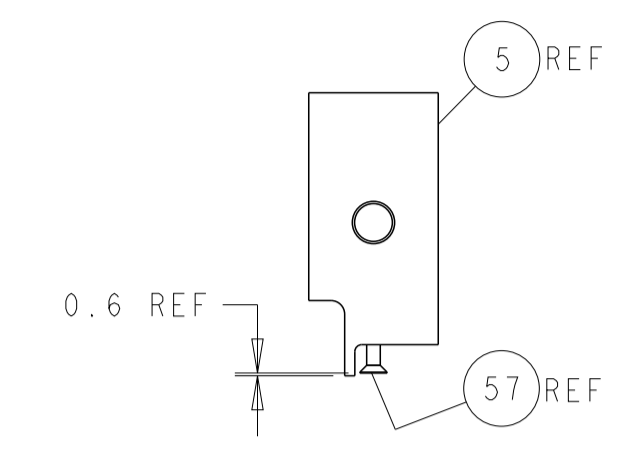
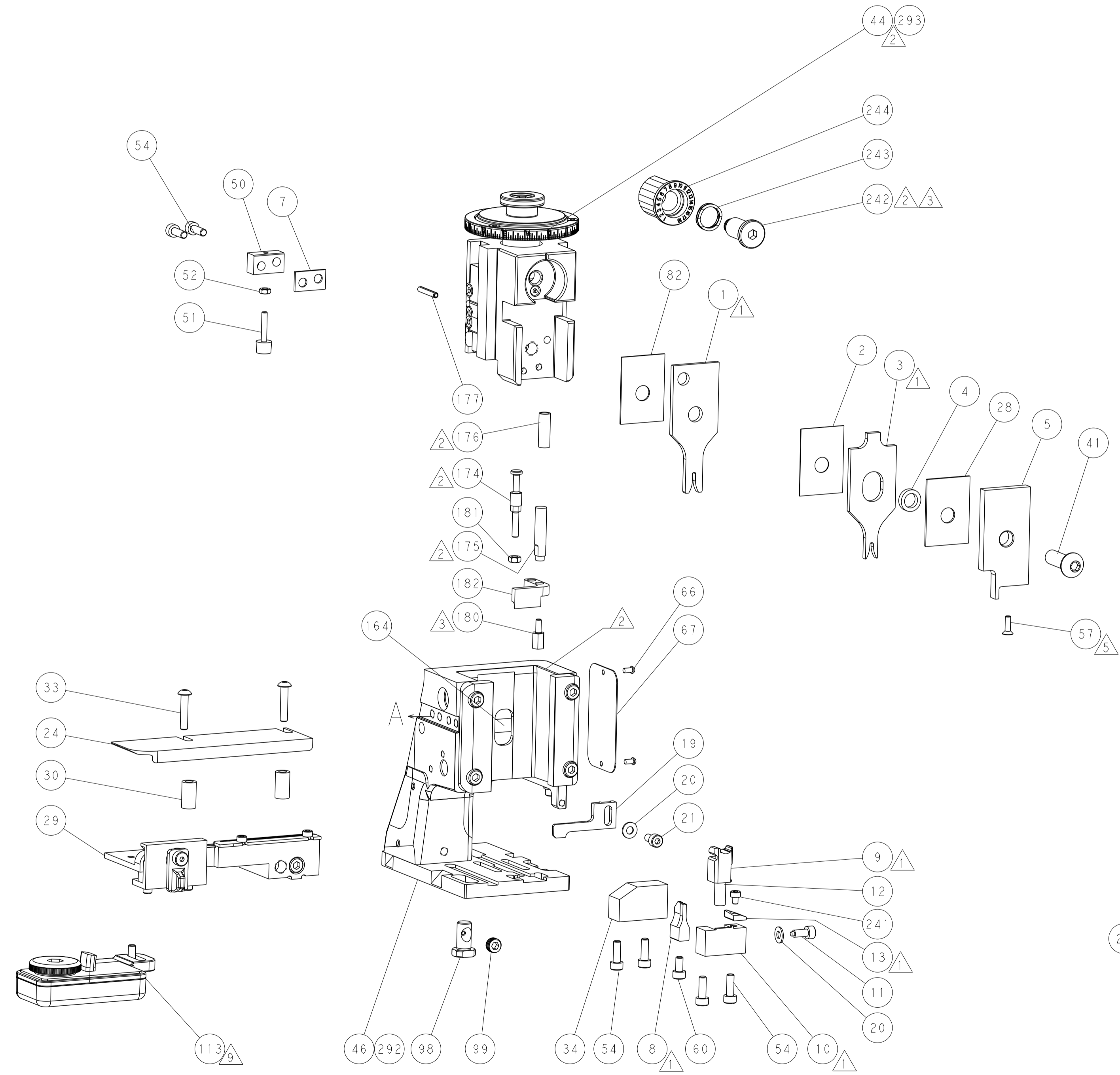
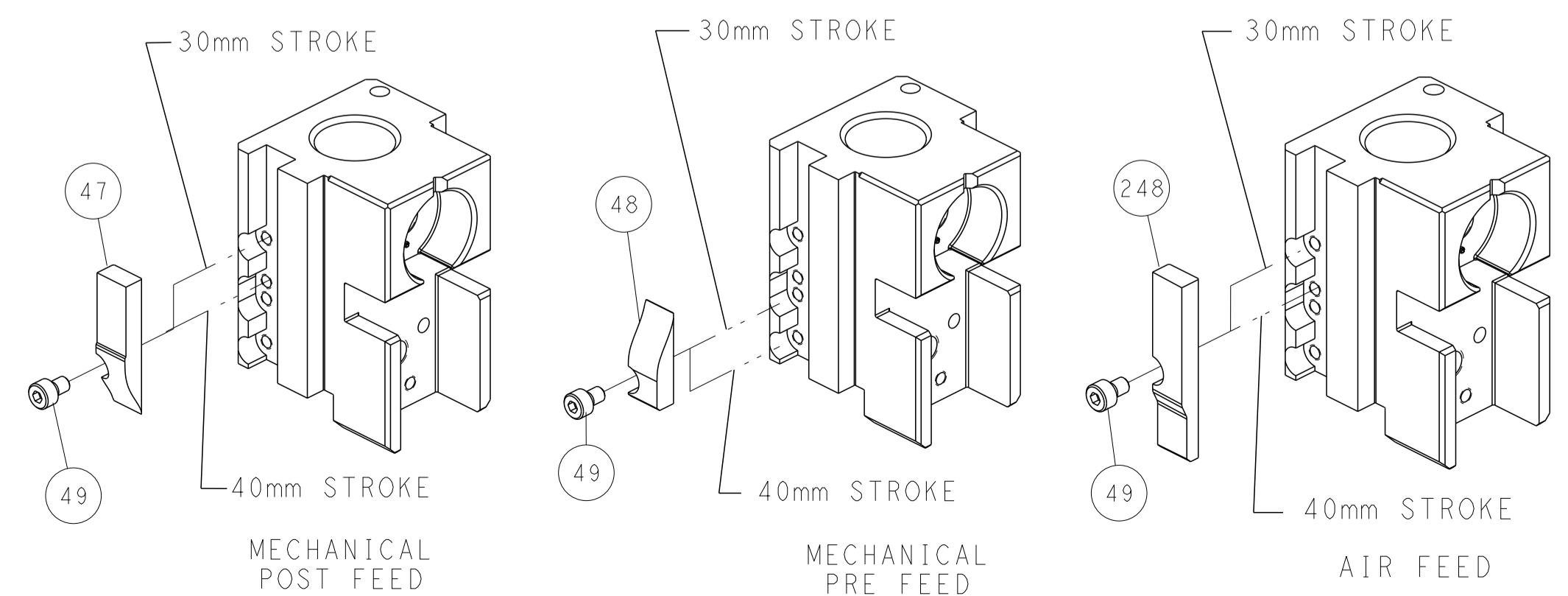

SHEAR DEPRESSOR DETAIL

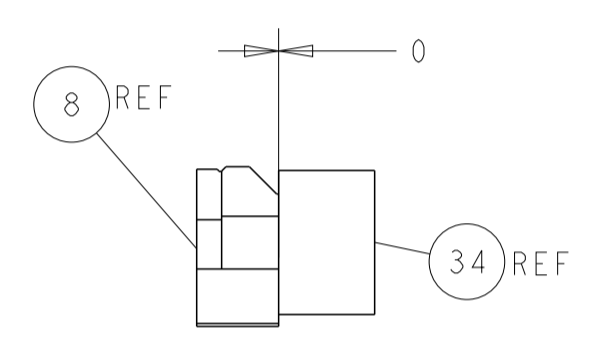

TERMINAL SUPPORT LOCATION

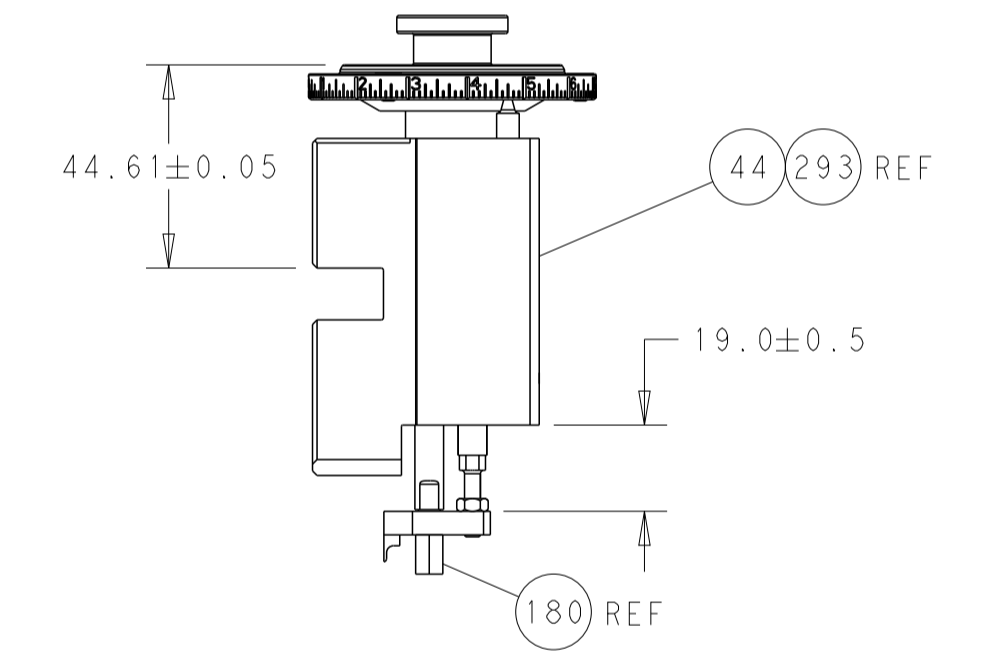

RAM AND HOLD DOWN SET-UP

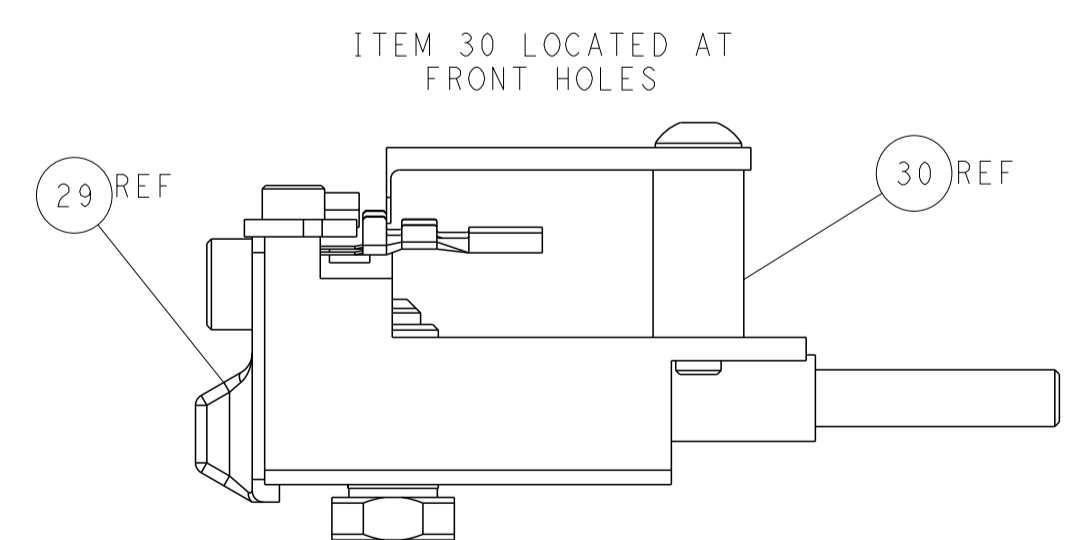

FEED TRACK POSITION GUIDE BY INSULATION BARREL

ATLANTIC VERSION
 Shown on sheets 1 of 4 & 2 of 4
 (Pacific version shown on sheets 3 of 4 & 4 of 4)

DIMENSIONS:		TOLERANCES UNLESS OTHERWISE SPECIFIED:		DWN: R. STAKEM 05JUL2013		TE Connectivity	
mm	0 PLC ±	1 PLC ±	2 PLC ±	3 PLC ±	4 PLC ±	Harrisburg, PA 17105-3608	
MATERIAL:		FINISH:		APVD: T. ELBIN 05JUL2013		NAME: Ocean Side Feed Applicator	
				WEIGHT:		SIZE: A1 00779 C=2151961	
				Customer Accessible Production Drawing		SCALE: 1:2 SHEET 2 OF 4 REV D	

PART NUMBER	REVISION	DESCRIPTION	FEED TYPE
2-2151961-1	D	FINE CRIMP HEIGHT ADJUST	MECHANICAL
2-2151961-2	D	FINE CRIMP HEIGHT ADJUST	PNEUMATIC
7-2151961-7	A	CRIMP TOOLING KIT	-

PACIFIC VERSION TERMINATOR
 INTERFACE ADAPTER



APPLICATOR DATA		
CRIMP	SIZE	TYPE
WIRE	1.45 mm [.057]	F
INSUL	2.19 mm [.086]	O

APPLICATOR INSTRUCTIONS
 408-35042

TERMINAL DATA: SUMITOMO TERMINAL SUMITOMO CRIMP SPECIFICATION	
TERMINAL NAME: 0.64 SEALED FEMALE TERMINAL	
WIRE STRIP LENGTH 3.50-4.50 mm [1.38-.177 IN]	TERMINAL INSULATION DIAMETER RANGE Ø1.20-1.90 mm [0.047-.075 IN]
TERMINAL APPLICATION SPECIFICATION SUMITOMO CONTROL NO. T-211E-H	

TE TERMINAL	SUMITOMO TERMINAL	TE SEAL	SUMITOMO SEAL	SEAL INSULATION DIAMETER RANGE
1949253-1	8100-3455	2113347-1	7165-1198	Ø1.4-1.5mm
1949253-2	8100-3456	1949254-1	7165-1199	Ø1.6-1.7mm
2303723-1	8100-3617	1949996-1	7165-0796	Ø1.2-2.0mm
		3311515-1	7165-1312	Ø1.1-1.4mm

WIRE SIZE	CRIMP HEIGHT mm [INCH]	CRIMP HEIGHT REFERENCE SETTING
0.50mm ²	1.10 +/- 0.05 [0.043 +/- .002]	7.2
0.30mm ²	0.95 +/- 0.05 [0.037 +/- .002]	9.2



- 1 RECOMMENDED SPARE PARTS
- 2 REFER TO SUPPLIED INSTRUCTION SHEET FOR CLEANING, LUBRICATION AND STORAGE OF APPLICATOR.
- 3 APPLY PART NUMBER 2-23419-6 LOCTITE TO THREADS OF ITEMS 242.
- 4 CRIMP HEIGHT REFERENCE SETTING WAS THE SETTING USED WHEN THE APPLICATOR WAS QUALIFIED AT THE FACTORY. ADJUSTMENT MAY BE NECESSARY WHEN RUNNING APPLICATOR IN THE FIELD.
- 5 APPLY TORQ-SEAL IN ALLEN SOCKET TO FILL HOLE AFTER FLAT HD HAS BEEN ADJUSTED TO CORRECT HEIGHT AT QUALIFICATION. APPLY #1-23419-5 LOC-TITE TO THREADS.
- 6 UNLESS SPECIFIED OTHERWISE TORQUE VALUES SHALL BE USED PER DOCUMENT, 101-35000.
- 7 FOR 0.30mm² WIRE SIZE ONLY.
- 8 FOR 0.50mm² WIRE SIZE ONLY.
- 9 TERMINAL LUBRICANT IS RECOMMENDED.

***WARNING**
 ON INSTALLATION, SET WIRE DISC TO CRIMP HEIGHT REFERENCE SETTING FOR LARGEST WIRE SIZE. CRIMP HEIGHT REFERENCE SETTINGS GREATER THAN THE VALUE SHOWN MAY CAUSE DAMAGE TO THE CRIMP TOOLING, REFER TO THE INSTRUCTION SHEET FOR PROPER SETUP AND ADJUSTMENTS.

PACIFIC VERSION
 Shown on sheets 3 of 4 & 4 of 4
 (Atlantic version shown on sheets 1 of 4 & 2 of 4)

LOC	DIST	REVISIONS					
A	66	P	LTN	DESCRIPTION	DATE	OWN	APVD
-	-	-	-	SEE SHEET 1	-	-	-

-	1	1	2119082-8	CAM, SNAIL, INSULATION ADJUSTMENT	244
-	1	1	2079764-1	WASHER, WAVE SPRING, CREST-TO-CREST	243
-	1	1	2119083-1	RETAINER, INSULATION DIAL	242
-	1	1	7-18023-7	SCR, SKT HD CAP M3 X 4.0	241
-	-	1	2119580-1	MECHANICAL FEED ASSEMBLY	239
-	1	-	2844940-1	AIR FEED MODULE	238
-	REF	REF	994970-2	COUNTER, MAGNETIC	164
-	1	-	2119641-2	FEED CAM, AIR FEED	151
-	1	1	2168083-8	SCR, SKT HD CAP, RoHS, M4 X 16	144
-	4	4	2168083-9	SCR, SKT HD CAP, RoHS, M4 X 20	143
-	-	1	2119653-2	FEED CAM, POST FEED	142
-	1	1	1-1803583-0	APPLICATOR BASIC ASSEMBLY, SF	141
-	1	1	1803516-1	RAM ASSEMBLY, SF PACIFIC	140
-	1	1	2119955-1	ASSY, LUBRICATOR, SIDE FEED	113
-	1	1	2844908-1	SCREW, LOCKING	99
-	1	1	2844907-1	POST, LOCKING	98
-	1	1	455888-7	SPACER, CRIMPER	82
-	1	1	1803607-3	DOCUMENTATION PACKAGE	71
-	1	1	2119740-1	TAG, IDENTIFICATION	67
-	2	2	2168078-1	SCREW, DRIVE, RH, RoHS, 2 x .188	66
-	1	1	5-18022-5	SCR, HEX HD CAP, M4 X 6.0	59
-	1	1	985575-3	SCR, FLT SKT HD CAP M3 X 10.0	57
-	1	1	1338685-1	PAWL, FEED	56
-	2	2	2168083-3	SCR, SKT HD CAP, RoHS, M4 X 12.0	53
-	1	1	5018030-1	NUT, HEX, REG, RoHS, M3	52
-	1	1	811242-5	BUMPER, HOLD DOWN	51
-	1	1	690753-2	SPACER, TONKER	50
-	1	2	18023-9	SCR, SKT HD CAP M4 X 6.0	49
-	-	1	2119652-1	FEED CAM, PRE FEED	48
-	1	1	1803602-1	SCR, BHSC, RoHS (M8 X 25)	41
-	1	1	1752356-6	SUPPORT, TERMINAL	34
-	2	2	2079383-5	SCR, BHSC, RoHS (M4 X 20)	33
-	2	2	2-2844962-8	SPACER, CYLINDRICAL, STRIP GUIDE	30
-	1	1	2844992-1	ASSEMBLY, STRIP GUIDE	29
-	1	1	1-455888-0	SPACER, CRIMPER	28
-	1	1	1320928-2	STRIP GUIDE	24
-	1	1	2168083-2	SCR, SKT HD CAP, RoHS, M4 X 8.0	21
-	2	2	1-18028-2	WASHER, FLAT, REG M4	20
-	1	1	2119533-1	STRIPPER, SIDE FEED	19
-	1	1	2119806-1	INSERT, SHEAR	13
-	1	1	3-22280-3	SPRING, COMPRESSION	12
-	1	1	1-356885-4	STOP, SHEAR	11
-	1	1	2119805-1	SHEAR HOLDER, FRONT	10
-	1	1	318707-1	FLOATING SHEAR, FRONT	9
-	1	1	5-1633927-1	ANVIL, COMBINATION	8
-	1	1	3-240641-4	SPACER	7
-	-	-	-	-	6
-	1	1	2119781-1	DEPRESSOR, SHEAR	5
-	1	1	4-238011-0	BLOCK, CRIMPER SPACER	4
-	1	1	2-1803018-5	CRIMPER, INSULATION O	3
-	1	1	455888-4	SPACER, CRIMPER	2
-	1	1	4-1633305-8	CRIMPER, WIRE PREMIUM	1

DIMENSIONS:		TOLERANCES UNLESS OTHERWISE SPECIFIED:		DWG: H. STAKEM 05JUL2013		TE Connectivity Harrisburg, PA 17105-3608	
mm	0 PLC ±	1 PLC ±	2 PLC ±	3 PLC ±	4 PLC ±	APVD: T. ELBIN 05JUL2013	NAME: Ocean Side Feed Applicator
MATERIAL:		FINISH:		WEIGHT:		SCALE: 1:2 SHEET 3 OF 4 REV D	

FEED TYPE MECHANICAL

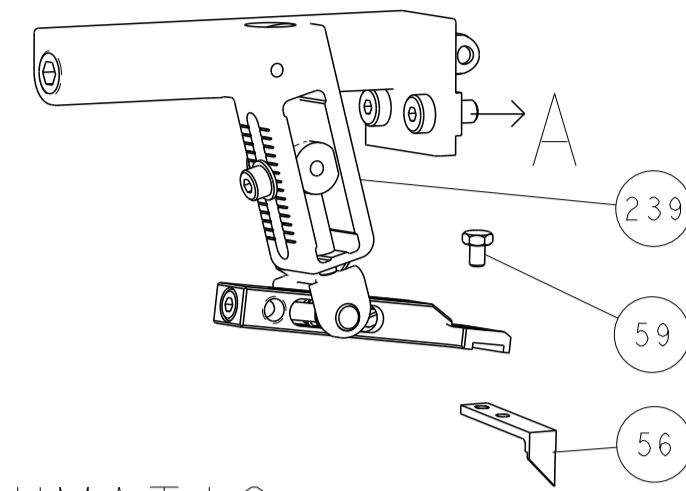

PNEUMATIC

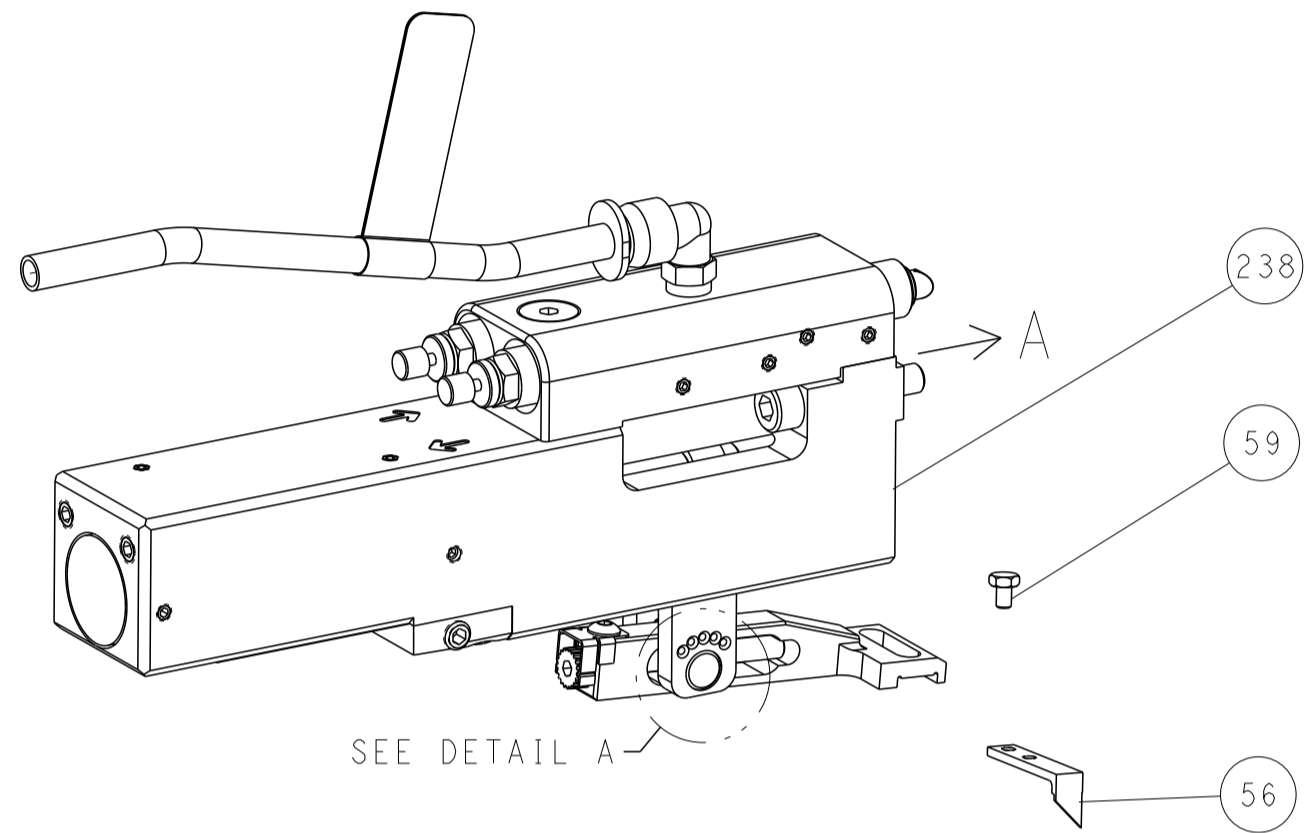

FEED SPRING SETTING POSITION (SHOWN FROM REAR SIDE)

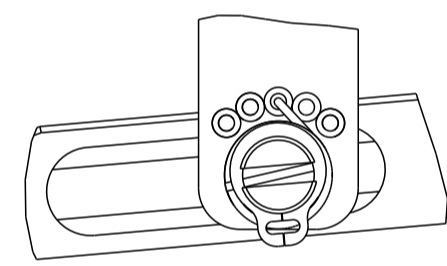

DETAIL A

CAM POSITIONS

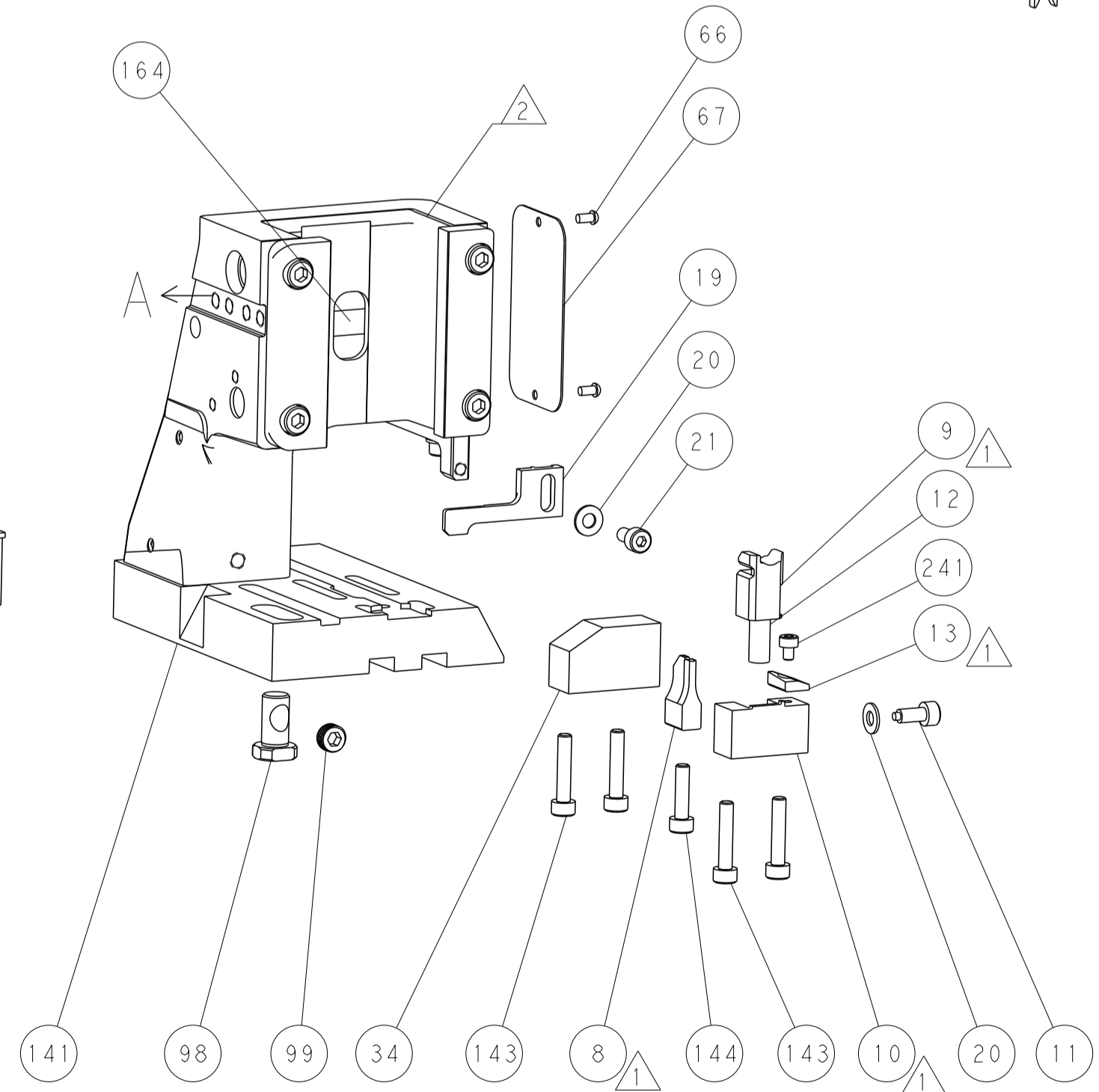
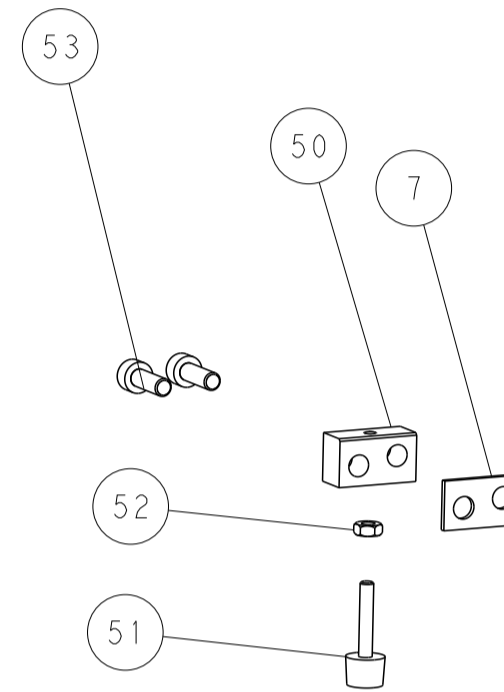
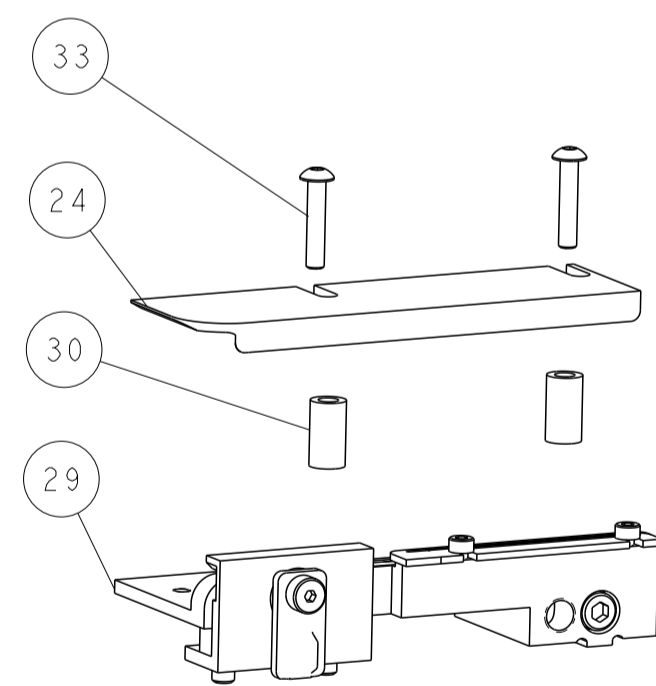
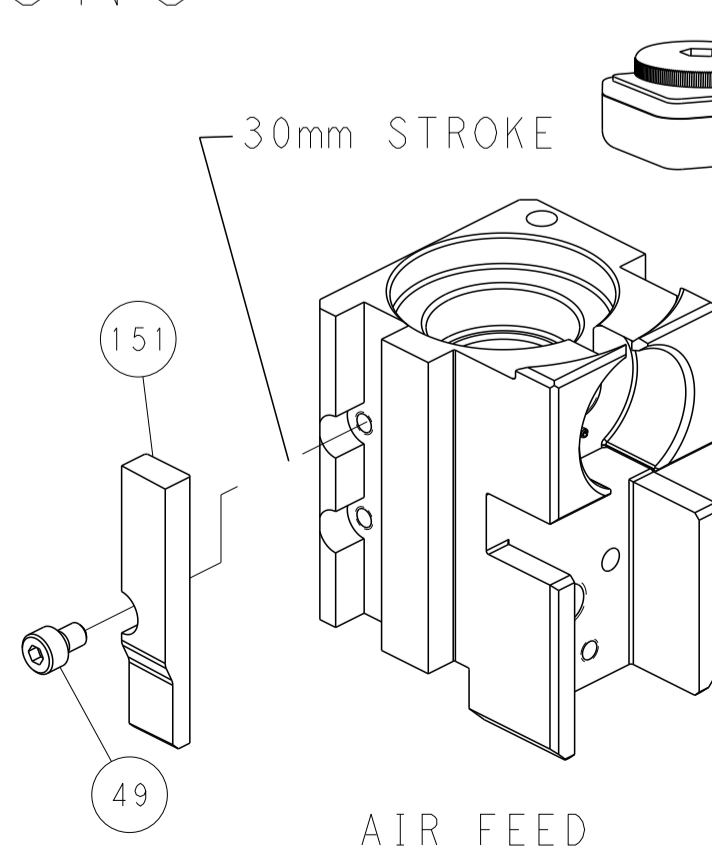
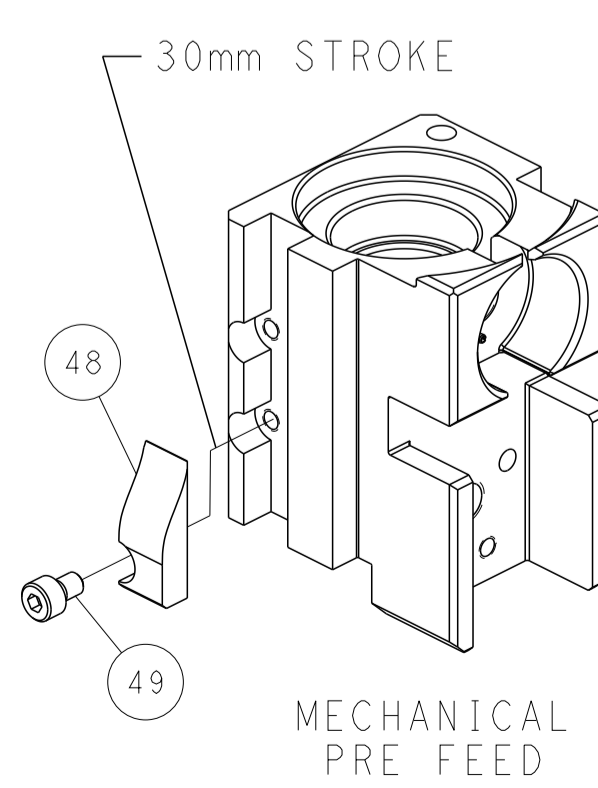
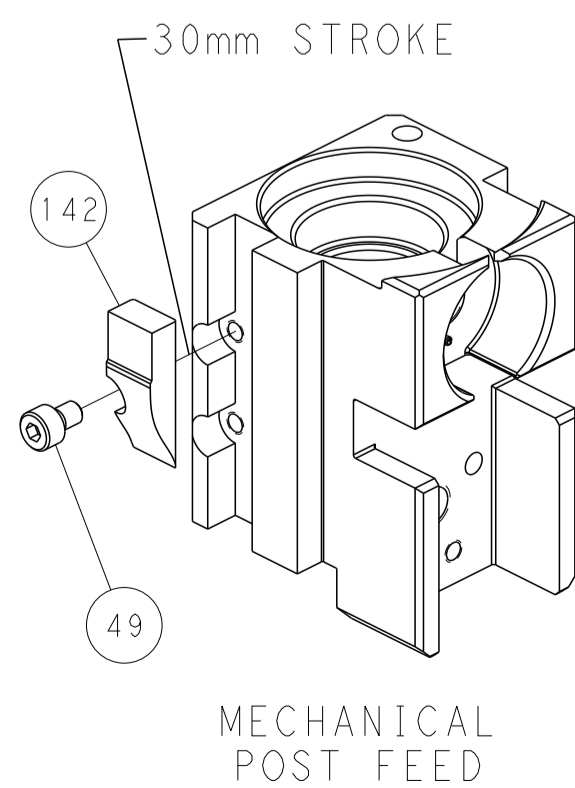

PACIFIC VERSION
Shown on sheets 3 of 4 & 4 of 4
(Atlantic version shown on sheets 1 of 4 & 2 of 4)

LOC	DIST	REVISIONS					
		P	LTN	DESCRIPTION	DATE	DWN	APVD
A	66	-	-	SEE SHEET 1	-	-	-

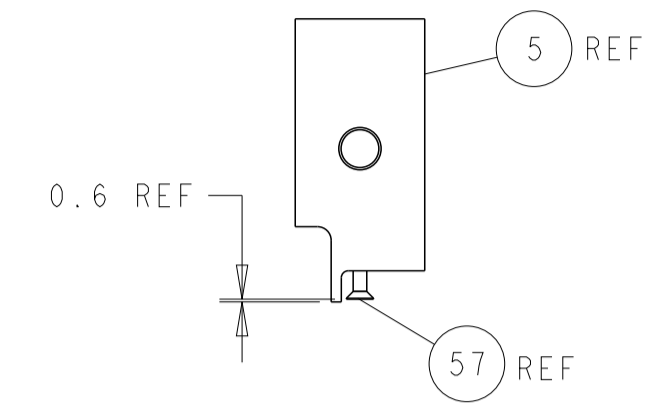

SHEAR DEPRESSOR DETAIL

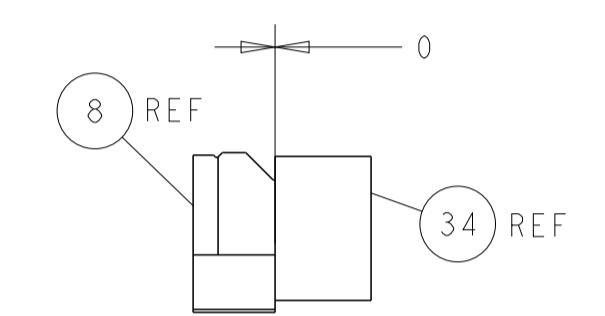

TERMINAL SUPPORT LOCATION

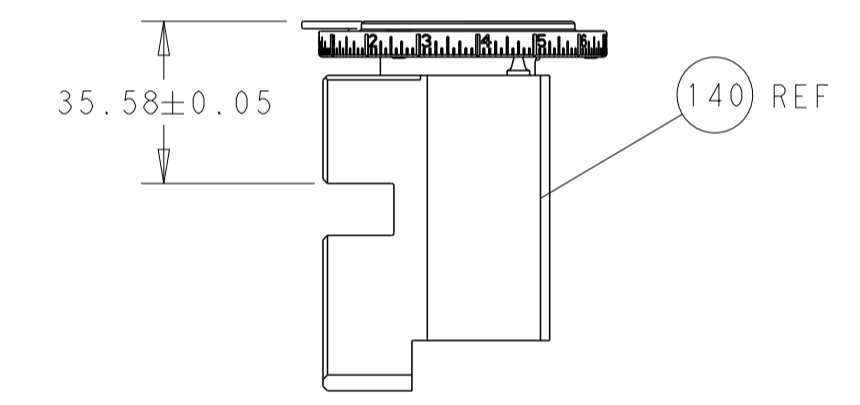

RAM SET-UP

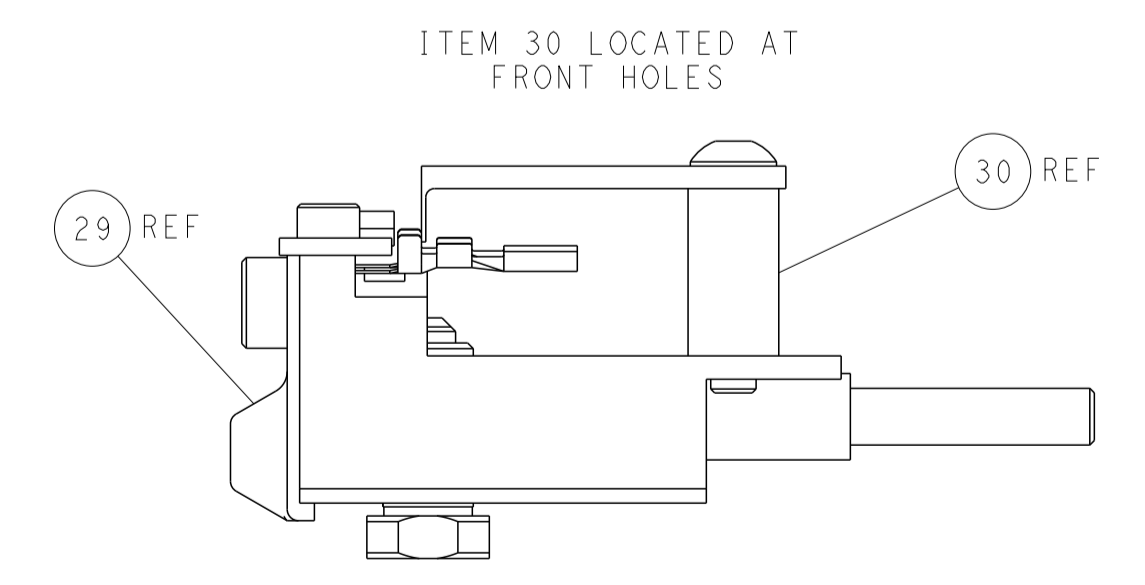

FEED TRACK POSITION GUIDE BY INSULATION BARREL

<small>THIS DRAWING IS UNPUBLISHED. IT IS THE PROPERTY OF TYCOE ELECTRONICS CORPORATION. IT IS TO BE KEPT IN CONFIDENTIALITY AND NOT TO BE REPRODUCED OR TRANSMITTED IN ANY FORM OR BY ANY MEANS, ELECTRONIC OR MECHANICAL, INCLUDING PHOTOCOPYING, RECORDING, OR BY ANY INFORMATION STORAGE AND RETRIEVAL SYSTEM. PERMISSION IS GRANTED TO CONSULT THIS DRAWING FOR THE PURPOSE OF OBTAINING INFORMATION FROM IT. THIS PERMISSION IS LIMITED TO THE INFORMATION CONTAINED HEREIN AND DOES NOT CONSTITUTE AN ENDORSEMENT OR A GUARANTEE OF THE ACCURACY OF THE INFORMATION CONTAINED HEREIN.</small>		DWN: H. STAKEM 05JUL2013 CHK: T. ELBIN 05JUL2013 APVD: T. ELBIN 05JUL2013	TE Connectivity Harrisburg, PA 17105-3608
DIMENSIONS: mm TOLERANCES UNLESS OTHERWISE SPECIFIED: 0 PLC ± 1 PLC ± 2 PLC ± 3 PLC ± 4 PLC ± ANGLES FINISH ±		NAME: Ocean Side Feed Applicator APPLICATION SPEC: - SIZE: A1 CAGE CODE: 00779 DRAWING NO: 2151961	RESTRICTED TO: - SCALE: 1:2 SHEET: 4 OF 4 REV: D
MATERIAL: - FINISH: -		WEIGHT: - Customer Accessible Production Drawing	SHEETS 1 & 2 ARE NOT REQUIRED FOR PACIFIC VERSION