

Housing - HC-B 10-AMQ - 1771325

Please be informed that the data shown in this PDF Document is generated from our Online Catalog. Please find the complete data in the user's documentation. Our General Terms of Use for Downloads are valid (<http://phoenixcontact.com/download>)



HEAVYCON B10 panel mounting base, with double locking latch, height: 29 mm, with flat gasket

RoHS

Key Commercial Data

Packing unit	10 pc
GTIN	
GTIN	4017918036058

Technical data

Dimensions

Height	29 mm
Width	43 mm
Length	93 mm
Length of the assembly cutout	65 mm
Width of the assembly cutout	35 mm

Ambient conditions

Degree of protection of housing (IP)	IP65 (When plugged in)
Ambient temperature (operation)	-40 °C ... 125 °C

General

Note	For contact inserts HC-B10, BB18, DD42, M, K8/24
Size	B10
Housing type	Panel mounting base
Locking type	with double locking latch
Torque	1.5 Nm ... 2 Nm (Mounting screw)
Screw connection	none
Housing material	Aluminum die-cast
Housing surface material	Powder-coated, gray

Housing - HC-B 10-AMQ - 1771325

Technical data

General

Material lock	Stainless steel, handle: PA
Material grip body interlock	PA

Environmental Product Compliance

China RoHS	Environmentally friendly use period: unlimited = EFUP-e
	No hazardous substances above threshold values

Drawings

Dimensional drawing

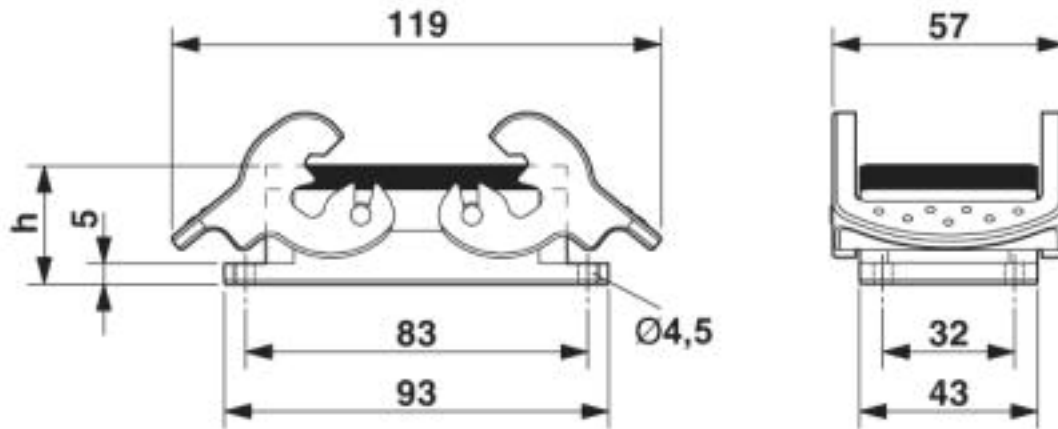

Dimensional drawing

Housing - HC-B 10-AMQ - 1771325

Dimensional drawing

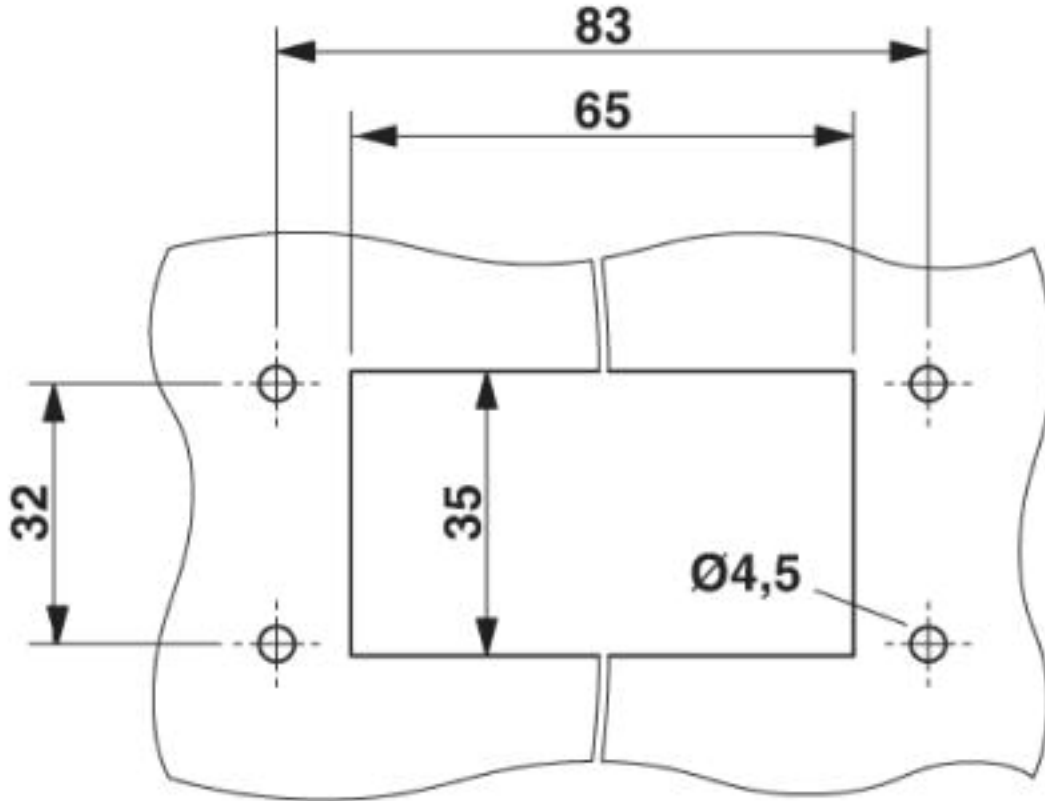

Mounting cutout

Approvals

Approvals

Approvals

EAC

Ex Approvals

Approval details

EAC		RU C- DE.AI30.B.01102
-----	--	--------------------------



Phoenix Contact 2019 © - all rights reserved
<http://www.phoenixcontact.com>

PHOENIX CONTACT GmbH & Co. KG
Flachmarktstr. 8
32825 Blomberg
Germany
Tel. +49 5235 300
Fax +49 5235 3 41200
<http://www.phoenixcontact.com>