

PART NUMBER	REVISION	DESCRIPTION	FEED TYPE
2151517-1	C	FINE CRIMP HEIGHT ADJUST	MECHANICAL
2151517-2	C	FINE CRIMP HEIGHT ADJUST	PNEUMATIC
7-2151517-1	C	MECHANICAL AND CRIMP TOOLING KIT	MECHANICAL
7-2151517-2	C	PNEUMATIC AND CRIMP TOOLING KIT	PNEUMATIC
7-2151517-7	A	CRIMP TOOLING KIT	-

ATLANTIC VERSION TERMINATOR INTERFACE ADAPTER

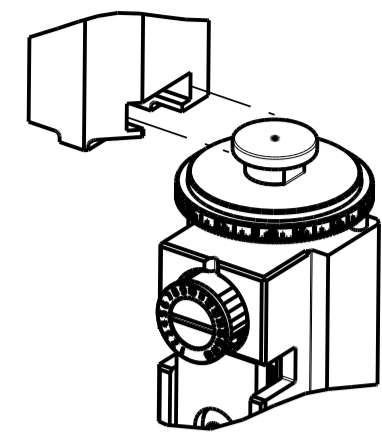

APPLICATOR DATA		
CRIMP	SIZE	TYPE
WIRE	1.07 mm [.042]	F
INSUL	1.57 mm [.062]	O

APPLICATOR INSTRUCTIONS
408-35042

TERMINAL DATA: TE TERMINAL		TE CRIMP SPECIFICATION	
TERMINAL NAME: GET FEMALE TERMINAL, 1.2MM			
WIRE STRIP LENGTH		INSULATION DIAMETER RANGE	
3.30-3.70 mm [.130-.146 IN]		Ø0.80-1.05 mm [.031-.041 IN]	
TERMINAL APPLICATION SPECIFICATION	114-18774		
TERMINALS APPLIED			
TE TERMINAL	TE TERMINAL	TE TERMINAL	TE TERMINAL
1564880-1			

WIRE SIZE	CRIMP HEIGHT mm [INCH]	CRIMP HEIGHT REFERENCE SETTING
0.13mm2	0.62 +/- 0.03 [.024 +/- .001]	7.3

- 1. RECOMMENDED SPARE PARTS
- 2. REFER TO SUPPLIED INSTRUCTION SHEET FOR CLEANING, LUBRICATION AND STORAGE OF APPLICATOR.
- 3. APPLY PART NUMBER 2-23419-6 LOCTITE TO THREADS OF ITEM 242.
- 4. CRIMP HEIGHT REFERENCE SETTING WAS THE SETTING USED WHEN THE APPLICATOR WAS QUALIFIED AT THE FACTORY. ADJUSTMENT MAY BE NECESSARY WHEN RUNNING APPLICATOR IN THE FIELD.
- 5. UNLESS SPECIFIED OTHERWISE TORQUE VALUES SHALL BE USED PER DOCUMENT, 101-35000.

***WARNING**
ON INSTALLATION, SET WIRE DISC TO CRIMP HEIGHT REFERENCE SETTING FOR LARGEST WIRE SIZE. CRIMP HEIGHT REFERENCE SETTINGS GREATER THAN THE VALUE SHOWN MAY CAUSE DAMAGE TO THE CRIMP TOOLING, REFER TO THE INSTRUCTION SHEET FOR PROPER SETUP AND ADJUSTMENTS.

ATLANTIC VERSION
Shown on sheets 1 of 4 & 2 of 4
(Pacific version shown on sheets 3 of 4 & 4 of 4)

LOC	DIST	REVISIONS			
A	66	REV	DATE	BY	APPV
		A	RELEASED	15JAN2014	KH LZ
		B	ECR-19-012041	31JUL2019	FJ RK
		C	ECR-19-019441	13DEC2019	FZ TE
		C1	ECR-21-006079	07JUN2021	LJ YY

-	1	-	1	-	2119641-1	FEED CAM, AIR FEED	248	
-	1	1	1	1	2119082-9	CAM, SNAIL, INSULATION ADJUSTMENT	244	
-	1	1	1	1	2079764-1	WASHER, WAVE SPRING, CREST-TO-CREST	243	
-	1	1	1	1	2119083-1	RETAINER, INSULATION DIAL	242	
-	1	1	1	1	7-18023-7	SCR, SKT HD CAP M3 X 4.0	241	
-	-	1	-	1	2119580-1	MECHANICAL FEED ASSEMBLY	239	
-	1	-	1	-	2844940-1	AIR FEED MODULE	238	
-	REF	REF	REF	REF	994970-2	COUNTER, MAGNETIC	164	
-	1	1	1	1	1-22281-8	SPRING, COMPRESSION	121	
-	1	1	1	1	1-18028-2	WASHER, FLAT, REG M4	119	
-	1	1	1	1	2844908-1	SCREW, LOCKING	99	
-	1	1	1	1	2844907-1	POST, LOCKING	98	
-	1	1	1	1	1-690438-0	FRONT STRIP GUIDE	96	
-	2	2	2	2	2168083-1	SCR, SKT HD CAP, RoHS, M3 X 8.0	95	
-	1	1	1	1	2168083-6	SCR, SKT HD CAP, RoHS, M5 X 65	93	
-	1	1	1	1	455888-5	SPACER, CRIMPER	82	
-	1	1	1	1	5-547505-2	SPRING, COMPRESSION	77	
-	1	1	1	1	854769-4	HOLDER, INS	74	
-	1	1	1	1	1803607-3	DOCUMENTATION PACKAGE	71	
-	1	1	1	1	2119740-1	TAG, IDENTIFICATION	67	
-	2	2	2	2	2168078-1	SCREW, DRIVE, RH, RoHS, 2 x .188	66	
-	2	2	2	2	2-18032-5	SCR, SET, FLT PNT, M5 X 20.0	61	
-	1	1	1	1	2168083-2	SCR, SKT HD CAP, RoHS, M4 X 8.0	60	
-	1	1	1	1	5-18022-5	SCR, HEX HD CAP, M4 X 6.0	59	
-	1	1	1	1	21028-2	PIN, SLOTTED SPRING .062 X .250	58	
-	1	1	1	1	1338685-1	PAWL, FEED	56	
-	4	4	4	4	2168083-3	SCR, SKT HD CAP, RoHS, M4 X 12.0	54	
-	2	2	2	2	1-2168083-0	SCR, SKT HD CAP, RoHS, M4 X 10	53	
-	1	1	1	1	1803382-6	HOLD DOWN, SPRING LOADED	50	
-	1	2	1	2	18023-9	SCR, SKT HD CAP M4 X 6.0	49	
-	-	1	-	1	2119652-1	FEED CAM, PRE FEED	48	
-	-	1	-	1	2119653-1	FEED CAM, POST FEED	47	
-	1	1	1	1	1803583-9	APPLICATOR BASIC ASSEMBLY, SF	46	
-	1	1	1	1	1803515-1	RAM ASSEMBLY, SF ATLANTIC	44	
-	1	1	1	1	1803602-1	SCR, BHSC, RoHS (M8 X 25)	41	
-	1	1	1	1	1752356-3	SUPPORT, TERMINAL	34	
-	2	2	2	2	2079383-5	SCR, BHSC, RoHS (M4 X 20)	33	
-	2	2	2	2	2-2844962-3	SPACER, CYLINDRICAL, STRIP GUIDE	30	
-	1	1	1	1	2844938-5	PLATE, STRIP GUIDE	29	
-	1	1	1	1	455888-3	SPACER, CRIMPER	28	
-	2	2	2	2	22283-1	SPRING, COMPRESSION	27	
-	1	1	1	1	356835-1	LEVER, DRAG RELEASE	26	
-	1	1	1	1	240792-1	DRAG, TERMINAL	25	
-	1	1	1	1	1320928-2	STRIP GUIDE	24	
-	1	1	1	1	980371-4	SCR, SKT HD SHLDR 5.0 DIA X 6.0	23	
-	1	1	1	1	2168083-2	SCR, SKT HD CAP, RoHS, M4 X 8.0	21	
-	1	1	1	1	1-18028-2	WASHER, FLAT, REG M4	20	
-	1	1	1	1	2119533-1	STRIPPER, SIDE FEED	19	
-	1	1	1	1	2119806-1	INSERT, SHEAR	13	
-	1	1	1	1	3-22280-3	SPRING, COMPRESSION	12	
-	1	1	1	1	1-356885-4	STOP, SHEAR	11	
-	1	1	1	1	2119805-1	SHEAR HOLDER, FRONT	10	
-	1	1	1	1	1803095-5	FLOATING SHEAR, FRONT	9	
-	1	2	2	1	1-1633127-6	ANVIL, COMBINATION .042	8	
-	-	-	-	-	-	-	7	
-	-	-	-	-	-	-	6	
-	1	1	1	1	2119780-9	DEPRESSOR, SHEAR	5	
-	1	1	1	1	238011-7	BLOCK, CRIMPER SPACER	4	
-	1	2	2	1	1-1633966-6	CRIMPER, INSULATION O	3	
-	1	1	1	1	455888-8	SPACER, CRIMPER	2	
-	1	2	2	1	2-456401-1	CRIMPER, WIRE .042 F PREMIUM	1	
-	77	72	71	2	-1	PART NO	DESCRIPTION	ITEM NO

DIMENSIONS:		TOLERANCES UNLESS OTHERWISE SPECIFIED:		MATERIAL:		FINISH:		WEIGHT:		SCALE:	
mm	0 PLC ±	1 PLC ±	2 PLC ±	3 PLC ±	4 PLC ±	ANGLES	FINISH	WEIGHT	SCALE	SHEET	REV
										1	C1

LOC		DIST		REVISIONS			
A	66	P	LTM	DESCRIPTION	DATE	DWN	APVD
		-		SEE SHEET 1			

FEED TYPE MECHANICAL

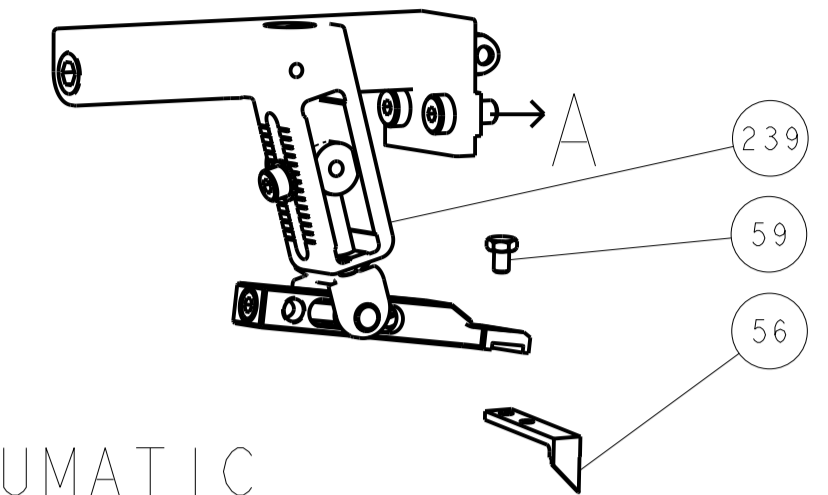

PNEUMATIC

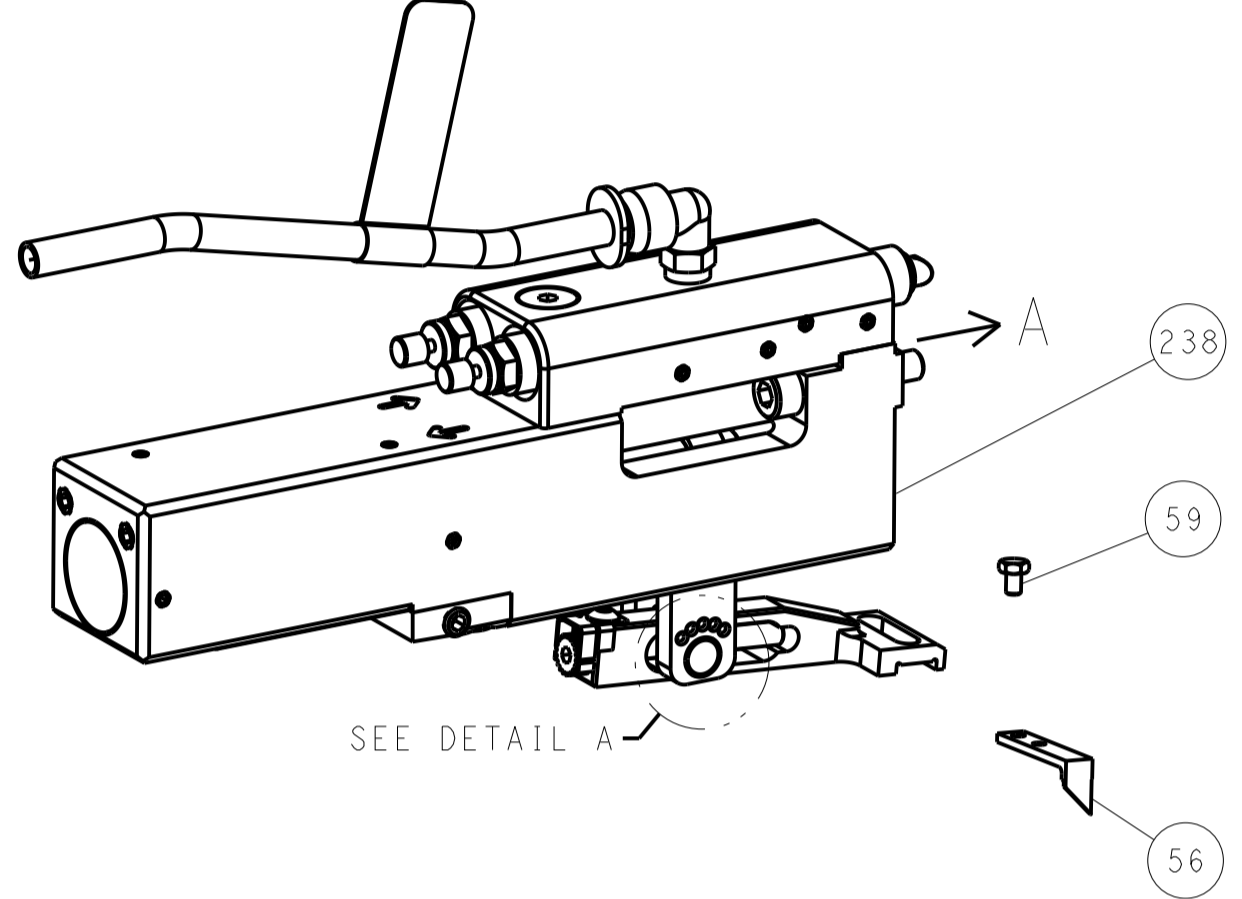

FEED SPRING SETTING POSITION (SHOWN FROM REAR SIDE)

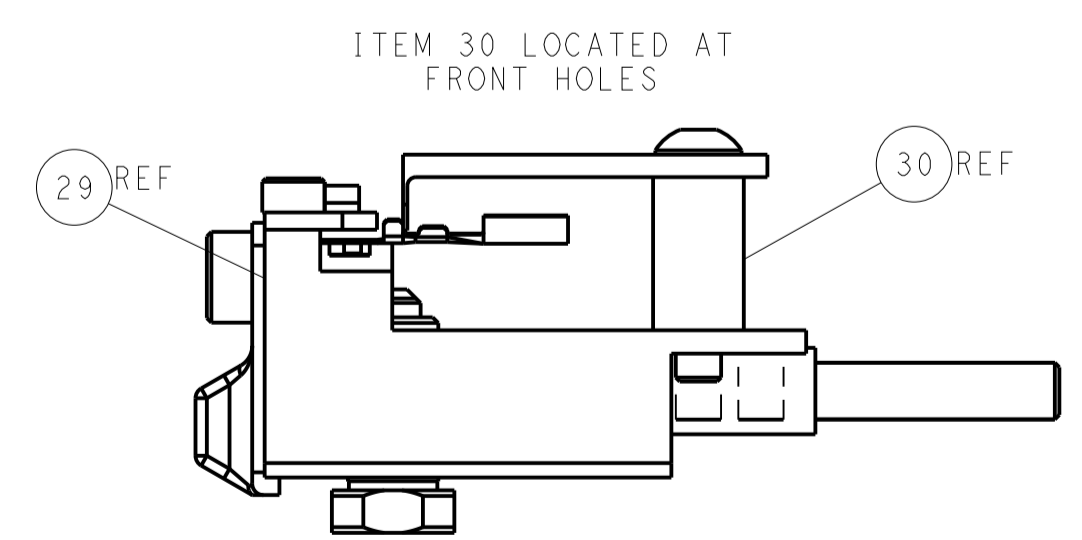
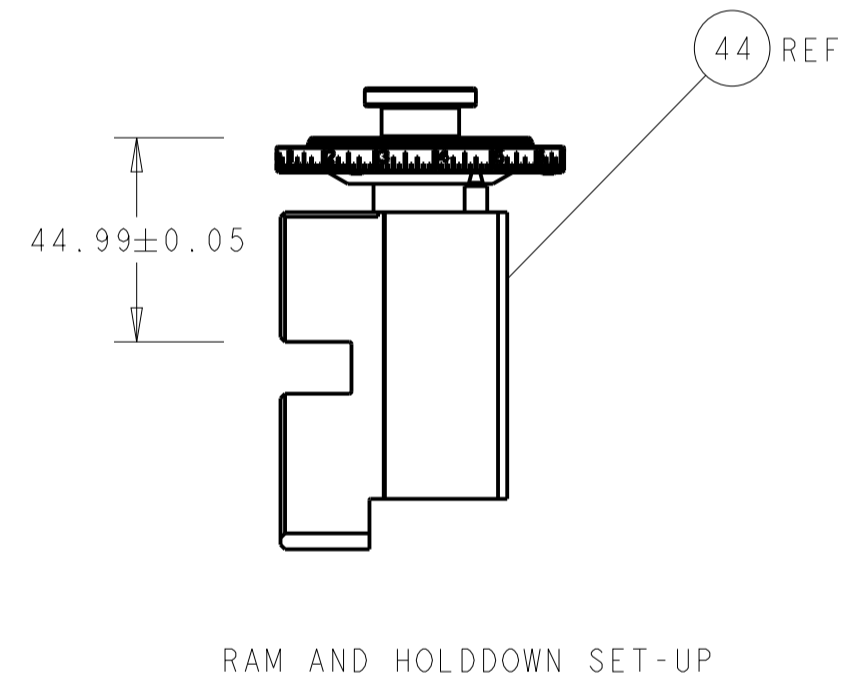
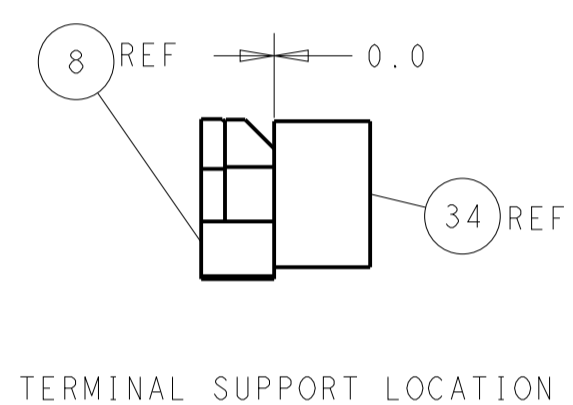
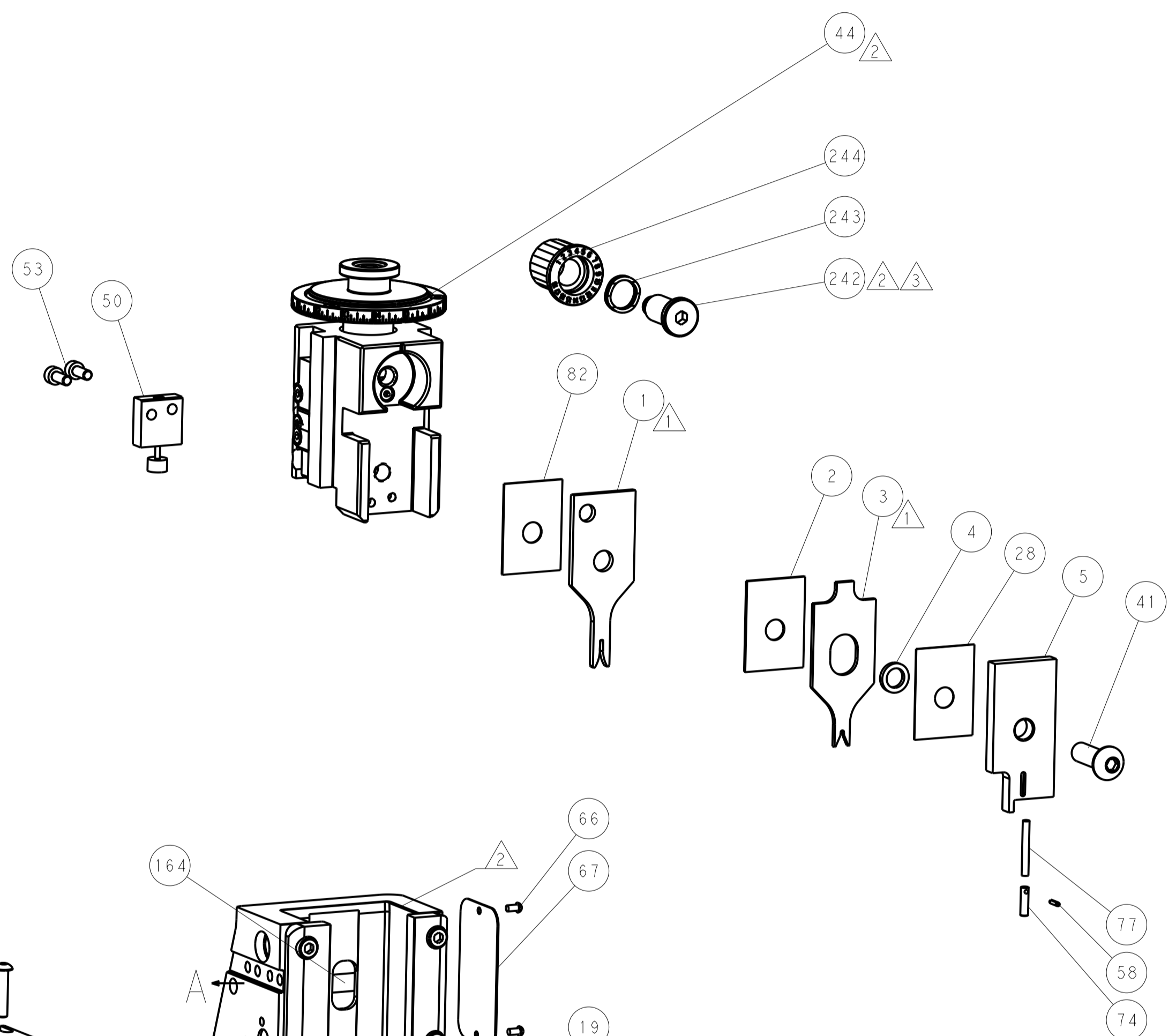
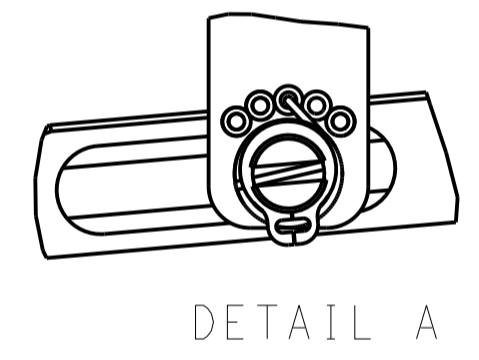

CAM POSITIONS

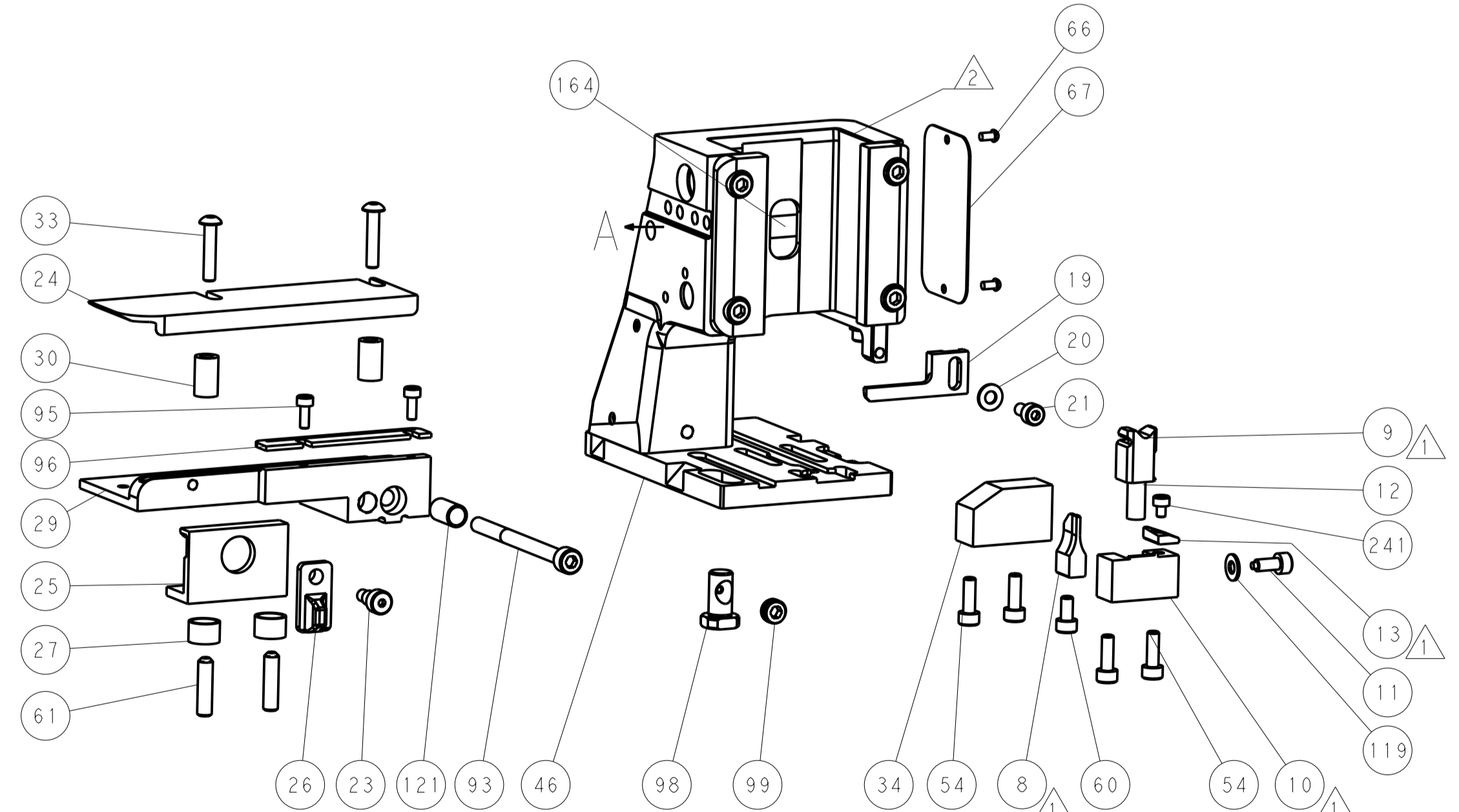
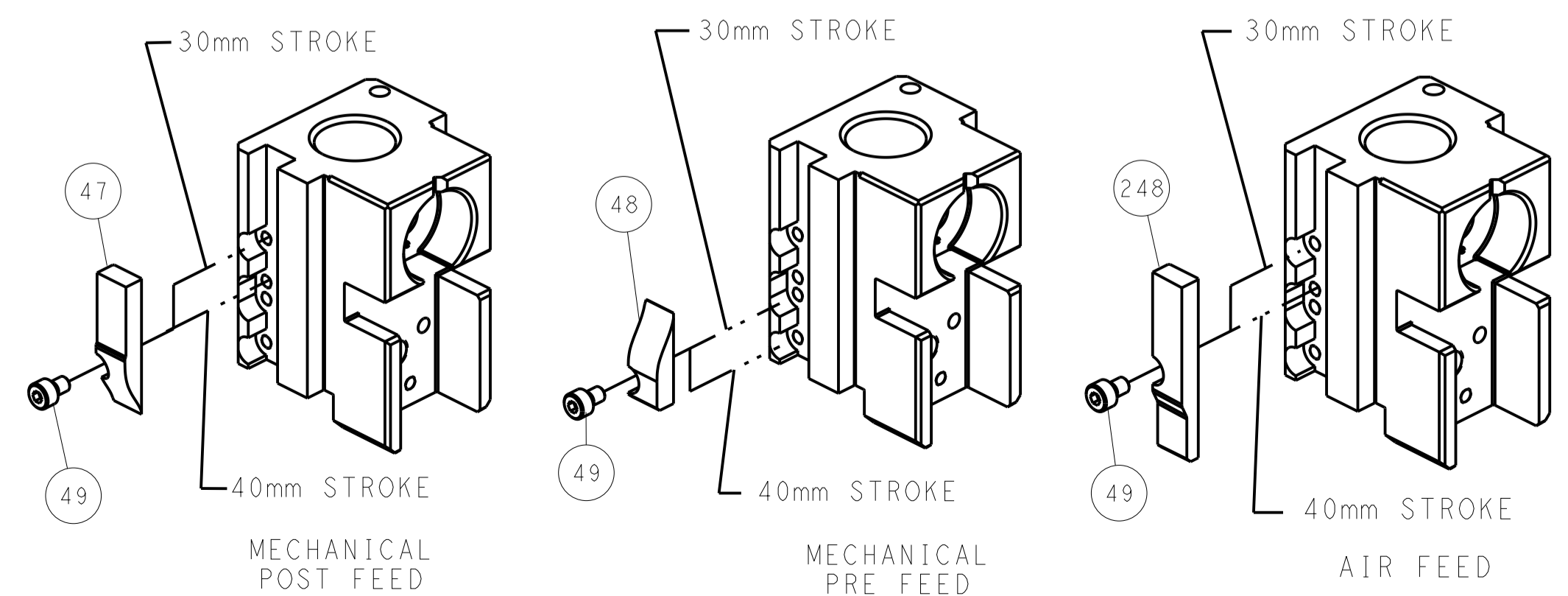

ATLANTIC VERSION
 Shown on sheets 1 of 4 & 2 of 4
 (Pacific version shown on sheets 3 of 4 & 4 of 4)

DIMENSIONS:		TOLERANCES UNLESS OTHERWISE SPECIFIED:		DWN 01JAN2012		TE Connectivity	
mm	0 PLC ±	1 PLC ±	2 PLC ±	3 PLC ±	4 PLC ±	Harrisburg, PA 17105-3608	
MATERIAL:		FINISH:		CHK 01JAN2012		NAME	
				L. ZHANG		Ocean Side Feed Applicator	
				H. GUO 01JAN2012		SIZE CAGE CODE DRAWING NO	
				APVD		RESTRICTED TO	
				PRODUCT SPEC		A 00779 ©=2151517	
				APPLICATION SPEC		Customer Accessible Production Drawing	
				WEIGHT		SCALE 1:2 SHEET 2 OF 4 REV C1	

PART NUMBER	REVISION	DESCRIPTION	FEED TYPE
2-2151517-1	C	FINE CRIMP HEIGHT ADJUST	MECHANICAL
2-2151517-2	C	FINE CRIMP HEIGHT ADJUST	PNEUMATIC
7-2151517-7	A	CRIMP TOOLING KIT	-

PACIFIC VERSION TERMINATOR
 INTERFACE ADAPTER

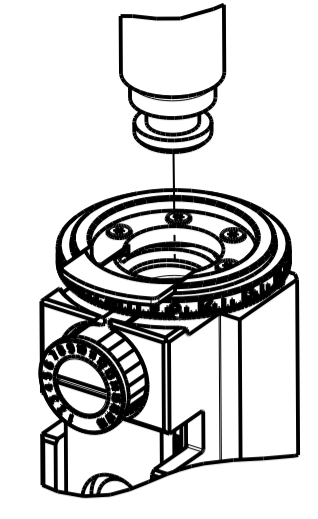

APPLICATOR DATA		
CRIMP	SIZE	TYPE
WIRE	1.07 mm [.042]	F
INSUL	1.57 mm [.062]	O

APPLICATOR INSTRUCTIONS
 408-35042

TERMINAL DATA: TE TERMINAL		TE CRIMP SPECIFICATION	
TERMINAL NAME: GET FEMALE TERMINAL, 1.2MM			
WIRE STRIP LENGTH		INSULATION DIAMETER RANGE	
3.30-3.70 mm [1.30-.146 IN]		Ø0.80-1.05 mm [.031-.041 IN]	
TERMINAL APPLICATION SPECIFICATION	114-18774		

TERMINALS APPLIED			
TE TERMINAL	TE TERMINAL	TE TERMINAL	TE TERMINAL
1564880-1			

WIRE SIZE	CRIMP HEIGHT mm [INCH]	CRIMP HEIGHT REFERENCE SETTING
0.13mm2	0.62 +/- 0.03 [.024 +/- .001]	7.3



- 1 RECOMMENDED SPARE PARTS
 - 2 REFER TO SUPPLIED INSTRUCTION SHEET FOR CLEANING, LUBRICATION AND STORAGE OF APPLICATOR.
 - 3 APPLY PART NUMBER 2-23419-6 LOCTITE TO THREADS OF ITEM 242.
 - 4 CRIMP HEIGHT REFERENCE SETTING WAS THE SETTING USED WHEN THE APPLICATOR WAS QUALIFIED AT THE FACTORY. ADJUSTMENT MAY BE NECESSARY WHEN RUNNING APPLICATOR IN THE FIELD.
5. UNLESS SPECIFIED OTHERWISE TORQUE VALUES SHALL BE USED PER DOCUMENT, 101-35000.

ENTRY LEVEL APPLICATOR		ITEM SUBSTITUTION LIST		
PART NUMBER	SAME AS	ITEM	ITEM DESCRIPTION	SUBSTITUTE PART NUMBER
8-2151517-1	2151517-1	1	WIRE CRIMPER	2-1803660-1
8-2151517-2	2151517-2	3	INSULATION CRIMPER	1-1803599-6
9-2151517-1	2-2151517-1	46	BASIC SUB -ASSEMBLY	1803940-9
9-2151517-2	2-2151517-2	141	BASIC SUB -ASSEMBLY	1-1803940-0
			LUBRICATOR	DELETE

***WARNING**
 ON INSTALLATION, SET WIRE DISC TO CRIMP HEIGHT REFERENCE SETTING FOR LARGEST WIRE SIZE. CRIMP HEIGHT REFERENCE SETTINGS GREATER THAN THE VALUE SHOWN MAY CAUSE DAMAGE TO THE CRIMP TOOLING, REFER TO THE INSTRUCTION SHEET FOR PROPER SETUP AND ADJUSTMENTS.

PACIFIC VERSION
 Shown on sheets 3 of 4 & 4 of 4
 (Atlantic version shown on sheets 1 of 4 & 2 of 4)

LOC	DIST	REV	DATE	BY	APPV
A	66				

REVISIONS						
REV	DATE	DESCRIPTION	DATE	BY	APPV	
-	-	SEE SHEET 1	-	-	-	
-	1	1	2119082-9	CAM, SNAIL, INSULATION ADJUSTMENT	244	
-	1	1	2079764-1	WASHER, WAVE SPRING, CREST-TO-CREST	243	
3	-	1	1	2119083-1	RETAINER, INSULATION DIAL	242
-	1	1	7-18023-7	SCR, SKT HD CAP M3 X 4.0	241	
-	-	1	2119580-1	MECHANICAL FEED ASSEMBLY	239	
-	1	-	2844940-1	AIR FEED MODULE	238	
-	REF	REF	994970-2	COUNTER, MAGNETIC	164	
-	1	-	2119641-2	FEED CAM, AIR FEED	151	
-	1	1	2168083-8	SCR, SKT HD CAP, RoHS, M4 X 16	144	
-	4	4	2168083-9	SCR, SKT HD CAP, RoHS, M4 X 20	143	
-	-	1	2119653-2	FEED CAM, POST FEED	142	
-	1	1	1-1803583-0	APPLICATOR BASIC ASSEMBLY, SF	141	
-	1	1	1803516-1	RAM ASSEMBLY, SF PACIFIC	140	
-	1	1	1-22281-8	SPRING, COMPRESSION	121	
-	1	1	1-18028-2	WASHER, FLAT, REG M4	119	
-	1	1	2844908-1	SCREW, LOCKING	99	
-	1	1	2844907-1	POST, LOCKING	98	
-	1	1	1-690438-0	FRONT STRIP GUIDE	96	
-	2	2	2168083-1	SCR, SKT HD CAP, RoHS, M3 X 8.0	95	
-	1	1	2168083-6	SCR, SKT HD CAP, RoHS, M5 X 65	93	
-	1	1	455888-5	SPACER, CRIMPER	82	
-	1	1	5-547505-2	SPRING, COMPRESSION	77	
-	1	1	854769-4	HOLDER, INS	74	
-	1	1	1803607-3	DOCUMENTATION PACKAGE	71	
-	1	1	2119740-1	TAG, IDENTIFICATION	67	
-	2	2	2168078-1	SCREW, DRIVE, RH, RoHS, 2 x .188	66	
-	2	2	2-18032-5	SCR, SET, FLT PNT, M5 X 20.0	61	
-	1	1	5-18022-5	SCR, HEX HD CAP, M4 X 6.0	59	
-	1	1	21028-2	PIN, SLOTTED SPRING .062 X .250	58	
-	1	1	1338685-1	PAWL, FEED	56	
-	2	2	1-2168083-0	SCR, SKT HD CAP, RoHS, M4 X 10	53	
-	1	1	1803382-6	HOLD DOWN, SPRING LOADED	50	
-	1	2	18023-9	SCR, SKT HD CAP M4 X 6.0	49	
-	-	1	2119652-1	FEED CAM, PRE FEED	48	
-	1	1	1803602-1	SCR, BHSC, RoHS (M8 X 25)	41	
-	1	1	1752356-3	SUPPORT, TERMINAL	34	
-	2	2	2079383-5	SCR, BHSC, RoHS (M4 X 20)	33	
-	2	2	2-2844962-3	SPACER, CYLINDRICAL, STRIP GUIDE	30	
-	1	1	2844938-5	PLATE, STRIP GUIDE	29	
-	1	1	455888-3	SPACER, CRIMPER	28	
-	2	2	22283-1	SPRING, COMPRESSION	27	
-	1	1	356835-1	LEVER, DRAG RELEASE	26	
-	1	1	240792-1	DRAG, TERMINAL	25	
-	1	1	1320928-2	STRIP GUIDE	24	
-	1	1	980371-4	SCR, SKT HD SHLDR 5.0 DIA X 6.0	23	
-	1	1	2168083-2	SCR, SKT HD CAP, RoHS, M4 X 8.0	21	
-	1	1	1-18028-2	WASHER, FLAT, REG M4	20	
-	1	1	2119533-1	STRIPPER, SIDE FEED	19	
3	-	1	1	2119806-1	INSERT, SHEAR	13
-	1	1	3-22280-3	SPRING, COMPRESSION	12	
-	1	1	1-356885-4	STOP, SHEAR	11	
-	1	1	2119805-1	SHEAR HOLDER, FRONT	10	
-	1	1	1803095-5	FLOATING SHEAR, FRONT	9	
3	1	1	1	1-1633127-6	ANVIL, COMBINATION .042	8
-	-	-	-	-	7	
-	-	-	-	-	6	
-	1	1	2119780-9	DEPRESSOR, SHEAR	5	
-	1	1	238011-7	BLOCK, CRIMPER SPACER	4	
3	1	1	1	1-1633966-6	CRIMPER, INSULATION O	3
-	1	1	1	455888-8	SPACER, CRIMPER	2
3	1	1	1	2-456401-1	CRIMPER, WIRE .042 F PREMIUM	1

DIMENSIONS: mm 		TOLERANCES UNLESS OTHERWISE SPECIFIED: 0 PLC ± 1 PLC ± 2 PLC ± 3 PLC ± 4 PLC ± ANGLES ±		DWN L. HUANG 01JAN2012 CHK L. ZHANG 01JAN2012 APVD H. GUO 01JAN2012		TE Connectivity Harrisburg, PA 17105-3608	
MATERIAL:		FINISH:		WEIGHT:		SCALE: 1:2 SHEET 3 OF 4 REV C1	
PRODUCT SPEC:				APPLICATION SPEC:			
SIZE: 00779 C=2151517				RESTRICTED TO:			

LOC		DIST		REVISIONS			
A	66	P	LTM	DESCRIPTION	DATE	DWN	APVD
		-		SEE SHEET 1			

FEED TYPE MECHANICAL

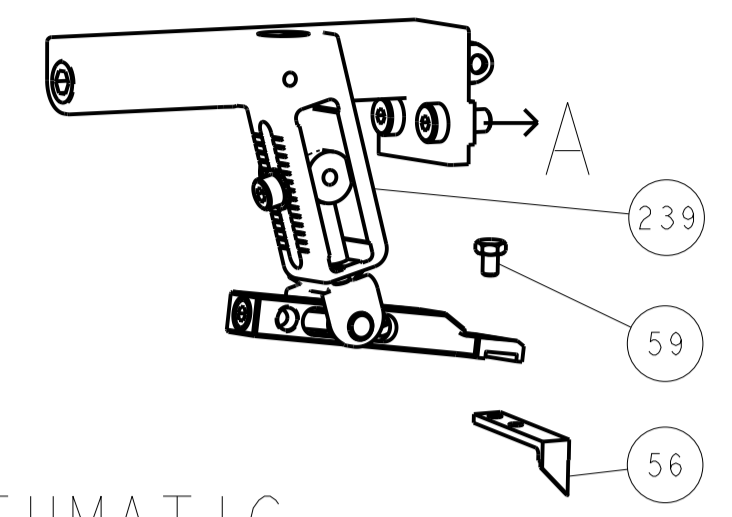

PNEUMATIC

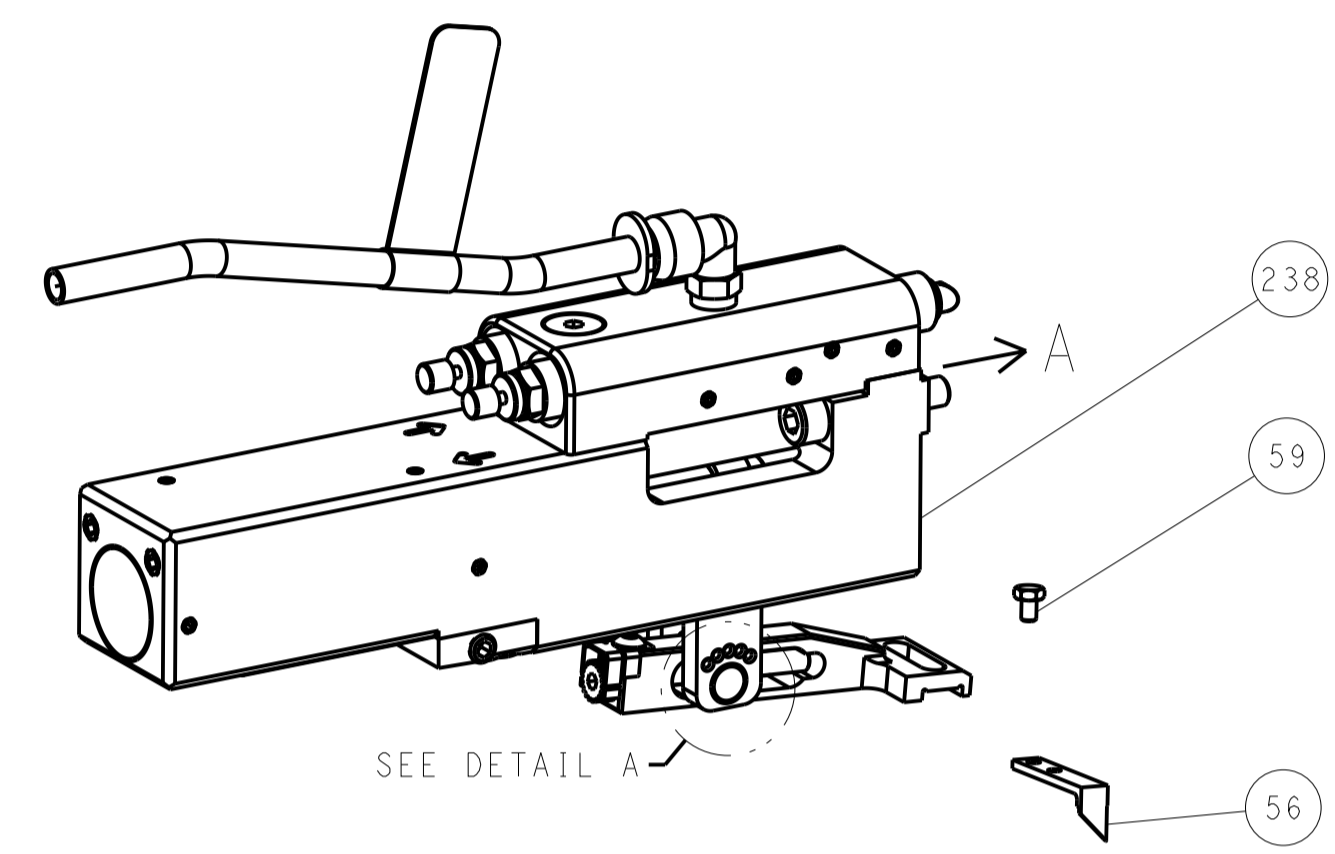

FEED SPRING SETTING POSITION (SHOWN FROM REAR SIDE)

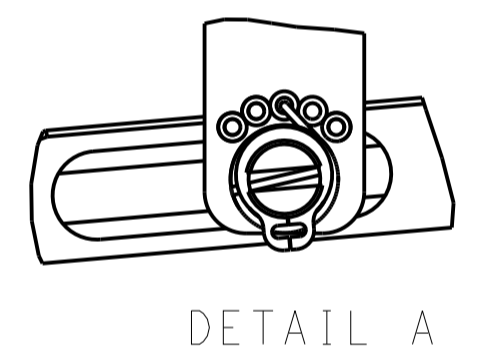

CAM POSITIONS

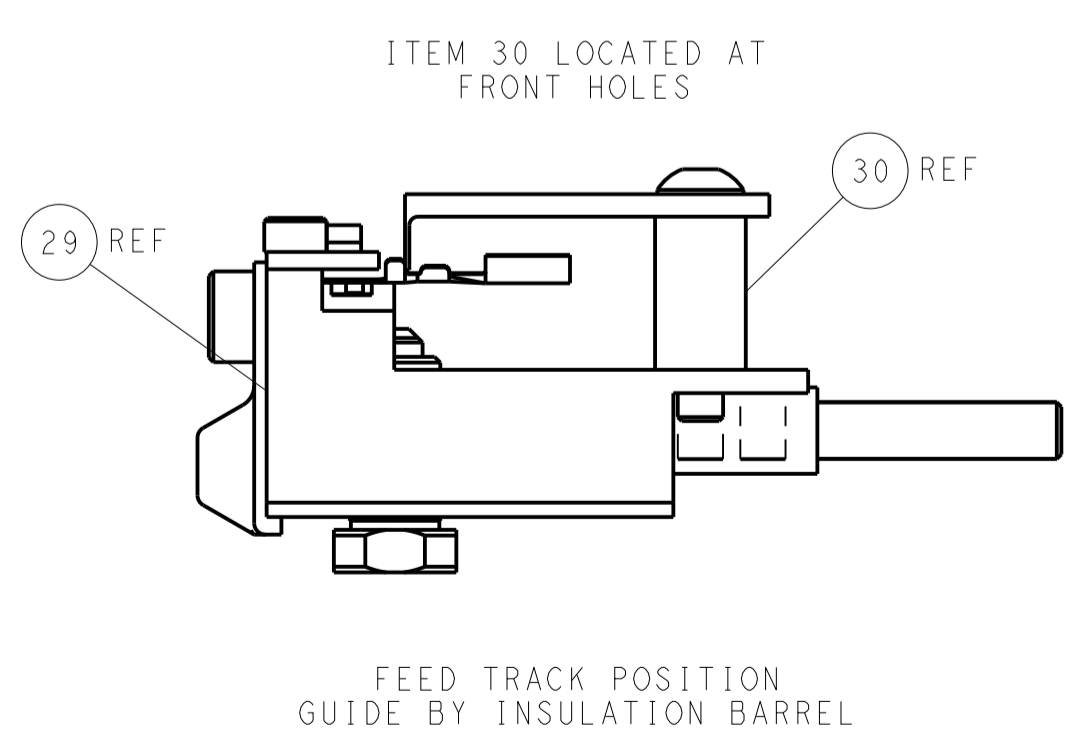
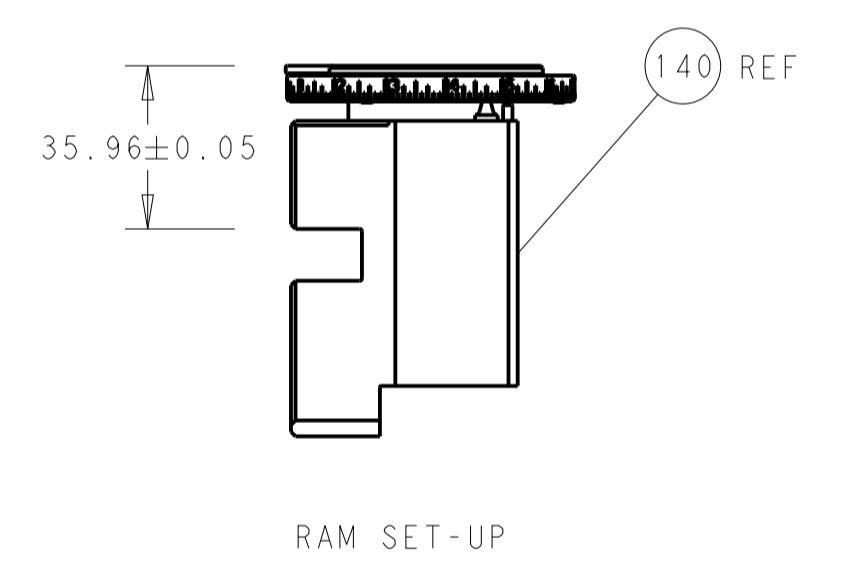
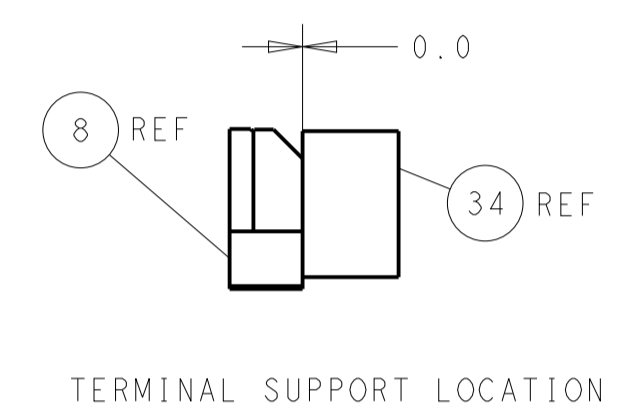
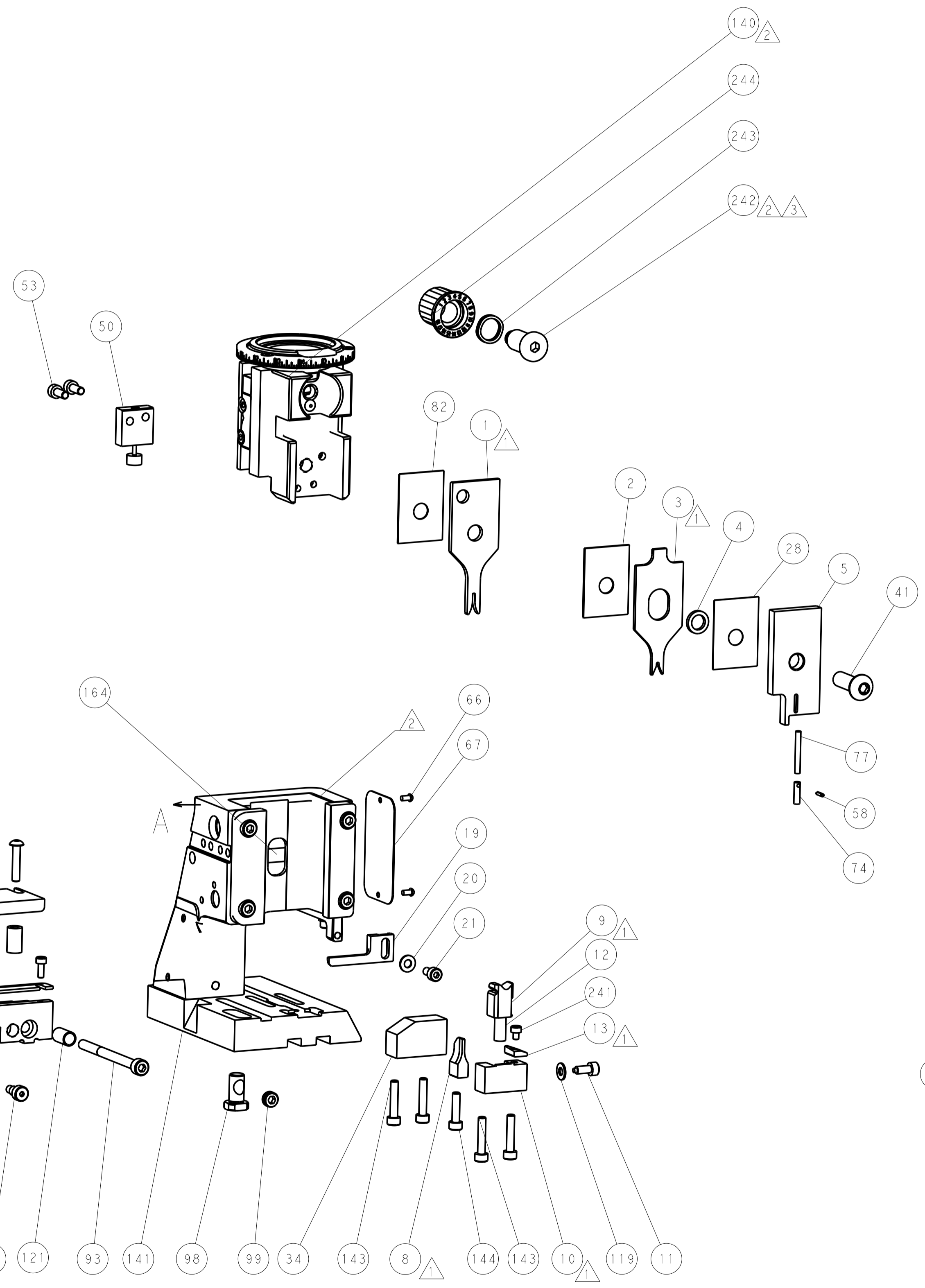
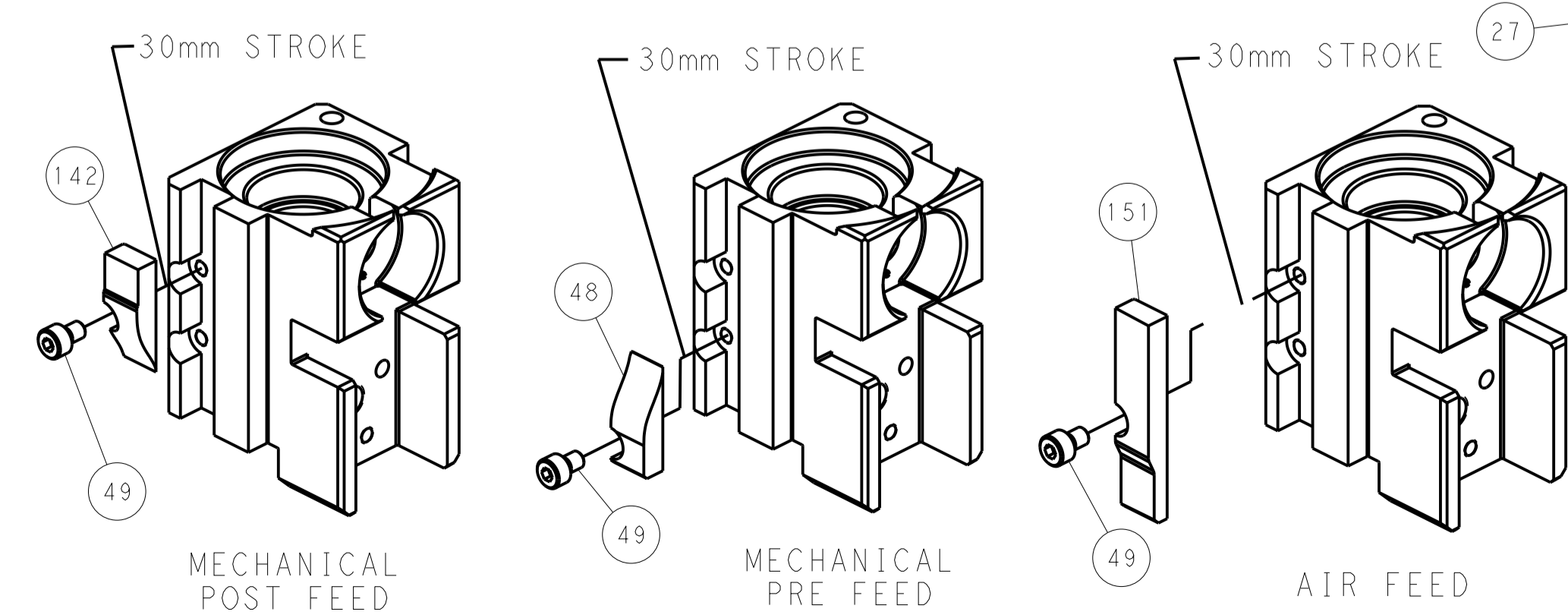

PACIFIC VERSION
 Shown on sheets 3 of 4 & 4 of 4
 (Atlantic version shown on sheets 1 of 4 & 2 of 4)

DIMENSIONS:		TOLERANCES UNLESS OTHERWISE SPECIFIED:		DWN H. HUANG 01JAN2012		TE Connectivity Harrisburg, PA 17105-3608	
mm	0 PLC	±		CHK L. ZHANG 01JAN2012	NAME	Ocean Side Feed Applicator	
	1 PLC	±		APVD H. GUO 01JAN2012	PRODUCT SPEC	-	
	2 PLC	±			APPLICATION SPEC	-	
	3 PLC	±			SIZE	CAGE CODE	DRAWING NO
	4 PLC	±			A1	00779	2151517
	ANGLES	±			WEIGHT	-	
MATERIAL	FINISH				Customer Accessible Production Drawing	SCALE	1:2 SHEET 4 OF 4 REV C1