

DESCRIPTION: FEMALE - SOLDER CUP / MACHINED - ECONOMY

WILL ACCEPT 26-20 AWG WIRE

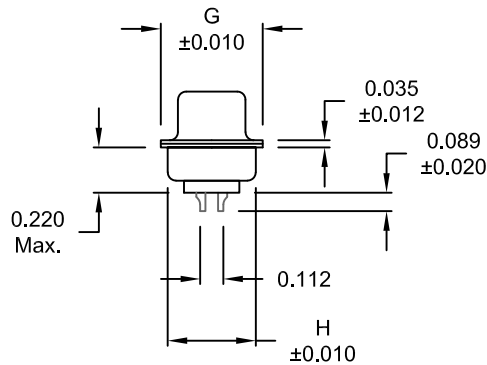
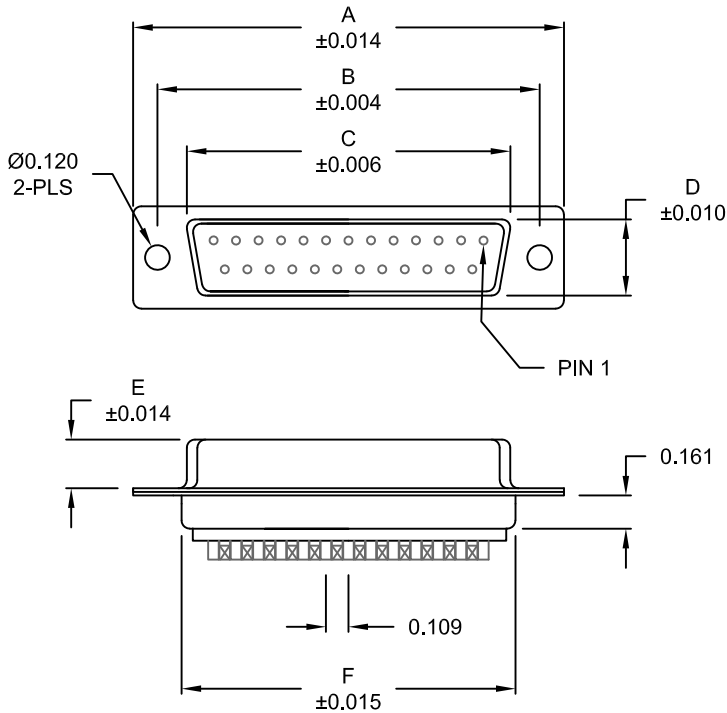

No. OF PINS	DIMENSIONS							
	A	B	C	D	E	F	G	H
9	1.213	0.984	0.642	0.311	0.236	0.756	0.496	0.427
	30.80	24.99	16.30	7.90	5.99	19.20	12.60	10.85
15	1.541	1.312	0.970	0.311	0.236	1.091	0.496	0.427
	39.15	33.32	24.65	7.90	5.99	27.70	12.60	10.85
25	2.087	1.852	1.512	0.311	0.236	1.618	0.496	0.427
	53.00	47.04	38.40	7.90	5.99	41.10	12.60	10.85
37	2.728	2.500	2.157	0.311	0.236	2.256	0.496	0.427
	69.30	63.50	54.80	7.90	5.99	57.30	12.60	10.85
50	2.638	2.406	2.055	0.429	0.240	2.169	0.602	0.527
	67.00	61.11	52.20	10.90	6.10	55.10	15.30	13.39

172-EYY-20YRYY1

- SERIES \_\_\_\_\_  
 POSITIONS \_\_\_\_\_  
 E09  
 E15  
 E25  
 E37  
 E50  
 GENDER \_\_\_\_\_  
 2 = FEMALE  
 TERMINATION \_\_\_\_\_  
 0 = SOLDER CUP  
 SHELL PLATING \_\_\_\_\_  
 2 = TIN  
 3 = NICKEL  
 RoHS COMPLIANT \_\_\_\_\_  
 HARDWARE OPTIONS \_\_\_\_\_  
 00 = NO HARDWARE  
 01 = .098" CLINCH NUT (BOARD SIDE)  
 02 = .236" CLINCH NUT (BOARD SIDE)  
 03 = .236" CLINCH NUT (MOUNTING SIDE)  
 05 = .237" 4-40 BOARD LOCK  
 91 = .237" 4-40 SPACER/ BOARD LOCK  
 PLATING OPTIONS \_\_\_\_\_  
 1 = GOLD FLASH  
 2 = 30MICRO-INCH GOLD

**MATERIAL:**

SHELL: STEEL, NICKEL OR TIN PLATED  
 INSULATOR: UL 94V-O RATED PA6T  
 PROCESS TEMP.: 260°C  
 CONTACT: BRASS

**ELECTRICAL:**

CURRENT RATING: 5 AMPS  
 CONTACT RESISTANCE: 15 mOhms Max.  
 INSULATION RESISTANCE: 1,000 MOhms min.  
 VOLTAGE: 500VAC FOR 1 MINUTE  
 TEMPERATURE: -50° C TO 100° C

DO NOT SCALE FROM DRAWING



THESE DRAWINGS AND SPECIFICATIONS ARE THE PROPERTY OF NorComp AND SHALL NOT BE REPRODUCED, COPIED OR USED AS THE BASIS FOR THE MANUFACTURE OF SALE OF APPARATUS WITHOUT WRITTEN PERMISSION.

DRAWN: PAM JENKINS		DATE: 11-28-05	
SCALE: NTS	SHEET 1	OF 2	REV 11
DWG NO. 172-EYY-20YRYY1			

RoHS COMPLIANT

NorComp

DESCRIPTION: CLINCH NUT HARDWARE

TOLERANCE:  
ALL DIMENSIONS ARE  $\pm 0.010$

ALL CLINCH-NUTS ARE 4-40 INTERNAL THREADS

01X ..... 0.098" (BOARD SIDE) - CN1

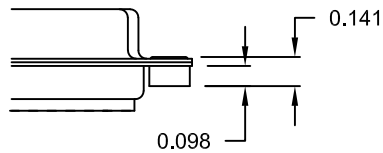

02X ..... 0.236" (BOARD SIDE) - CN2

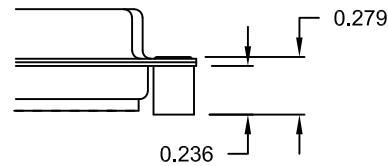

03X..... 0.236" (MATING SIDE) - CN8

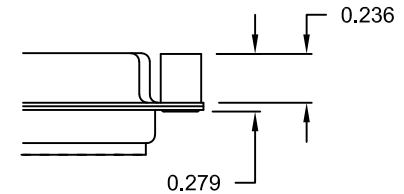

05X ..... 0.237" (BOARD SIDE) - CN10

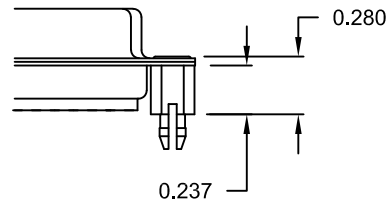

91X ..... 0.237" BOARD SIDE  
0.197 MATING SIDE  
CN10/SFSO4404

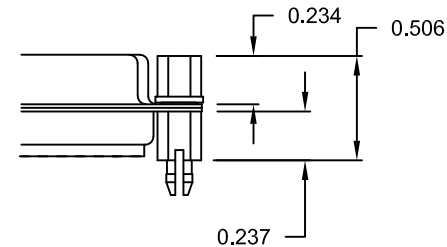

NOTE: 4-40 FEMALE SCREW LOCK IS REMOVABLE

DO NOT SCALE FROM DRAWING

RoHS COMPLIANT



THESE DRAWINGS AND SPECIFICATIONS ARE THE PROPERTY OF NorComp AND SHALL NOT BE REPRODUCED, COPIED OR USED AS THE BASIS FOR THE MANUFACTURE OF SALE OF APPARATUS WITHOUT WRITTEN PERMISSION.

DRAWN:  
PAM JENKINS

DATE:  
11-28-05

NorComp

SCALE: NTS SHEET 2 OF 2 REV 11

DWG NO. 172-EYY-20YRY1