

QUICK START GUIDE FOR DEMONSTRATION CIRCUIT 1904 UNIVERSAL DUAL-BATTERY CHARGER/SELECTOR

LTC1960

DESCRIPTION

Demonstration circuit 1904 is a dual battery PowerPath™ and charger controller featuring the LTC1960. The input voltage is 15V to 20V. The charger output voltage is programmed via SPI serial interface. The maximum charge current is 4A. The demo board has been optimized to work with 3- and 4-cell Li-ion batteries. A jumper is provided to select the LowBatt voltage trip point. The board will not charge any battery without a device to program it. By default the board powers up in 3-Diode mode, which simply means all three power paths to the output (load) are on.

PowerPath selection is programmed over the SPI interface.

This is not a stand-alone demonstration circuit—an SPI interface and associated software is required for proper evaluation. Linear Technology offers demonstration circuit 1223A-B, which includes an SPI-to-USB-port adapter and software to control demonstration circuit 1904.

Design files for this circuit board are available. Call the LTC factory.

LTC is a registered trademark of Linear Technology Corporation.

Table 1. Performance Summary

PARAMETER	CONDITION	VALUE
Maximum Input Voltage	Limited by input Capacitor Volt Ratings	20V ± 10 %
Recommended Minimum Input Voltage		15V ± 10 %
Low Battery Voltage trip point at full discharge	0% capacity voltage. Set by DCLOW TRIP Jumper	>7.9 for 3 cell Li-ion >11V for 4 cell Li-ion
Input Trip Voltage	Set by DCDIV divider network.	13V ± 3%
Maximum Charge Current	V _{in} > V _{BATmax} > 6V	4A ± 5% Settable to 1, 2 and 3 amps.
Short Circuit Shutdown Trip Current	Static Load T > 15ms	8.33A ± 5%
Input Current Limit	IBAT + ILOAD	3.57A ± 5%

QUICK START PROCEDURE

Demonstration circuit 1904 is easy to set up to evaluate the performance of the LTC1960. Refer to Figure 1 for proper measurement equipment setup and follow the procedure below:

1. Connect the input power source to DCIN terminals J1 or TP1 and TP3 using a power supply capable of handling 4A of current within a 15V to 20V range.
2. Connect the load to DCOUT terminals TP2 and TP4.
3. Turn on the input power supply.
4. Attach one or two batteries to the BATTERY 1 or BATTERY 2 terminals or both. Industry standard 5-pin AMP Smart Battery connectors are provided as well as test points for hardwire.

NOTE: The input supply *must* be greater than the full voltage value of the battery to allow a full charge to take place.

5. Program the LTC1960.

NOTE: OPTIONALLY use the DC1223A-B demonstration software to control and configure DC1904.

QUICK START GUIDE FOR DEMONSTRATION CIRCUIT 1904

UNIVERSAL DUAL-BATTERY CHARGER/SELECTOR

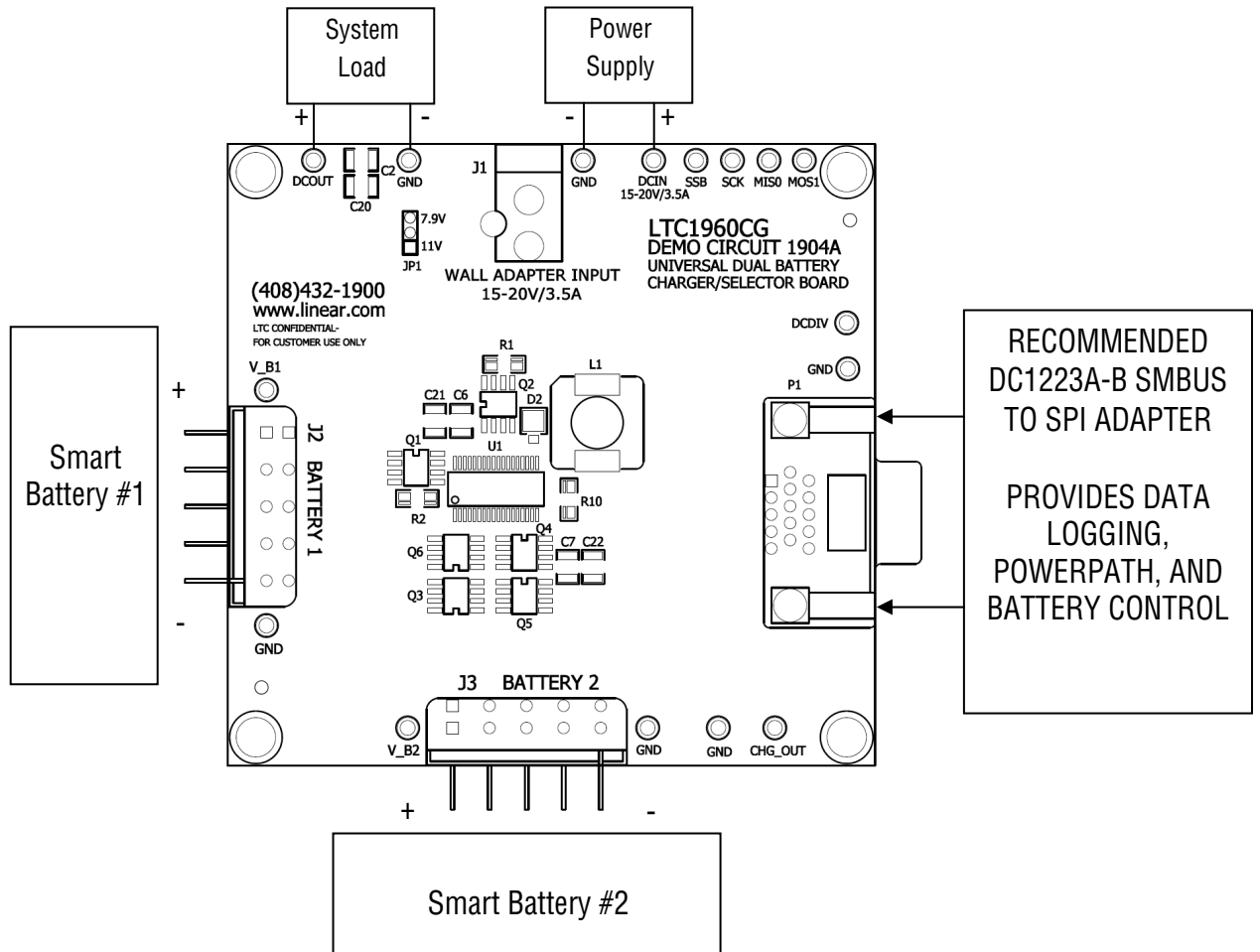
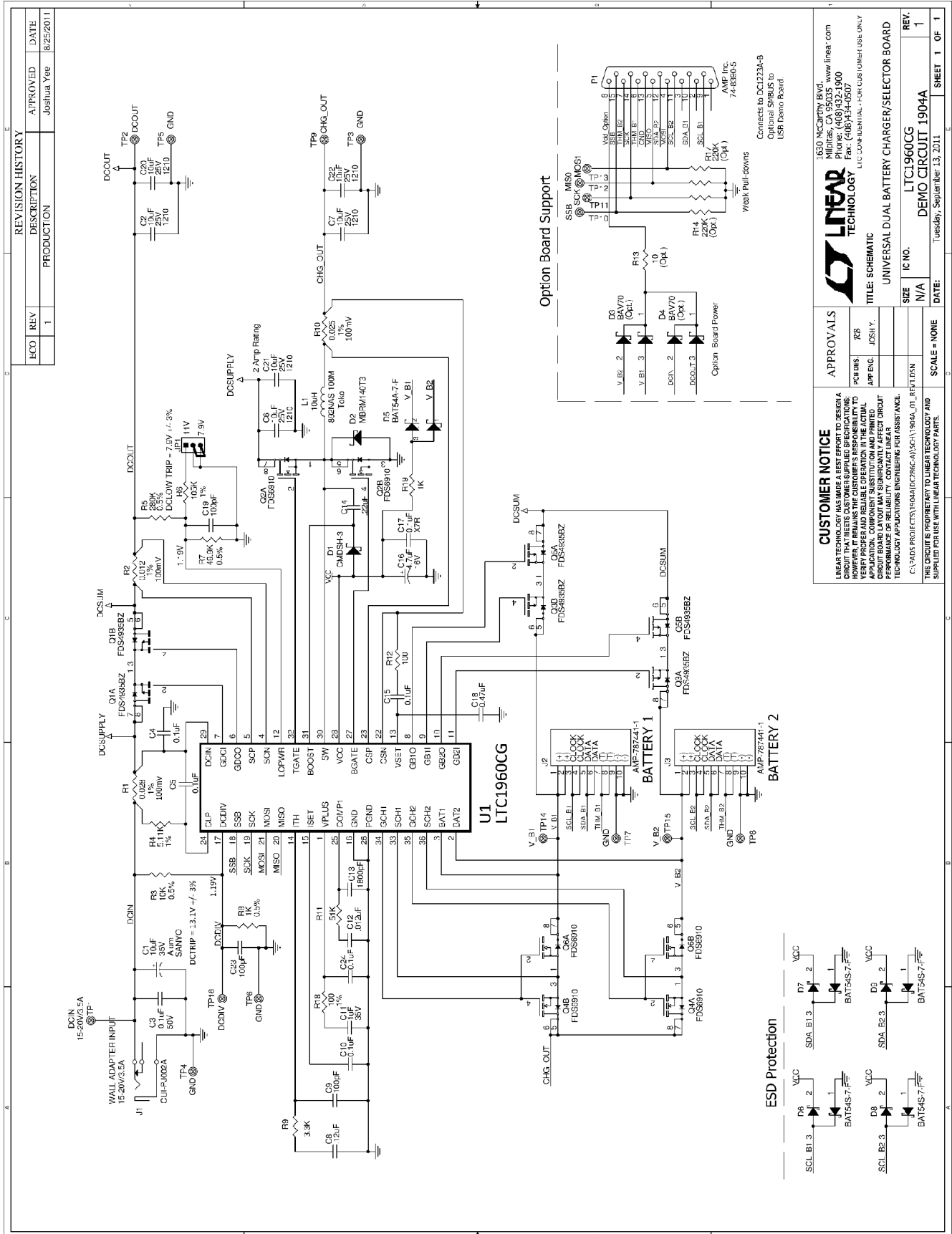

Figure 1: Proper Measurement Equipment Setup

QUICK START GUIDE FOR DEMONSTRATION CIRCUIT 1904 UNIVERSAL DUAL-BATTERY CHARGER/SELECTOR



REVISION HISTORY		APPROVED	DATE
ECO	REV 1	Joshua Yee	8/25/2011
DESCRIPTION			
PRODUCTION			

CUSTOMER NOTICE
LINEAR TECHNOLOGY HAS MADE A BEST EFFORT TO DESIGN A CIRCUIT THAT MEETS CUSTOMER-SPECIFIED SPECIFICATIONS; HOWEVER, THE USER ASSUMES ALL RISK OF INJURY, DAMAGE TO PROPERTY, OR OTHER LIABILITY ARISING FROM THE APPLICATION. COMPONENT SUBSTITUTION AND PRINTED CIRCUIT BOARD LAYOUT MAY SIGNIFICANTLY AFFECT CIRCUIT PERFORMANCE. LINEAR TECHNOLOGY ASSUMES NO LIABILITY FOR TECHNOLOGY APPLICATIONS ENGINEERING ASSISTANCE.

CU-3405-PROJECTS-1904A(DC232A-B) (REV. 01) (REV. 01)

APPROVALS

FCB DES.	JZB
APP ENG.	JDSH Y.

SCALE - NONE

IC NO. LTC1960CG

REV. 1

DATE: Tuesday, September 13, 2011

SHEET 1 OF 1

