

MATERIAL NUMBER	ENGINEERING NUMBER	WIRE RANGE AWC	MM <sup>2</sup>	FITS MALE PLUG DIA.	"L" MAX.	I.D. MIN.	"D" ±.01	H ±.01	"E" NOM.
190370002	AA-1121	22-18	0.25-1.3	.156/(3.96)	.63/(16.0)	.066/(1.68)	.125/(3.18)	.19/(4.8)	.31/(7.88)
190370015	AA-1120	22-18	0.25-1.3	.180/(4.57)	.69/(17.53)	.066/(1.68)	.210/(5.33)	.21/(5.3)	.37/(9.40)
190370004	BB-1122	16-14	1.0-2.6	.156/(3.96)	.63/(16.0)	.089/(2.26)	.125/(3.18)	.19/(4.8)	.31/(7.88)
190370006	BB-1123	16-14	1.0-2.6	.180/(4.57)	.69/(17.53)	.089/(2.26)	.210/(5.33)	.21/(5.3)	.37/(9.40)

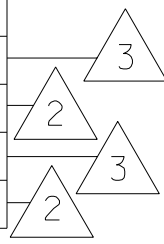

(B)

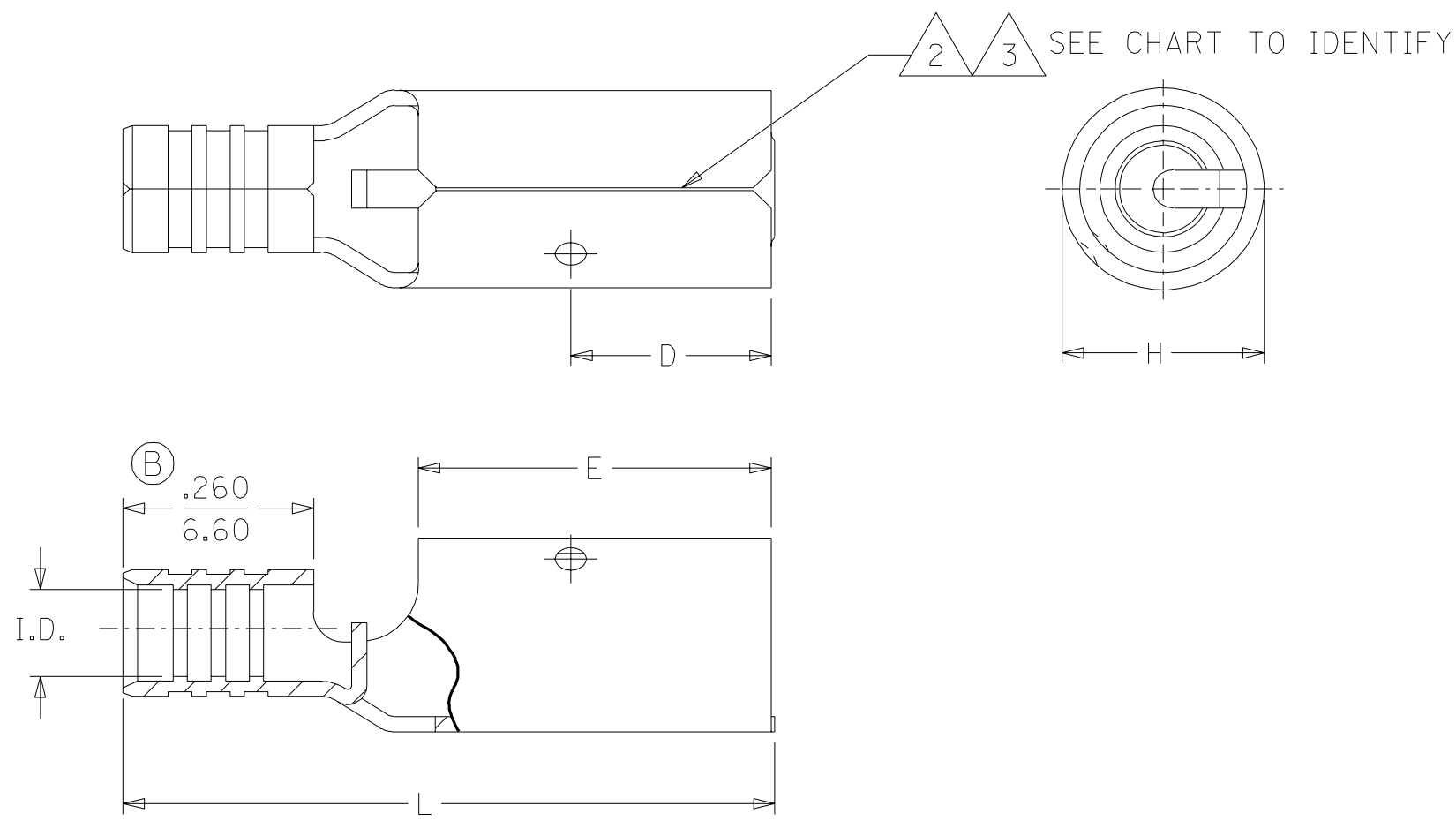

NOTES;  
 (B) 1. MATERIAL: .016/0.41 BRASS  
 FINISH: ELECTRO-TIN PLATING  
 2 SEAM IS FULLY CLOSED.  
 3. SEAM HAS A .010 GAP NOMINAL.

DEL TAPE NO'S	EC NO. ETC2003-0201	DRWN: BRE 03/05/08	CH'K: HEB 03/05/08	APPR: RWD 03/05/08
B	REV	DESCRIPTION	QUALITY SYMBOLS	MAJOR = 0
			CRITICAL = 0	

GENERAL TOLERANCES: (UNLESS SPECIFIED)	
4 PLACES	±0. mm ±. INCH
3 PLACES	±0. mm ±.01 INCH
2 PLACES	±0.3 mm ±.01 INCH
1 PLACE	±0. mm ±. INCH
ANGULAR: ±1/2 °	
DRAFT WHERE APPLICABLE MUST REMAIN WITHIN DIMENSIONS	

SCALE NO: NE	DESIGN UNITS
BRE 02/08/12	<input type="checkbox"/> mm <input checked="" type="checkbox"/> INCH
CHECKED BY & DATE	HEB 02/08/12
APPROVED BY & DATE	RWD 02/08/12
CAD FILENAME	SD-19037-002 .DGN

THIRD ANGLE PROJECTION		DIMENSIONS:		SHT	REV
<input type="checkbox"/> mm <input checked="" type="checkbox"/> INCH		<input type="checkbox"/> mm <input type="checkbox"/> INCH			
DRAWN BY & DATE		TITLE: KRIMPTITE FEMALE BULLET RECEPTACLE			
MATERIAL NO.		DRAWING NO.		SHEET NO.	
SEE CHART		SD-19037-002		1 OF 1	
THIS DRAWING CONTAINS INFORMATION THAT IS PROPRIETARY TO MOLEX INCORPORATED AND SHOULD NOT BE USED WITHOUT WRITTEN PERMISSION.					SIZE B