

# Customer Information Sheet

DRAWING No.: G125-304XX96L4

IF IN DOUBT - ASK

©

NOT TO SCALE

THIRD ANGLE PROJECTION

ALL DIMENSIONS IN mm

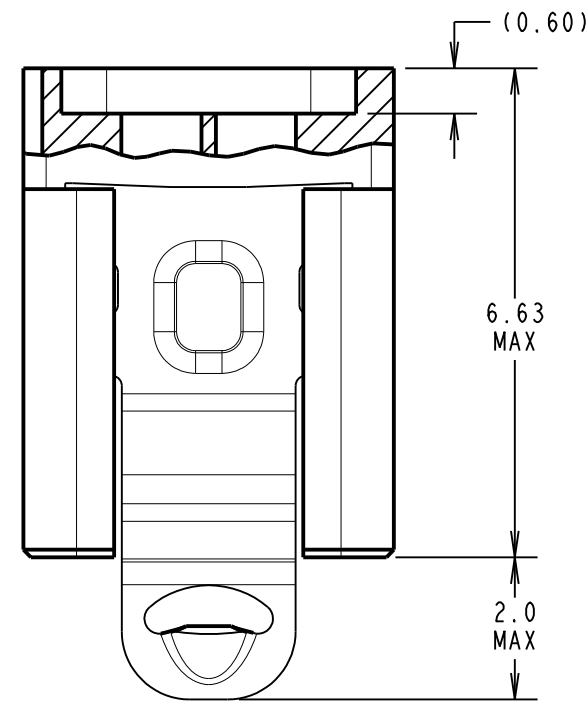
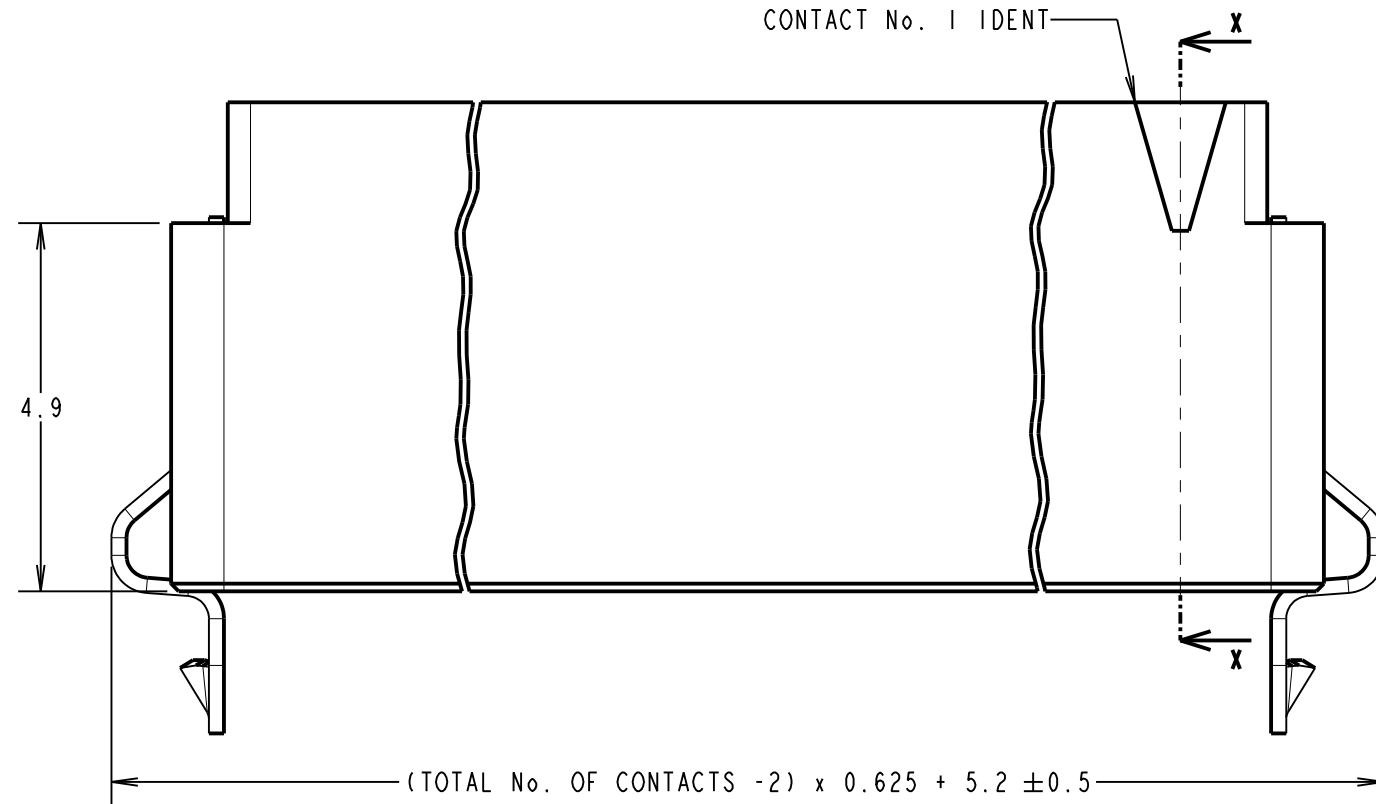

SECTION X-X



PATENTED TECHNOLOGY

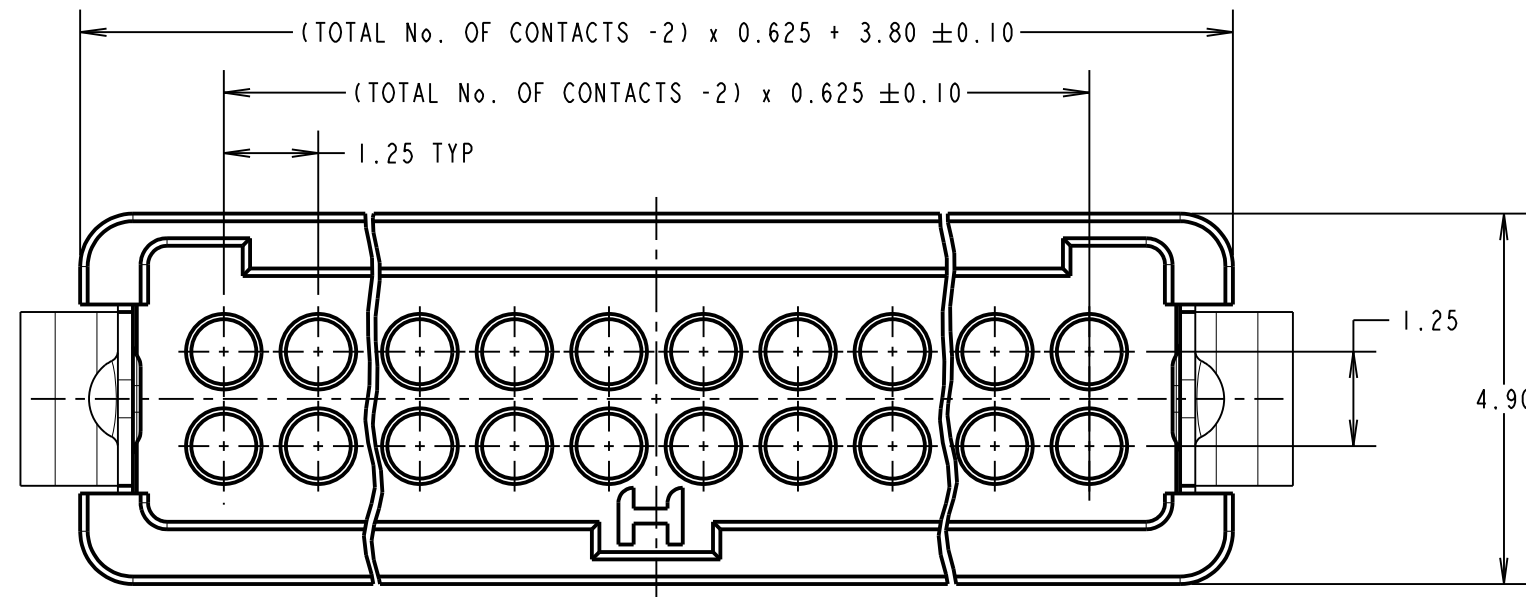

LATCHES (2-OFF)

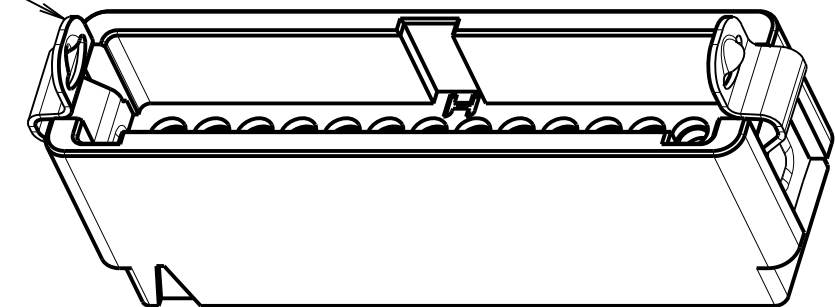

ORDER CODE:  
**G125-304XX96L4**  
 TOTAL No. OF CONTACTS \_\_\_\_\_  
 06, 10, 12, 16, 20, 26, 34, 50.

MGP	1	14.01.19	21736
NAME	ISS.	DATE	C/NOTE
APPROVED: MGP			
CHECKED: SB			
DRAWN: S.BENNETT			
CUSTOMER REF.:			
ASSEMBLY DRG:			

- NOTES:
1. PACK SIZE: 10 PER BAG.
  2. MOULDING TO BE USED WITH G125-1010005 AND G125-1020005 MALE CRIMP CONTACTS.
  3. FOR ASSEMBLY INSTRUCTIONS SEE INSTRUCTION SHEET IS-38.
  4. FOR MATERIAL AND FINISH DETAILS SEE G125 SERIES COMPONENT SPECIFICATION SHEET.

## HARWIN

www.harwin.com  
 technical@harwin.com

THIS DRAWING AND ANY INFORMATION OR DESCRIPTIVE MATTER SET OUT HEREON ARE CONFIDENTIAL AND COPYRIGHT PROPERTY OF THE HARWIN GROUP AND MUST NOT BE DISCLOSED, LOANED, COPIED OR USED FOR MANUFACTURING, TENDERING OR FOR ANY OTHER PURPOSE WITHOUT THEIR WRITTEN PERMISSION.

TOLERANCES  
 X. = ±1mm  
 X.X = ±0.50mm  
 X.XX = ±0.10mm  
 X.XXX = ±0.01mm  
 ANGLES = ±5°  
 UNLESS STATED

MATERIAL:  
 SEE NOTE 4  
 FINISH: SEE NOTE 4  
 S/AREA: mm<sup>2</sup>

TITLE: G125 SERIES MALE CRIMP MOULDING WITH POTTING WALL AND LATCHES ASSEMBLY  
 DRAWING NUMBER:  
**G125-304XX96L4**  
 SHT 2 OF 2

# Customer Information Sheet

DRAWING No.: G125-SERIES COMPONENT SPECIFICATION

IF IN DOUBT - ASK

©

NOT TO SCALE

THIRD ANGLE PROJECTION

ALL DIMENSIONS IN mm

**SPECIFICATIONS:**

**MATERIALS:**

MOULDING, PICK & PLACE CAP:  
POLYAMIDE, PA4T-GF30 FR(40) UL94V-0,  
HALOGEN FREE, FREE OF RED PHOSPHORUS

**CONTACTS:**

MALE PC-TAIL/SMT = PHOSPHOR BRONZE  
MALE CRIMP = BRASS  
ALL FEMALE CONTACTS = COPPER ALLOY

**LOCKING HARDWARE:**

LATCHES: COPPER NICKEL TIN ALLOY  
SCREW LOCK: STAINLESS STEEL

BACK POTTING COMPOUND (CABLE ASSEMBLIES ONLY):  
STYCAST 2651 MM BACK POTTING WITH CATALYST 9

**FINISH:**

ALL CONTACTS:  
0.2-0.3µ GOLD OVER NICKEL  
LATCHES:  
3.0µ 100% TIN OVER NICKEL

**MECHANICAL:**

DURABILITY = 1000 OPERATIONS  
INSERTION FORCE = 2.8N MAX  
WITHDRAWAL FORCE = 0.2N MIN

**ENVIRONMENTAL:**

CLASSIFICATION: 65/150/56 DAYS AT 93% RH

**TEMPERATURE RANGE:**

EIA-364-32 : 2000 TEST CONDITION IV, DWELL  
30mins, 5 CYCLES -65°C TO +150°C

\* EIA-364-28D : 1999: TEST CONDITION IV: VIBRATION SEVERITY:  
10Hz TO 2000Hz, 1.5MM, 198 mm/s<sup>2</sup> (20G). DURATION 2Hr

\* EIA-364-27B : 1996: TEST CONDITION E SHOCK SEVERITY: 981 mm/s<sup>2</sup>  
(100G) FOR 6ms IN Z AXIS, 490 mm/s<sup>2</sup> (50G) FOR 11ms IN X & Y AXIS.

\* EIA-364-01A : 2000: ACCELERATION: 490 mm/s<sup>2</sup> (50G)  
\* BUMP SEVERITY: 390 mm/s<sup>2</sup> (40G), 4000± 10 BUMPS  
\* TESTED WITH LATCHED CONNECTORS

**ELECTRICAL:**

**CURRENT RATING:**

EIA-364-70A : 1998: INDIVIDUAL CONTACT IN ISOLATION AT 25°C = 2.8A MAX  
EIA-364-70A : 1998: ALL CONTACTS SIMULTANEOUSLY AT 25°C = 2.0A MAX

**CONTACT RESISTANCE:**

EIA-364-06C : 2006: INITIAL CONTACT RESISTANCE = 20mΩ MAX  
EIA-364-06C : 2006: CONTACT RESISTANCE AFTER CONDITIONING = 25mΩ MAX

**WORKING VOLTAGE:**

EIA-364-20C : 2004: SEA LEVEL (1006mbar) = 450V DC/AC PEAK  
EIA-364-20C : 2004: ALTITUDE LEVEL (44mbar) = 250V DC/AC PEAK

VOLTAGE PROOF AT SEA LEVEL (1013mbar) = 600V DC/AC PEAK

**INSULATION RESISTANCE:**

EIA-364-21C : 2000: INSULATION RESISTANCE (INITIAL)  
= 10 GΩ MIN AT 500V DC  
EIA-364-21C : 2000: INSULATION RESISTANCE (AFTER CONDITIONING)  
= >1 GΩ MIN AT 500V DC

FOR FULL COMPONENT SPECIFICATION SEE C125XX (LATEST ISSUE).

PATENT PENDING  
UK 1205109.0



MGP	4	22.06.17	20668
NAME	ISS.	DATE	C/NOTE
APPROVED: MGP			
CHECKED: SB			
DRAWN:		S.FLOWER	
CUSTOMER REF.:			
ASSEMBLY DRG:			

**HARWIN**

www.harwin.com  
technical@harwin.com

THIS DRAWING AND ANY  
INFORMATION OR DESCRIPTIVE  
MATTER SET OUT HEREON ARE  
CONFIDENTIAL AND COPYRIGHT  
PROPERTY OF THE HARWIN  
GROUP AND MUST NOT BE  
DISCLOSED, LOANED, COPIED  
OR USED FOR MANUFACTURING,  
TENDERING OR FOR ANY  
OTHER PURPOSE WITHOUT  
THEIR WRITTEN PERMISSION.

**TOLERANCES**  
X = ±1mm  
X.X = ±0.50mm  
X.XX = ±0.10mm  
X.XXX = ±0.01mm  
ANGLES = ±5°  
UNLESS STATED

**MATERIAL:**

SEE ABOVE

**FINISH:**

SEE ABOVE

**S/AREA:**

mm<sup>2</sup>

**TITLE:**

G125 SERIES COMPONENT SPECIFICATION

**DRAWING NUMBER:**

G125-SERIES CONNECTORS

SHT  
1 OF 1