

Air Feed Kit 1752470-1
(Shown with the terminator base access panel removed)

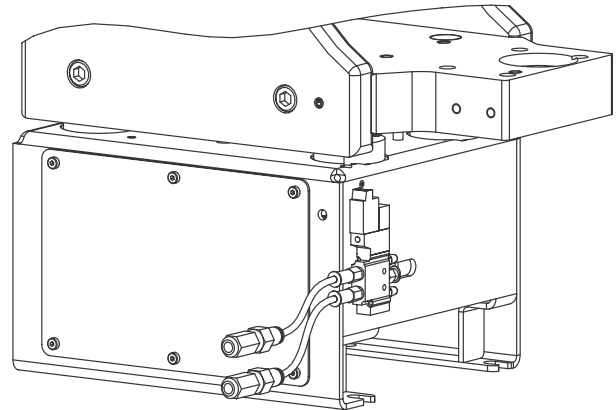

Quick Disconnect Kit 1752471-1

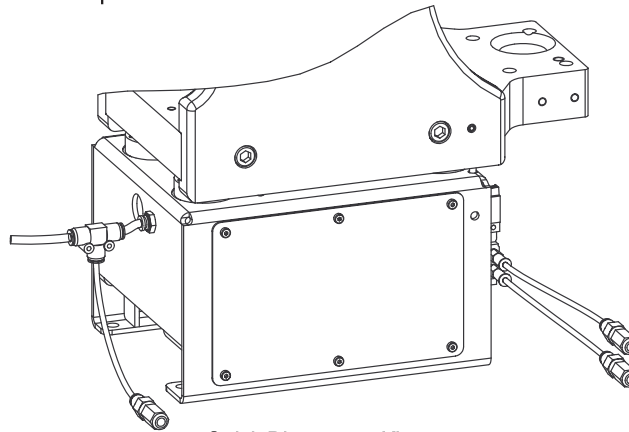

Quick Disconnect Kit 1752471-2

Figure 1

1. INTRODUCTION

Air Feed Kit 1752470-1 along with the optional Quick Disconnect Kits 1752471-1 and 1752471-2 (shown in Figure 1) are used to activate air feed applicators of various feed styles.

These kits were designed for use with the AMPOMATOR System III Lead-Making Machine and the AMP-O-LECTRIC Servo Terminator III Machine.

2. DESCRIPTION

Air Feed Kit 1752470-1 consists of an electronically controlled valve assembly, along with the required fittings and pneumatic tubing to properly connect the valve. The optional quick-disconnect kits (Figure 1) may be added to allow easy exchange of air-feed applicators mating quick-connect fittings in a production environment.



The air feed kit is controlled by automatic electronics and could activate with out notice. Use caution when handling applicators connected to the air feed kit or through the quick-disconnect kits.



Personal injury could result if the air feed kit or quick-disconnect kits are used without protective guards in place.

3. INSTALLATION

3.1. Air Feed Kit Installation

1. Start the installation of the air feed kit by first removing the access cover on the terminator base.

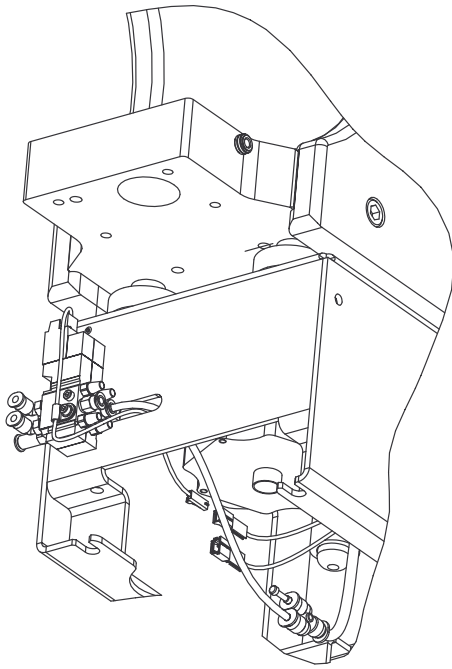

Figure 2

2. Feed both the pneumatic tubing and the control line through the slot in the front wall of the base. (Refer to Figure 2.)
3. Remove a blanking plug from one branch of the quick release "Y" connector.
4. Using the provided pneumatic tubing, make the required connection to the "Y" connector.
5. Connect the control connector to the 2 position connector in the terminator base.
6. Use the provided hardware to mount the valve to the terminator base (Figure 3).

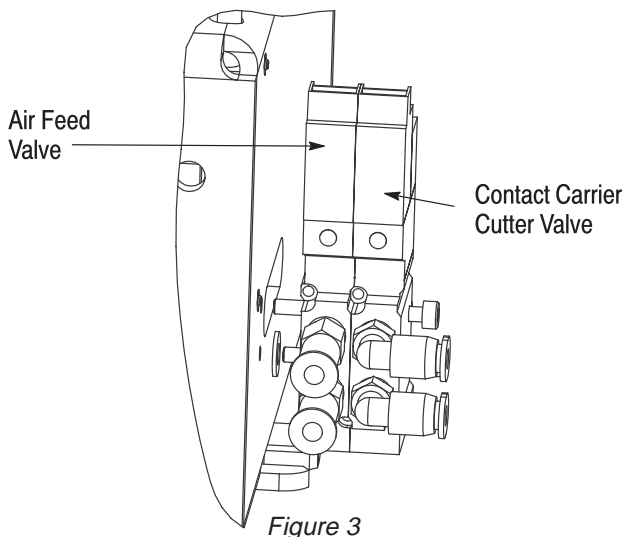

Figure 3

Be sure to position the provided washer behind the valve on the lower screw. (See Figure 3) and secure the control line in the provided "P-clip."

NOTE

If the optional contact carrier cutter valve is also installed, position the air feed valve underneath as shown in Figure 3.

3.2. Quick-Disconnect Kit Installation

Optional Quick-Disconnect Kit 1752471-1 easily installs by pushing the provided pneumatic tubes into the fittings on the actuating valve. See Figure 4.

To install the 1752471-2 kit, repeat the procedure for the -1 assembly. In addition, add the "T" fitting and quick disconnect extension as shown in Figure 5.

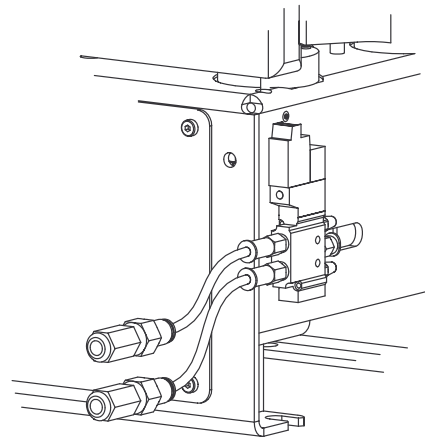

Figure 4

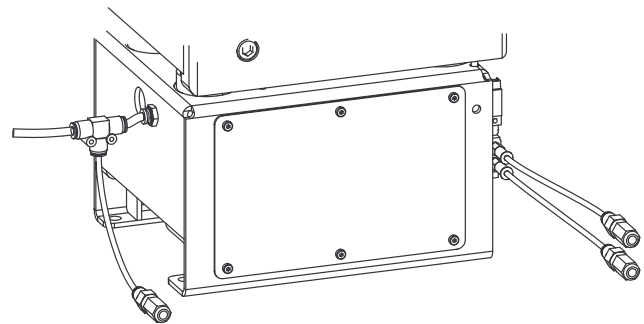
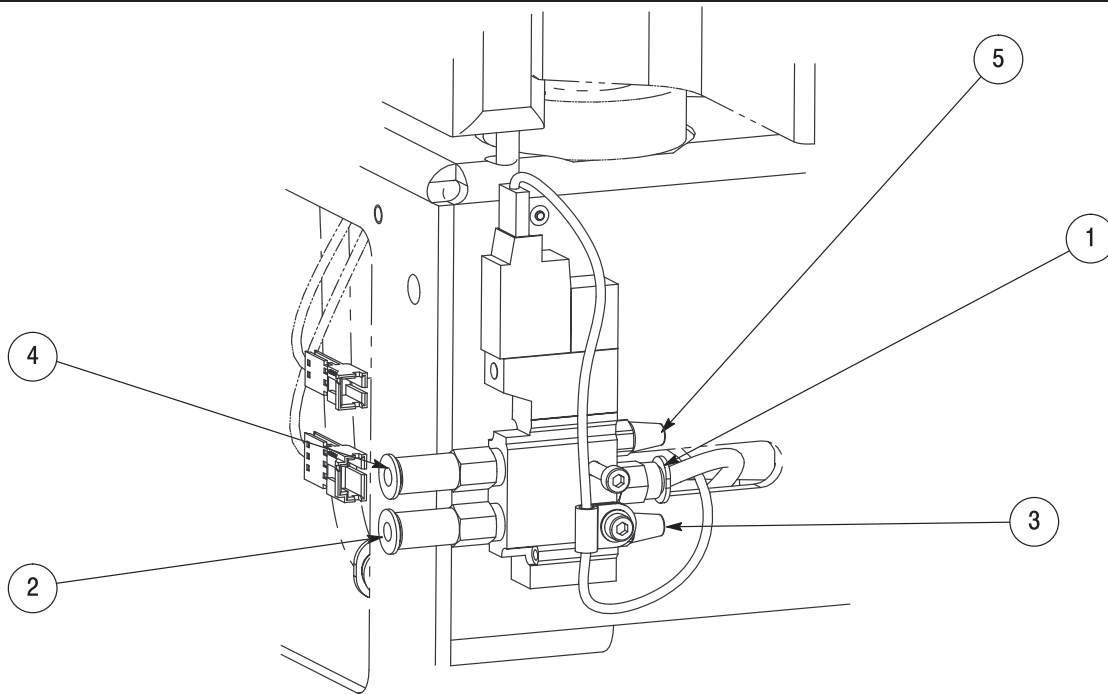

Figure 5

4. OPERATION

4.1. Valve Port Identification



PORT NUMBER	DESCRIPTION	SINGLE-ACTING, SPRING RETURN	DOUBLE ACTING APPLICATIONS
1	Main Air Input	--	--
2	Normally Pressurized	Feed Forward	Feed Forward
3	Exhaust	--	--
4	Normally Un-pasteurized	Not Used	Retract
5	Exhaust	--	--
T-Fitting	Constant Air	Special Applications	

Figure 6

4.2. Software

In order to use the air feed kit, the software required for it's operation must first be installed on each terminator. This is done by selecting the ST icon (see Figure 7) located on the main screen in TopWin.

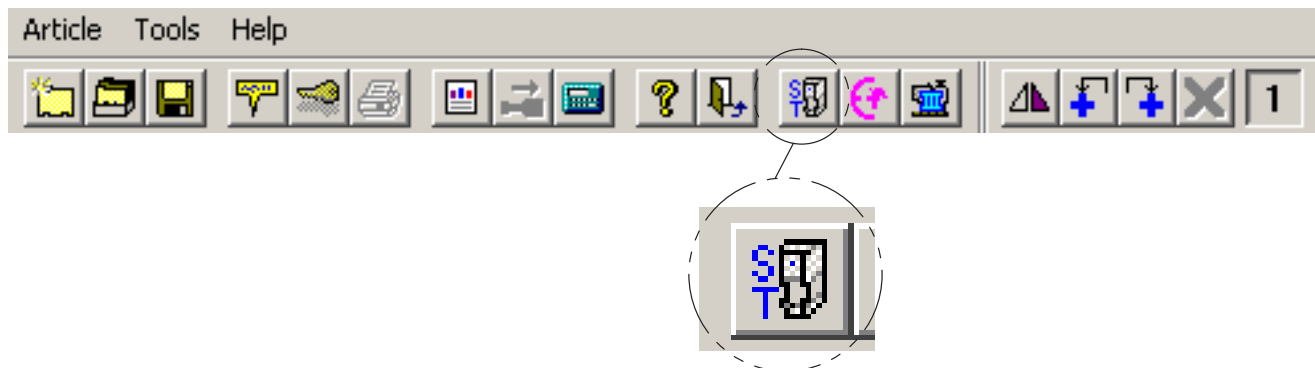

Figure 7

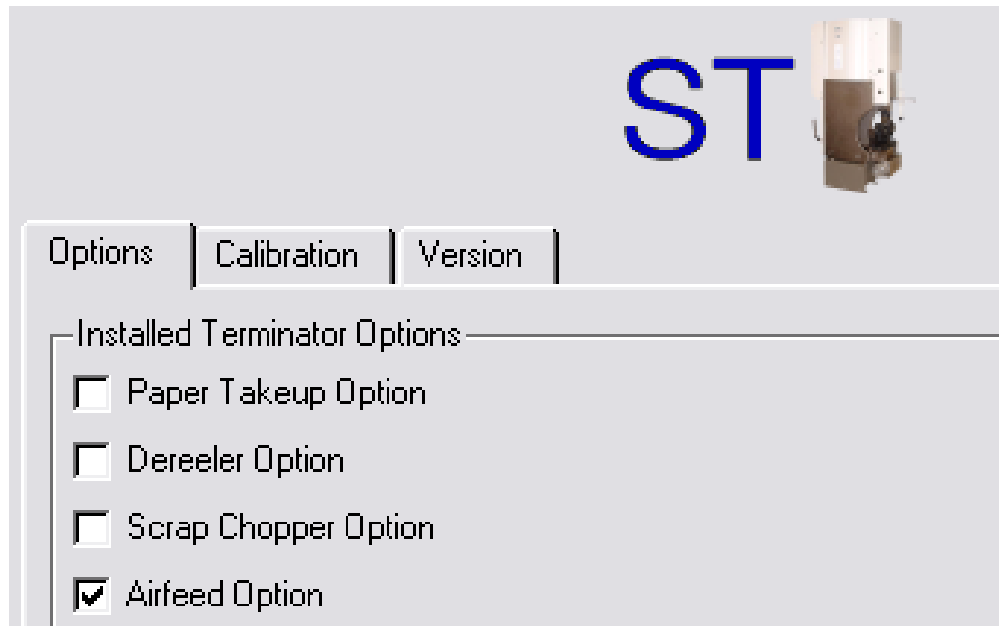

Figure 8

The control of the air feed valve is terminal specific. To turn on and setup the activation of the air feed valve select the Terminator icon on the “Process” tab in the terminal specific settings window (See Figure 9).

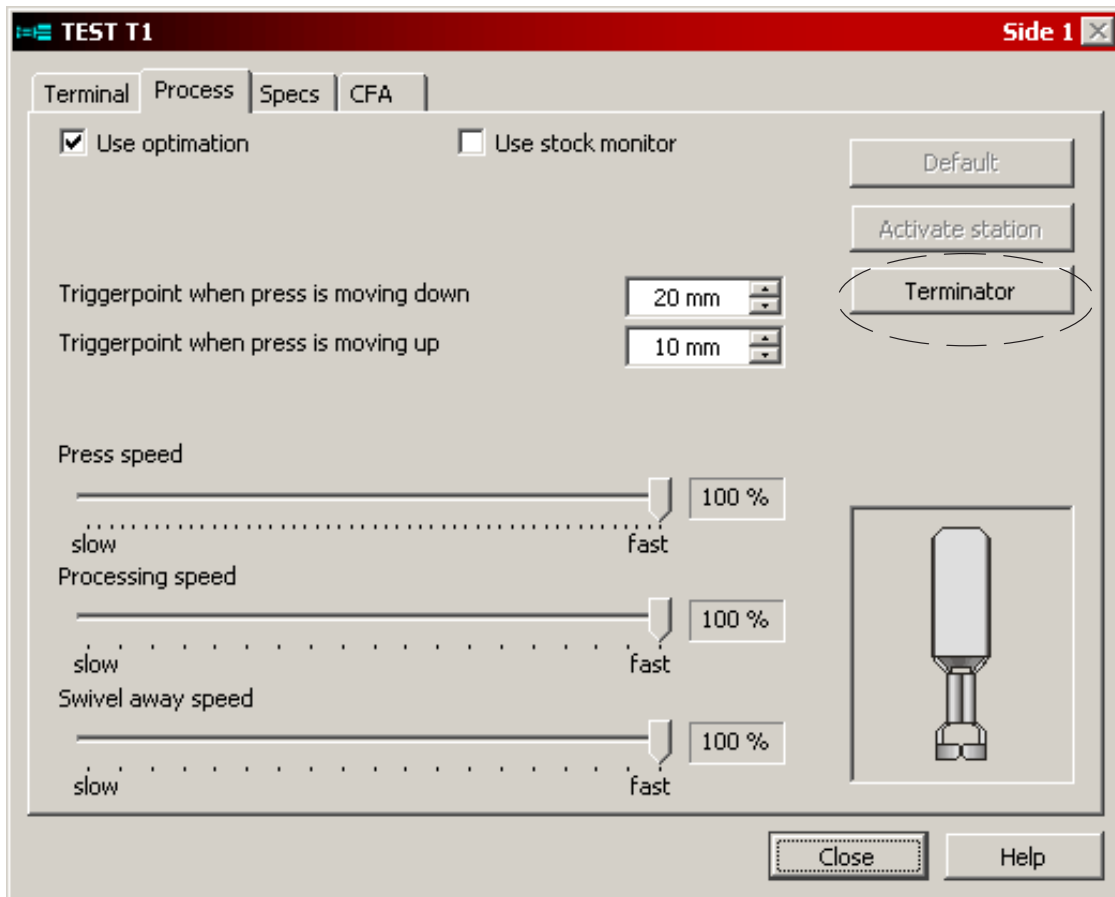

Figure 9

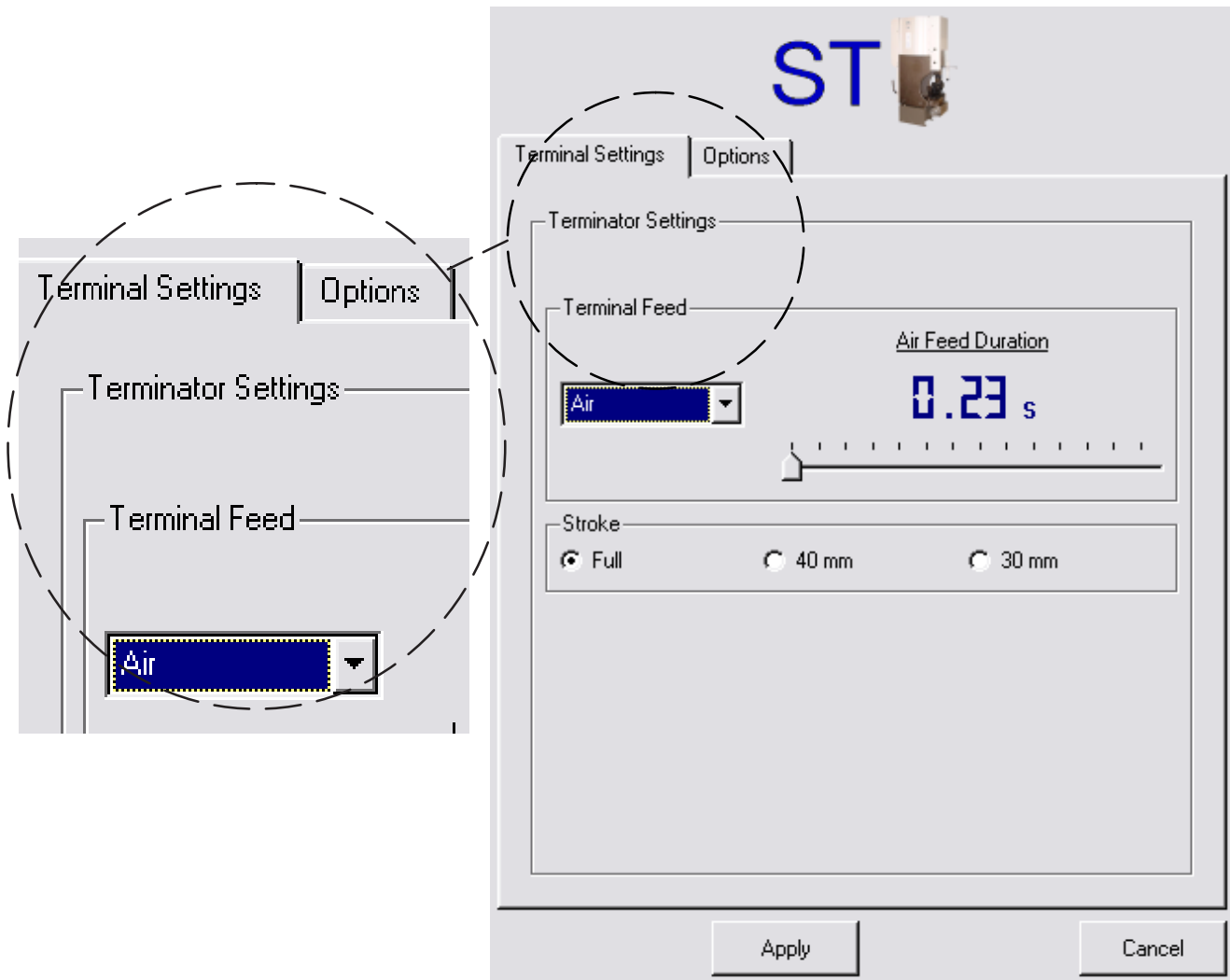

Figure 10

Under the “Terminal Settings” tab of the ST Setup window, select the terminal feed. Once “Air” is selected, the “Air Feed Duration” can be set. See Figure 10.

5. REPLACEMENT

NOTE

It is recommended that these kits be ordered in their entirety for spare or replacement situations.



6. TROUBLESHOOTING

PROBLEM	PROBABLE CAUSE	REMEDY
Air valve not activating	Air feed not installed in the software	Install software.
		Verify operation by pressing the manual override button on the valve.
	Terminal feed set to "Mechanical" in software	Change feed to "Air" in the software.
		Verify operation by pressing the manual override button on the valve.
	Bad electrical connection	Verify that the light on the valve lights when the valve is fired
		Measure 24 volt output on the connector on the interconnect pc board. Repeat the step at the valve connector.
Terminal not being fed properly	The air feed duration set too low	Adjust the duration to a longer time period.
	Actuating cylinder is not properly connected	Review the operation section of the manual to determine if the applicator is properly connected.
	Low air pressure	Verify the pressure of the machine
		Be sure the air supply lines are not pinched.
	Bad air connection	Verify that all fittings are properly connected
		Verify that the line check valves are working correctly by replacing the suspect fitting

7. REVISION SUMMARY

- Updated format to current corporate requirements
- Screens and text reference AMPOMATOR System III Leadmaker and AMP-O-ELECTRIC Servo Terminator III Machine