

PART NUMBER	REVISION	DESCRIPTION	FEED TYPE
2150376-2	E	FINE CRIMP HEIGHT ADJUST	PNEUMATIC
7-2150376-2	E	PNEUMATIC AND CRIMP TOOLING KIT	PNEUMATIC
7-2150376-7	C	CRIMP TOOLING KIT	-

ATLANTIC VERSION TERMINATOR INTERFACE ADAPTER

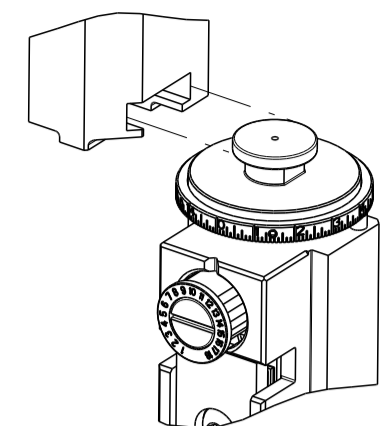

APPLICATOR DATA		
CRIMP	SIZE	TYPE
WIRE	2.28 mm [.090]	F
INSUL	3.00 mm [.118]	F
APPL INSTRUCTIONS 408-35043		

TERMINAL DATA: TE TERMINAL		TE CRIMP SPECIFICATION	
TERMINAL NAME: L.I.F. POSITIVE LOCK CONTACT 5MM SERIES			
WIRE STRIP LENGTH		INSULATION DIAMETER RANGE	
3.50-4.50 mm [.138-.177 IN]		∅ 1.30-2.00 mm [.051-.079 IN]	
TERMINAL APPLICATION SPECIFICATION	114-15008	-	-
TERMINALS APPLIED			
TE TERMINAL	TE TERMINAL	TE TERMINAL	TE TERMINAL
141991-1	141991-3	1-141991-2	142685-3
141991-2	1-141991-1	2-141991-2	

WIRE SIZE	CRIMP HEIGHT mm [INCH]	CRIMP HEIGHT REFERENCE SETTING
0.6+0.35	1.42 +/- 0.05 [.056 +/- .002]	8.5
1.00mm2	1.42 +/- 0.05 [.056 +/- .002]	8.5
0.35+0.35	1.35 +/- 0.05 [.053 +/- .002]	9.4
0.60mm2	1.29 +/- 0.05 [.051 +/- .002]	10.1
0.35mm2	1.19 +/- 0.05 [.047 +/- .002]	11.4

- RECOMMENDED SPARE PARTS
- REFER TO SUPPLIED INSTRUCTION SHEET FOR CLEANING, LUBRICATION AND STORAGE OF APPLICATOR.
- APPLY PART NUMBER 2-23419-6 LOCTITE TO THREADS OF ITEM 242. APPLY PART NUMBER 1-23419-5 LOCTITE TO THREADS OF ITEM 50.
- CRIMP HEIGHT REFERENCE SETTING WAS THE SETTING USED WHEN THE APPLICATOR WAS QUALIFIED AT THE FACTORY. ADJUSTMENT MAY BE NECESSARY WHEN RUNNING APPLICATOR IN THE FIELD.
- TERMINAL LUBRICANT IS RECOMMENDED.
- 6. UNLESS SPECIFIED OTHERWISE TORQUE VALUES SHALL BE USED PER DOCUMENT, 101-35000.
- TERMINAL PITCH NOT COMPATIBLE WITH MECHANICAL FEED.

***WARNING**
ON INSTALLATION, SET WIRE DISC TO CRIMP HEIGHT REFERENCE SETTING FOR LARGEST WIRE SIZE. CRIMP HEIGHT REFERENCE SETTINGS GREATER THAN THE VALUE SHOWN MAY CAUSE DAMAGE TO THE CRIMP TOOLING. REFER TO THE INSTRUCTION SHEET FOR PROPER SETUP AND ADJUSTMENTS.

LOC	DIST	REVISIONS					
A	66	P	LTN	DESCRIPTION	DATE	OWN	APVD
		C		ECR-17-012112	21AUG2017	TB	GB
		C1		ECR-17-013030	05SEP2017	TB	GB
		D		ECR-18-017376	05NOV2018	FZ	CT
		E		ECR-20-001960	11FEB2020	TB	RK

-	1	1	2119641-1	FEED CAM, AIR FEED	248	
-	1	1	2119082-9	CAM, SNAIL, INSULATION ADJUSTMENT	244	
-	1	1	2079764-1	WASHER, WAVE SPRING, CREST-TO-CREST	243	
	1	1	2119083-1	RETAINER, INSULATION DIAL	242	
-	1	1	2844940-4	AIR FEED MODULE	238	
-	1	1	1-18028-0	WASHER, FLAT, REG M8	192	
-	1	1	6-993111-6	PIN, SLOTTED SPRING 3.0 X 14.0	177	
-	1	1	8-22280-7	SPRING, COMPRESSION	176	
-	1	1	1752353-2	GUIDE PIN,HOLDDOWN	175	
-	1	1	1901680-2	GUIDE PIN,HOLDDOWN	174	
-	REF	REF	994970-2	COUNTER, MAGNETIC	164	
	1	1	2119955-2	ASSY, LUBRICATOR, END FEED	84	
-	1	1	455888-7	SPACER, CRIMPER	82	
-	1	1	1803607-4	DOCUMENTATION PACKAGE	71	
-	2	2	2-18032-2	SCR, SET, FLT PNT, M3 X 10.0	70	
-	1	1	2119740-1	TAG, IDENTIFICATION	67	
-	2	2	2168078-1	SCREW, DRIVE, RH, RoHS, 2 x .188	66	
-	1	1	1901681-1	HOLDDOWN, TERMINAL	65	
-	2	2	2168083-8	SCR, SKT HD CAP, RoHS, M4 X 16	64	
-	1	1	2168083-2	SCR, SKT HD CAP, RoHS, M4 X 8.0	60	
-	1	1	5-18022-5	SCR, HEX HD CAP, M4 X 6.0	59	
-	3	3	2168400-4	SHCS, LOW HEAD, RoHS, M4 X 8	57	
-	2	2	2168083-8	SCR, SKT HD CAP, RoHS, M4 X 16	56	
-	2	2	5018030-1	NUT, HEX, REG, RoHS, M3	54	
-	2	2	986965-8	NUT, LOCK, HEX, TORQUE (M4)	53	
-	1	1	1-5018030-0	NUT, HEX, REG, RoHS, M3.5	52	
-	1	1	2063961-1	FEED FINGER	51	
	1	1	1-1752354-2	STANDOFF,HOLD-DOWN	50	
-	1	1	18023-9	SCR, SKT HD CAP M4 X 6.0	49	
-	1	1	2119655-5	APPLICATOR BASIC ASSEMBLY, EF	46	
-	1	1	1803517-1	RAM ASSEMBLY, EF ATLANTIC	44	
-	1	1	1803602-1	SCR, BHSC, RoHS (M8 X 25)	41	
-	7	7	1-18028-2	WASHER, FLAT, REG M4	33	
-	1	1	2168083-9	SCR, SKT HD CAP, RoHS, M4 X 20	32	
-	1	1	2168083-8	SCR, SKT HD CAP, RoHS, M4 X 16	31	
-	2	2	2168083-2	SCR, SKT HD CAP, RoHS, M4 X 8.0	29	
-	1	1	240639-1	STRIPPER (MACHINING)	27	
-	2	2	1-2168083-5	SCR, SKT HD CAP, RoHS, M4 X 30	25	
-	1	1	1752371-6	PLATE, STRIP GUIDE	24	
-	1	1	240825-3	PLATE, STRIP HOLD DOWN	23	
-	2	2	2-22281-3	SPRING, COMPRESSION	22	
-	1	1	1803292-4	DRAG	20	
-	2	2	1901259-3	GUIDE, LOWER STRIP	18	
-	4	4	1-2079383-1	SCR, BHSC, RoHS (M6 X 12)	17	
-	1	1	4-240641-2	SPACER	16	
-	1	1	1752360-1	SPACER,HOLD-DOWN	13	
	1	1	240833-2	PLATE, REAR SHEAR	11	
-	-	-	-	-	10	
	1	1	690496-6	PLATE, FRONT SHEAR	9	
	1	2	1	3-1803001-1	ANVIL, COMBINATION, END FEED	8
	1	1	1	2217206-1	BLADE, SLUG	7
-	-	-	-	-	6	
-	1	1	1	6-240641-5	SPACER	5
-	1	1	1	238011-2	BLOCK, CRIMPER SPACER	4
	1	2	1	3-1803223-7	CRIMPER, INSULATION F PREMIUM	3
-	1	1	1	455888-1	SPACER, CRIMPER	2
	1	2	1	5-1803224-2	CRIMPER, WIRE	1
-	77	72	2	PART NO	DESCRIPTION	ITEM NO

ATLANTIC VERSION
Shown on sheets 1 of 4 & 2 of 4
(Pacific version shown on sheets 3 of 4 & 4 of 4)

DIMENSIONS:		TOLERANCES UNLESS OTHERWISE SPECIFIED:		MATERIAL:		FINISH:		WEIGHT:		SCALE:	
mm	0 PLC ±	1 PLC ±	2 PLC ±	3 PLC ±	4 PLC ±	ANGLES	FINISH	WT	SCALE	SHEET	REV
										1	E

LOC	DIST	REV	DATE	BY	APPV
A	66				

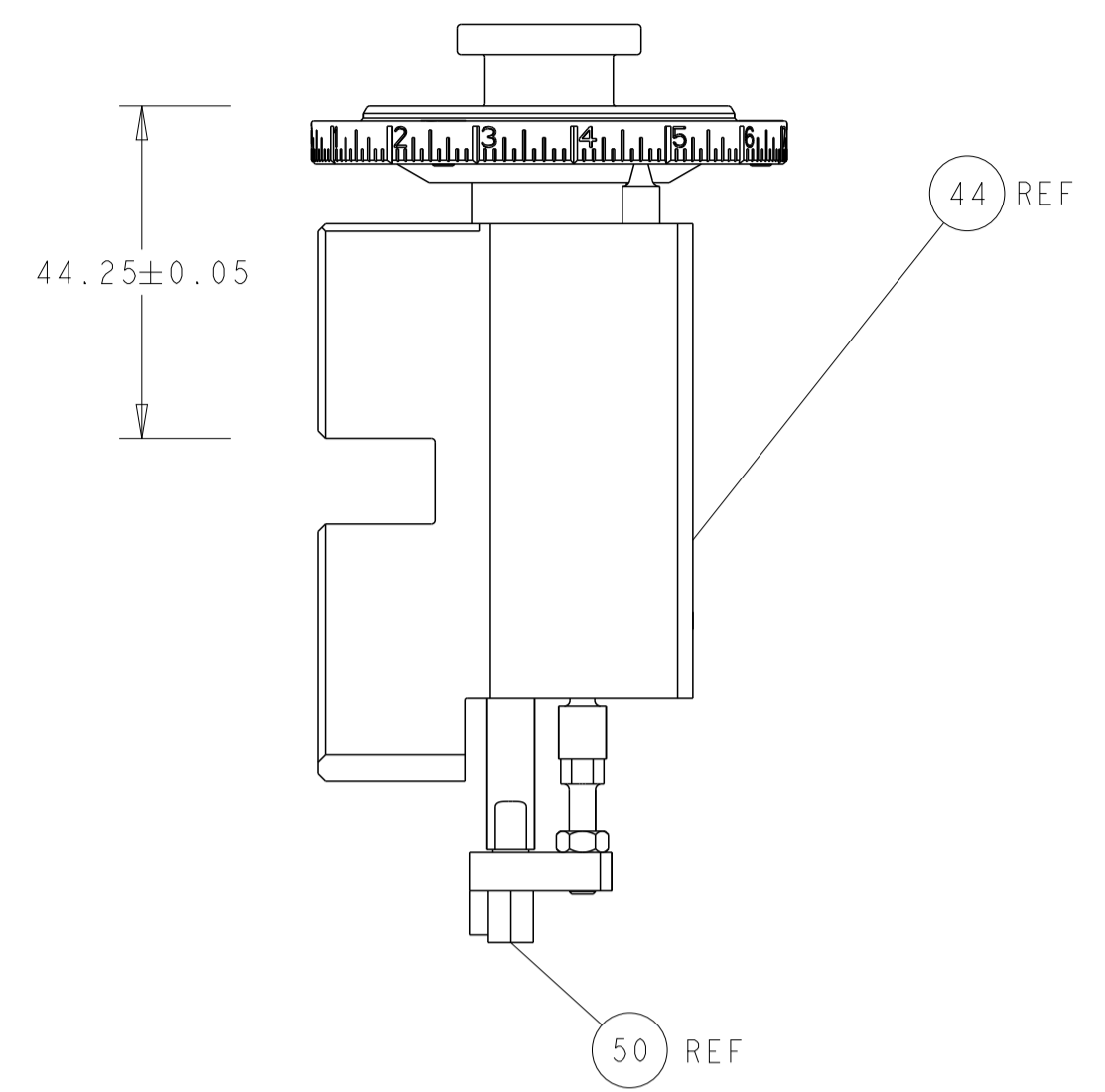

RAM AND HOLDDOWN SET-UP

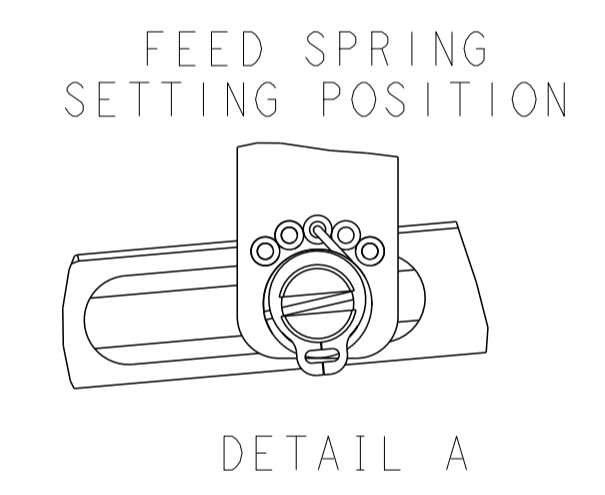
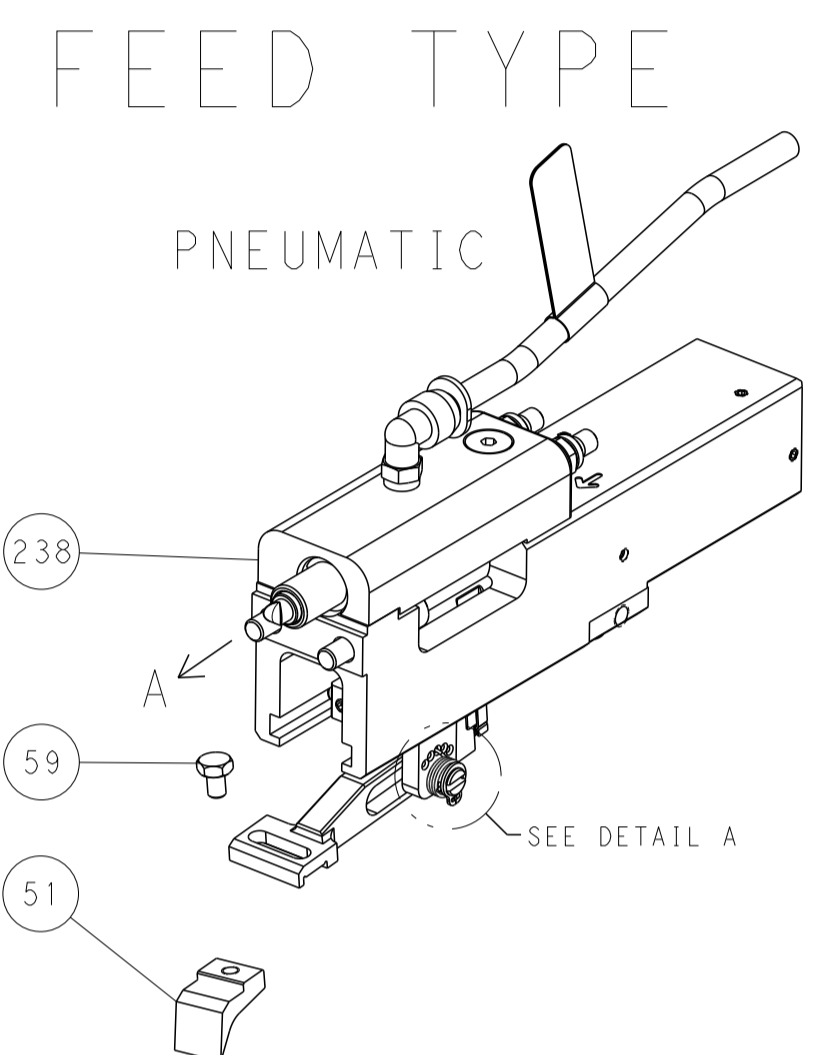
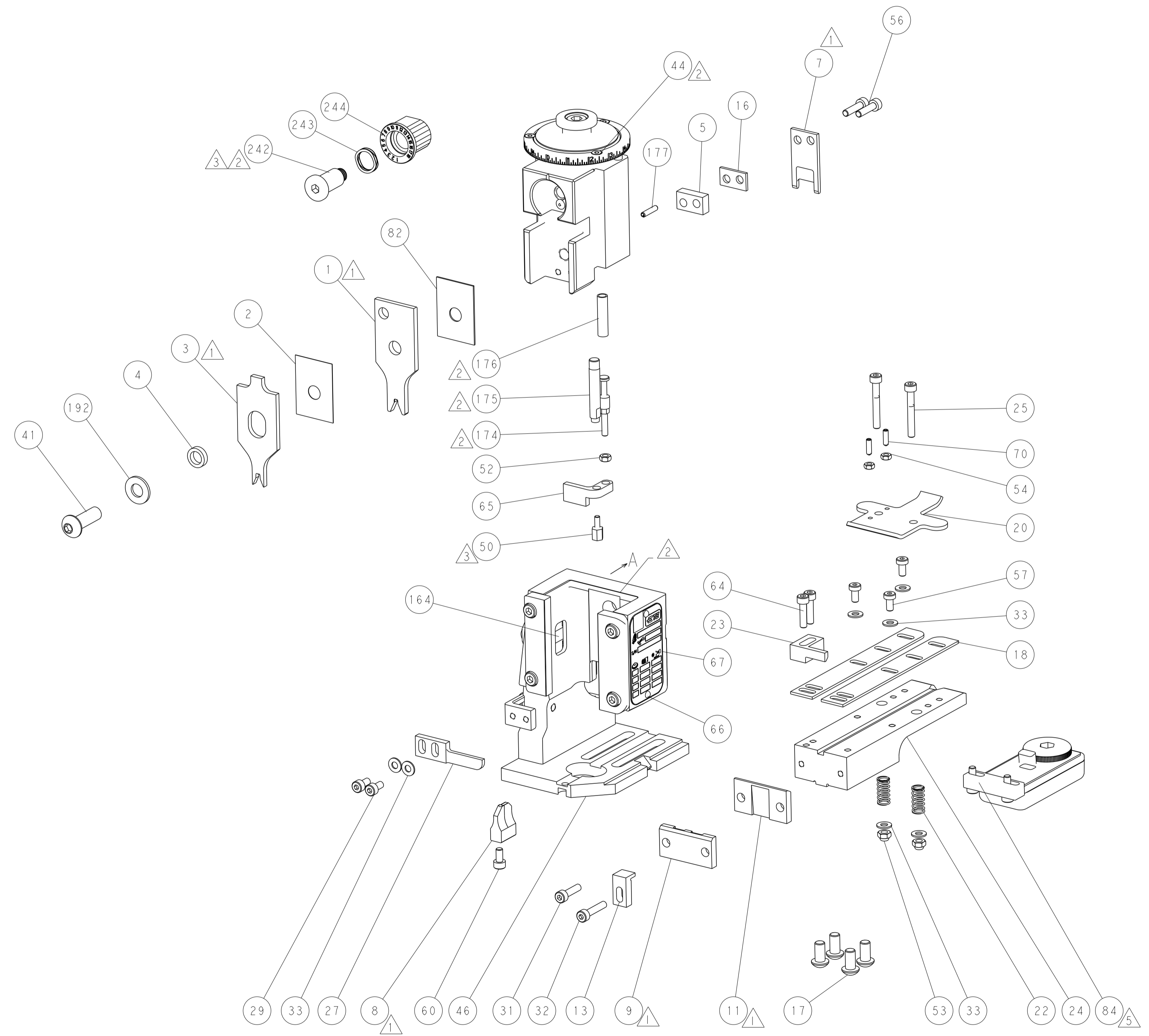

CAM POSITION

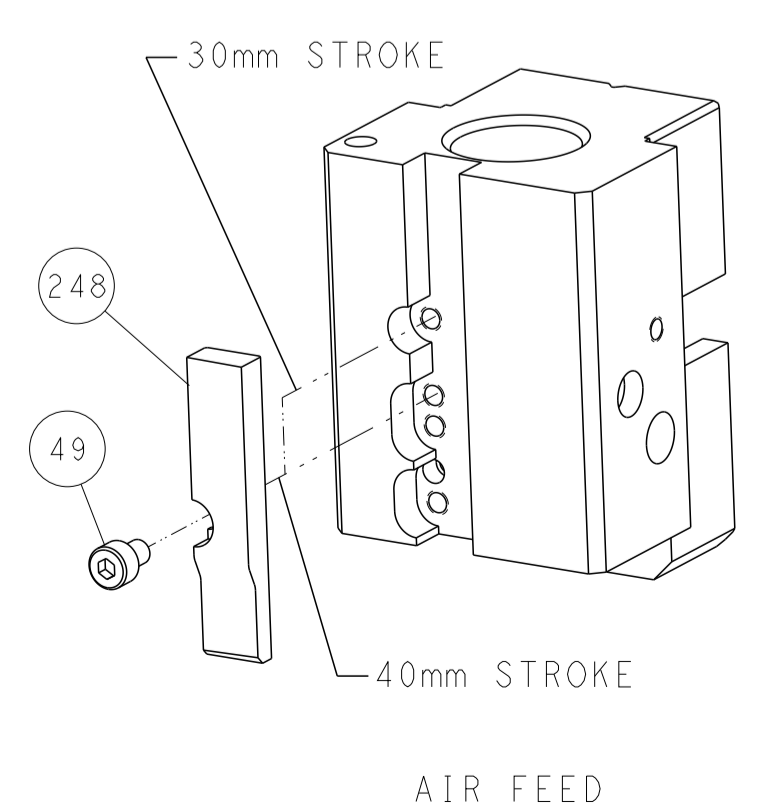

ATLANTIC VERSION
 Shown on sheets 1 of 4 & 2 of 4
 (Pacific version shown on sheets 3 of 4 & 4 of 4)

DIMENSIONS: mm 		TOLERANCES UNLESS OTHERWISE SPECIFIED: 0 PLC ± 1 PLC ± 2 PLC ± 3 PLC ± 4 PLC ± ANGLES ± FINISH ±		DWG: BOB_HIGMAN 03OCT2013 CHK: T_ELFIN 03OCT2013 APVD: M_CLIFFORD 03OCT2013 PRODUCT SPEC: APPLICATION SPEC: WEIGHT: - SCALE: 1:1		NAME: Ocean End Feed Applicator SIZE: A1 CAGE CODE: 00779 DRAWING NO: C=2150376 SHEET: 2 of 4 REV: E	
MATERIAL: - FINISH: -				RESTRICTED TO: - Customer Accessible Production Drawing		SHEETS 3 & 4 ARE NOT REQUIRED FOR ATLANTIC VERSION	

PART NUMBER	REVISION	DESCRIPTION	FEED TYPE
2-2150376-2	E	FINE CRIMP HEIGHT ADJUST	PNEUMATIC
7-2150376-7	C	CRIMP TOOLING KIT	-

PACIFIC VERSION TERMINATOR
 INTERFACE ADAPTER

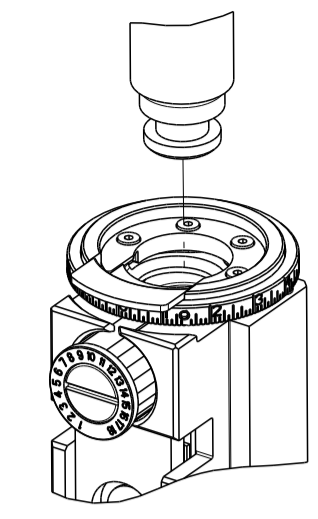

APPLICATOR DATA		
CRIMP	SIZE	TYPE
WIRE	2.28 mm [.090]	F
INSUL	3.00 mm [.118]	F
APPL INSTRUCTIONS 408-35043		

TERMINAL DATA: TE TERMINAL		TE CRIMP SPECIFICATION	
TERMINAL NAME: L.I.F. POSITIVE LOCK CONTACT 5MM SERIES			
WIRE STRIP LENGTH 3.50-4.50 mm [.138-.177 IN]		INSULATION DIAMETER RANGE 1.30-2.00 mm [.051-.079 IN]	
TERMINAL APPLICATION SPECIFICATION	114-15008	-	-
TERMINALS APPLIED			
TE TERMINAL	TE TERMINAL	TE TERMINAL	TE TERMINAL
141991-1	141991-3	1-141991-2	142685-3
141991-2	1-141991-1	2-141991-2	

WIRE SIZE	CRIMP HEIGHT mm [INCH]	CRIMP HEIGHT REFERENCE SETTING
0.6+0.35	1.42+/-0.05 [.056+/-0.002]	8.5
1.00mm2	1.42+/-0.05 [.056+/-0.002]	8.5
0.35+0.35	1.35+/-0.05 [.053+/-0.002]	9.4
0.60mm2	1.29+/-0.05 [.051+/-0.002]	10.1
0.35mm2	1.19+/-0.05 [.047+/-0.002]	11.4



- RECOMMENDED SPARE PARTS
- REFER TO SUPPLIED INSTRUCTION SHEET FOR CLEANING, LUBRICATION AND STORAGE OF APPLICATOR.
- APPLY PART NUMBER 2-23419-6 LOCTITE TO THREADS OF ITEM 242. APPLY PART NUMBER 1-23419-5 LOCTITE TO THREADS OF ITEM 50.
- CRIMP HEIGHT REFERENCE SETTING WAS THE SETTING USED WHEN THE APPLICATOR WAS QUALIFIED AT THE FACTORY. ADJUSTMENT MAY BE NECESSARY WHEN RUNNING APPLICATOR IN THE FIELD.
- TERMINAL LUBRICANT IS RECOMMENDED.
- UNLESS SPECIFIED OTHERWISE TORQUE VALUES SHALL BE USED PER DOCUMENT, 101-35000.
- TERMINAL PITCH NOT COMPATIBLE WITH MECHANICAL FEED.

***WARNING**
 ON INSTALLATION, SET WIRE DISC TO CRIMP HEIGHT REFERENCE SETTING FOR LARGEST WIRE SIZE. CRIMP HEIGHT REFERENCE SETTINGS GREATER THAN THE VALUE SHOWN MAY CAUSE DAMAGE TO THE CRIMP TOOLING. REFER TO THE INSTRUCTION SHEET FOR PROPER SETUP AND ADJUSTMENTS.

LOC	DIST	REVISIONS					
A	66	P	LTN	DESCRIPTION	DATE	OWN	APVD
-	-	-	-	SEE SHEET 1	-	-	-

-	1	2119082-9	CAM, SNAIL, INSULATION ADJUSTMENT	244
-	1	2079764-1	WASHER, WAVE SPRING, CREST-TO-CREST	243
-	1	2119083-1	RETAINER, INSULATION DIAL	242
-	1	2844940-4	AIR FEED MODULE	238
-	1	1-18028-0	WASHER, FLAT, REG M8	192
-	4	2079383-9	SCR, BHSC, RoHS (M6 X 20)	186
-	1	6-993111-6	PIN, SLOTTED SPRING 3.0 X 14.0	177
-	1	8-22280-7	SPRING, COMPRESSION	176
-	1	1752353-2	GUIDE PIN, HOLDDOWN	175
-	1	1901680-2	GUIDE PIN, HOLDDOWN	174
-	REF	994970-2	COUNTER, MAGNETIC	164
-	1	2119641-2	FEED CAM, AIR FEED	152
-	1	2168083-8	SCR, SKT HD CAP, RoHS, M4 X 16	144
-	1	2119655-6	APPLICATOR BASIC ASSEMBLY, EF	141
-	1	1803518-1	RAM ASSEMBLY, EF PACIFIC	140
-	1	2119955-2	ASSY, LUBRICATOR, END FEED	84
-	1	455888-7	SPACER, CRIMPER	82
-	1	1803607-4	DOCUMENTATION PACKAGE	71
-	2	2-18032-2	SCR, SET, FLT PNT, M3 X 10.0	70
-	1	2119740-1	TAG, IDENTIFICATION	67
-	2	2168078-1	SCREW, DRIVE, RH, RoHS, 2 x .188	66
-	1	1901681-1	HOLDDOWN, TERMINAL	65
-	2	2168083-8	SCR, SKT HD CAP, RoHS, M4 X 16	64
-	1	5-18022-5	SCR, HEX HD CAP, M4 X 6.0	59
-	3	2168400-4	SHCS, LOW HEAD, RoHS, M4 X 8	57
-	2	2168083-8	SCR, SKT HD CAP, RoHS, M4 X 16	56
-	2	5018030-1	NUT, HEX, REG, RoHS, M3	54
-	2	986965-8	NUT, LOCK, HEX, TORQUE (M4)	53
-	1	1-5018030-0	NUT, HEX, REG, RoHS, M3.5	52
-	1	2063961-1	FEED FINGER	51
-	1	1-1752354-2	STANDOFF, HOLD-DOWN	50
-	1	18023-9	SCR, SKT HD CAP M4 X 6.0	49
-	1	1803602-1	SCR, BHSC, RoHS (M8 X 25)	41
-	7	1-18028-2	WASHER, FLAT, REG M4	33
-	1	2168083-9	SCR, SKT HD CAP, RoHS, M4 X 20	32
-	1	2168083-8	SCR, SKT HD CAP, RoHS, M4 X 16	31
-	2	2168083-2	SCR, SKT HD CAP, RoHS, M4 X 8.0	29
-	1	240639-1	STRIPPER (MACHINING)	27
-	2	1-2168083-5	SCR, SKT HD CAP, RoHS, M4 X 30	25
-	1	1752371-6	PLATE, STRIP GUIDE	24
-	1	240825-3	PLATE, STRIP HOLD DOWN	23
-	2	2-22281-3	SPRING, COMPRESSION	22
-	1	1803292-4	DRAG	20
-	2	1901259-3	GUIDE, LOWER STRIP	18
-	1	4-240641-2	SPACER	16
-	1	1752360-1	SPACER, HOLD-DOWN	13
-	1	240833-2	PLATE, REAR SHEAR	11
-	-	-	-	10
-	1	690496-6	PLATE, FRONT SHEAR	9
-	1	3-1803001-1	ANVIL, COMBINATION, END FEED	8
-	1	2217206-1	BLADE, SLUG	7
-	-	-	-	6
-	1	6-240641-5	SPACER	5
-	1	238011-2	BLOCK, CRIMPER SPACER	4
-	1	3-1803223-7	CRIMPER, INSULATION F PREMIUM	3
-	1	455888-1	SPACER, CRIMPER	2
-	1	5-1803224-2	CRIMPER, WIRE	1
-	77-22	PART NO	DESCRIPTION	ITEM NO

PACIFIC VERSION
 Shown on sheets 3 of 4 & 4 of 4
 (Atlantic version shown on sheets 1 of 4 & 2 of 4)

DIMENSIONS: mm 		TOLERANCES UNLESS OTHERWISE SPECIFIED: 0 PLC ± 1 PLC ± 2 PLC ± 3 PLC ± 4 PLC ± ANGLES ± FINISH		DWN BOB HIGMAN 03OCT2013 CHK T. ELBIN 03OCT2013 APVD M. CLIFFORD 03OCT2013 PRODUCT SPEC APPLICATION SPEC WEIGHT SCALE 1:1		NAME Ocean End Feed Applicator SIZE CAGE CODE DRAWING NO RESTRICTED TO A1 00779 C=2150376 3 OF 4 REV E	
Customer Accessible Production Drawing				SCALE 1:1 SHEET 3 OF 4 REV E			

LOC	DIST	REVISIONS			
P	LTN	DESCRIPTION	DATE	DMN	APVD
A	66	SEE SHEET 1	-	-	-

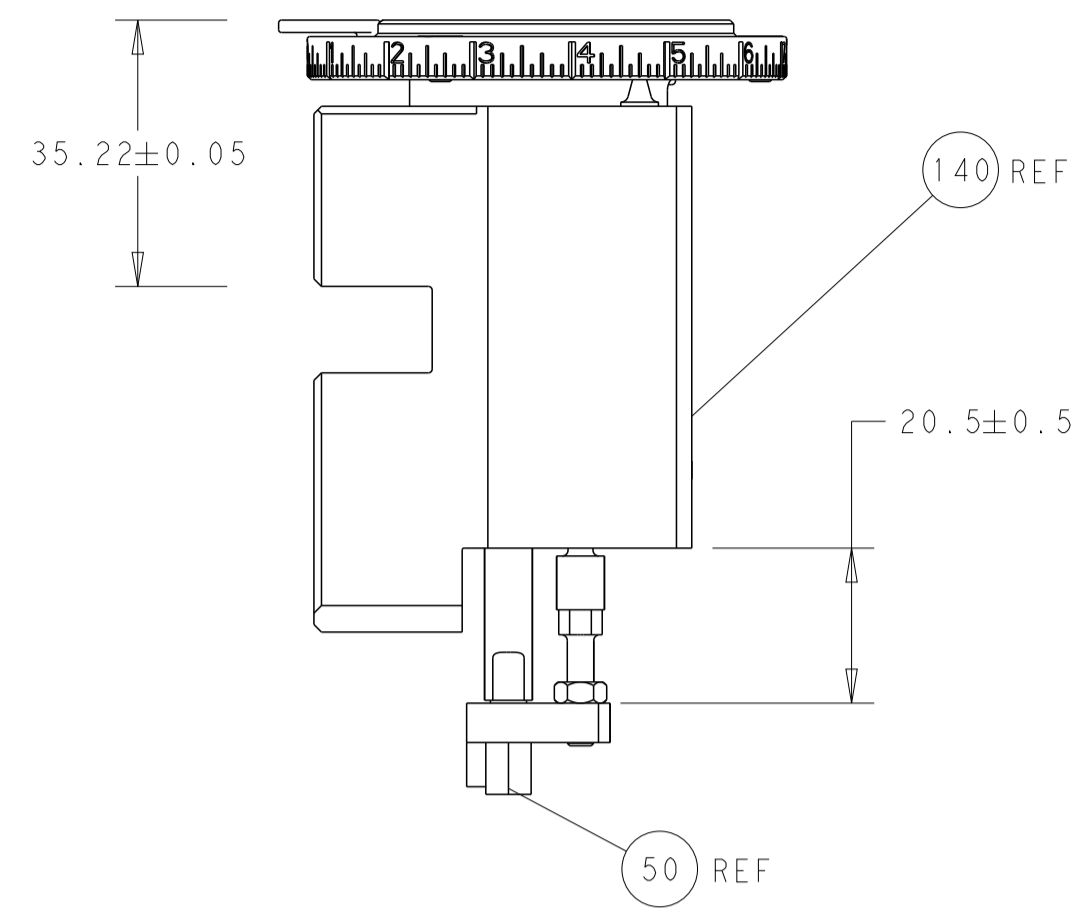

RAM AND HOLDDOWN SET-UP

FEED TYPE

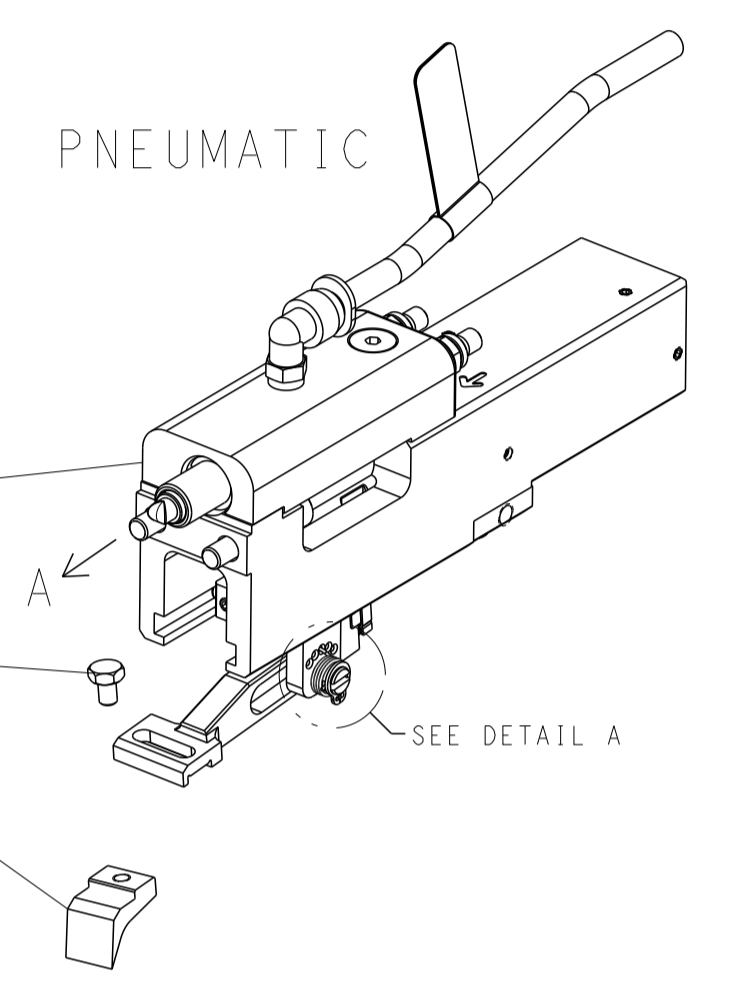

FEED SPRING SETTING POSITION

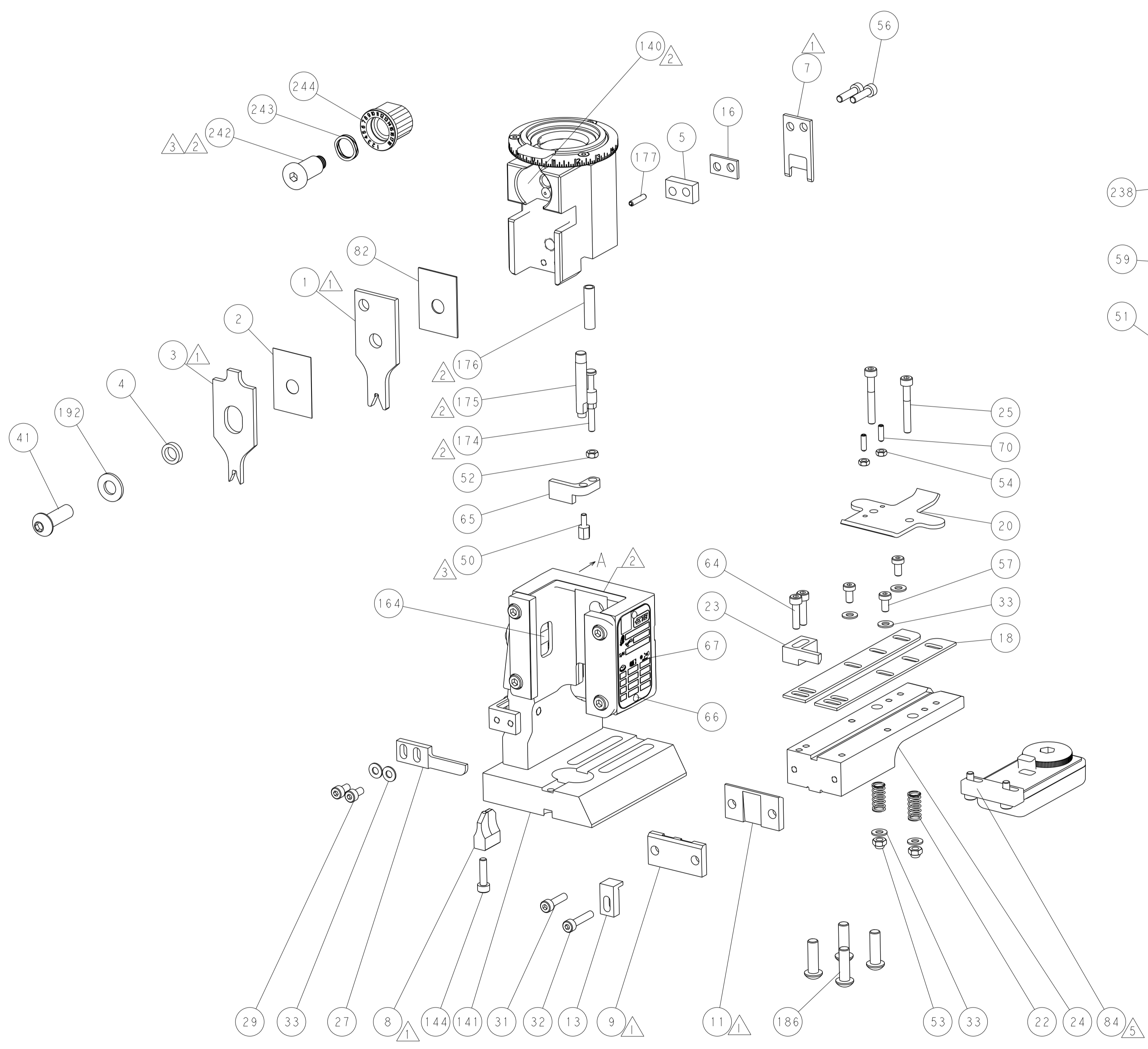
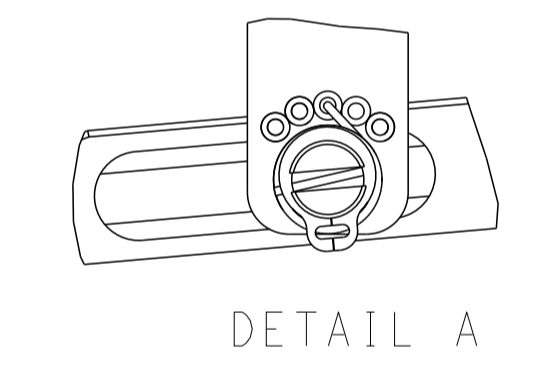

CAM POSITION

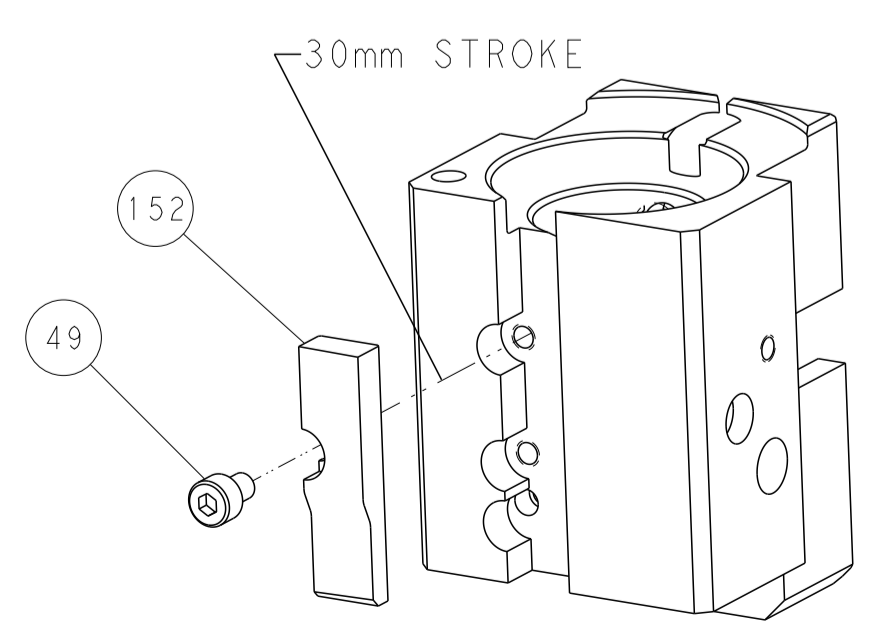

AIR FEED

PACIFIC VERSION
 Shown on sheets 3 of 4 & 4 of 4
 (Atlantic version shown on sheets 1 of 4 & 2 of 4)

<small>THIS DRAWING IS UNPUBLISHED. RELEASED FOR PUBLICATION BY TYCO ELECTRONICS CORPORATION. ALL RIGHTS RESERVED.</small>		DWN BOB_HIGMAN 03OCT2013 CHK T_ELFIN 03OCT2013 APVD M_CLIFFORD 03OCT2013 PRODUCT SPEC APPLICATION SPEC WEIGHT Customer Accessible Production Drawing	NAME Ocean End Feed Applicator SIZE CAGE CODE DRAWING NO A 00779 C=2150376 SCALE 1:1 SHEET 4 OF 4 REV E	RESTRICTED TO -
DIMENSIONS: mm TOLERANCES UNLESS OTHERWISE SPECIFIED: 0 PLC ± 1 PLC ± 2 PLC ± 3 PLC ± 4 PLC ± ANGLES ± MATERIAL FINISH	TOLERANCES UNLESS OTHERWISE SPECIFIED: 0 PLC ± 1 PLC ± 2 PLC ± 3 PLC ± 4 PLC ± ANGLES ± MATERIAL FINISH	STE TE Connectivity Harrisburg, PA 17105-3608		