



# MAX9788 Evaluation Kit

## General Description

The MAX9788 evaluation kit (EV kit) is a fully assembled and tested PCB that uses the MAX9788 Class G amplifier to drive a bridge-tied-load (BTL) ceramic speaker in portable audio applications. Designed to operate from a 2.7V to 5.5VDC power supply, the EV kit accepts a single-ended or differential input signal and provides a fully differential output capable of delivering greater than 14V<sub>P-P</sub> into a ceramic speaker.

## Component List

DESIGNATION	QTY	DESCRIPTION
C1, C2, C3	3	0.1 $\mu$ F $\pm$ 10%, 6.3V X5R ceramic capacitors (0402) Murata GRM155R60J104K
C5, C6	2	1 $\mu$ F $\pm$ 10%, 6.3V X5R ceramic capacitors (0402) Murata GRM155R60J105K
C7	1	4.7 $\mu$ F $\pm$ 10%, 6.3V X5R ceramic capacitor (0603) Murata GRM188R60J475K
C8, C9, C10	3	10 $\mu$ F $\pm$ 20%, 6.3V X5R ceramic capacitors (0603) Murata GRM188R60J106M
C11, C12	0	Not installed, capacitors (0603)
JU1	1	3-pin header
OUT	1	3.5mm stereo phone jack (3-position, non-switch)
R1-R4	4	10k $\Omega$ $\pm$ 0.5% precision thick-film chip resistors (0603) Panasonic ERJ3RBD1002V
R5	1	100k $\Omega$ $\pm$ 1% resistor (0603)
R6, R7	2	5.1 $\Omega$ $\pm$ 5% resistors (0805)
U1	1	MAX9788EBP+ (20-bump, 4 x 5 UCSP, 2mm x 2.5mm)
—	1	Shunt
—	1	PCB: MAX9788EVKIT+

## Features

- ◆ 5V Single-Supply Operation
- ◆ Fully Differential Output
- ◆ Delivers Greater than 14V<sub>P-P</sub> into a Ceramic Speaker
- ◆ Evaluates the MAX9788 in a 20-Bump UCSP (2mm x 2.5mm) Package
- ◆ The MAX9788 IC Also Available in 28-Pin (4mm x 4mm) TQFN Package
- ◆ Fully Assembled and Tested

## Ordering Information

PART	TEMP RANGE	IC PACKAGE
MAX9788EVKIT+	0°C to +70°C*	20 UCSP-20 (2mm x 2.5mm)

+ Denotes a lead-free and RoHS-compliant EV kit.

\* This limited temperature range applies to the EV kit PCB only. The MAX9788 IC temperature range is -40°C to +85°C.

## Component Suppliers

SUPPLIER	PHONE	WEBSITE
Murata Mfg. Co., Ltd.	770-436-1300	www.murata.com
Panasonic Corp.	714-373-7366	www.panasonic.com

**Note:** Indicate that you are using the MAX9788 when contacting these component suppliers.

Evaluates: MAX9788

# MAX9788 Evaluation Kit

## Quick Start

### Recommended Equipment

- 5V, 1A power supply
- Audio source (i.e., CD player, MP3 player)
- One ceramic speaker (recommended suppliers: Murata, Taiyo Yuden)

### Procedure

The MAX9788 EV kit is fully assembled and tested. Follow the steps below to verify board operation.

**Caution:** Do not turn on the power supply until all connections are completed.

- 1) Install a shunt across pins 1-2 of jumper JU1 (EV kit ON).
- 2) Connect the ceramic speaker across the OUT- and OUT+ pads.
- 3) Connect the positive terminal of the power supply to the VCC pad and the ground terminal to the GND pad.
- 4) Connect the positive terminal of the audio source to the IN+ pad.
- 5) Connect the negative terminal of the audio source to the IN- pad. Connect the IN- pad to GND if the audio source is single ended.
- 6) Connect the ground terminal of the audio source to the GND pad.
- 7) Turn on the audio source.
- 8) Turn on the power supply.

## Detailed Description

The MAX9788 EV kit features the MAX9788 Class G amplifier IC, designed to drive a ceramic speaker in a BTL configuration. The EV kit operates from a DC power supply that provides 2.7V to 5.5V and 1A of current.

The EV kit accepts single-ended or a differential audio input and provides a fully differential output. The audio input source is amplified to drive greater than 14V<sub>p-p</sub> into a ceramic speaker.

### Customizing the Gain

The MAX9788 EV kit is shipped with a gain of +12dB. Change the resistors (R1–R4) to customize the gain of the EV kit (refer to the MAX9788 IC data sheet for details).

### Jumper Selection

#### Shutdown Mode ( $\overline{\text{SHDN}}$ )

Jumper JU1 controls the shutdown pin ( $\overline{\text{SHDN}}$ ) of the MAX9788 IC. The shutdown pin is also controlled by an external logic controller connected to the EV kit  $\overline{\text{SHDN}}$  pad. Remove the shunt from jumper JU1 before connecting an external controller to the  $\overline{\text{SHDN}}$  pad. See Table 1 for shunt positions.

**Table 1. Shutdown Mode, JU1 Jumper Selection**

SHUNT POSITION	MAX9788 $\overline{\text{SHDN}}$ PIN CONNECTED TO	EV KIT FUNCTION
1-2*	VDD	EV kit enabled
2-3	GND	Shutdown mode
None	External logic controller	$\overline{\text{SHDN}}$ driven by external logic controller. Shutdown is active low and 1.8V logic compliant.

\*Default position.

# MAX9788 Evaluation Kit

Evaluates: MAX9788

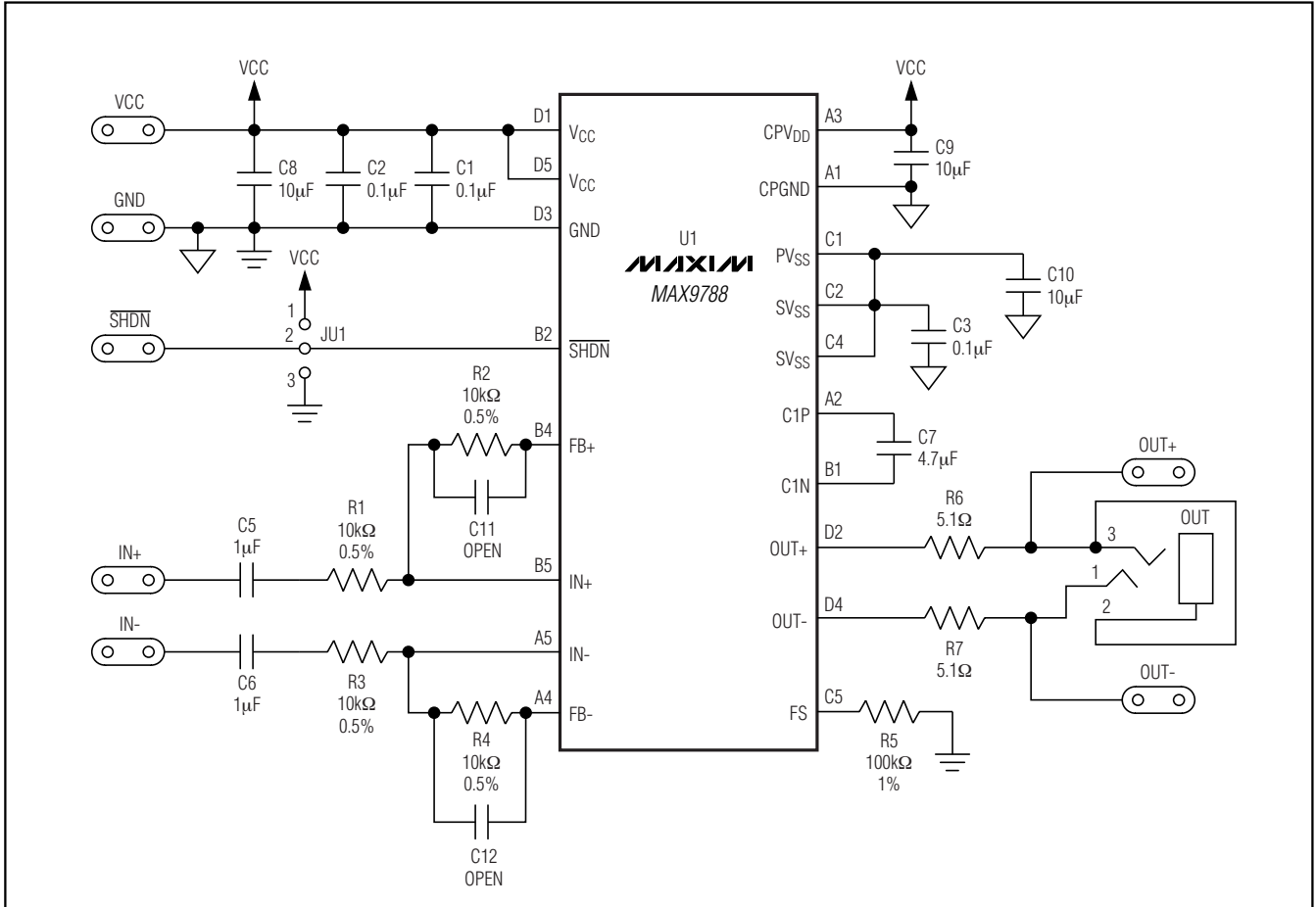

Figure 1. MAX9788 EV Kit Schematic

# MAX9788 Evaluation Kit

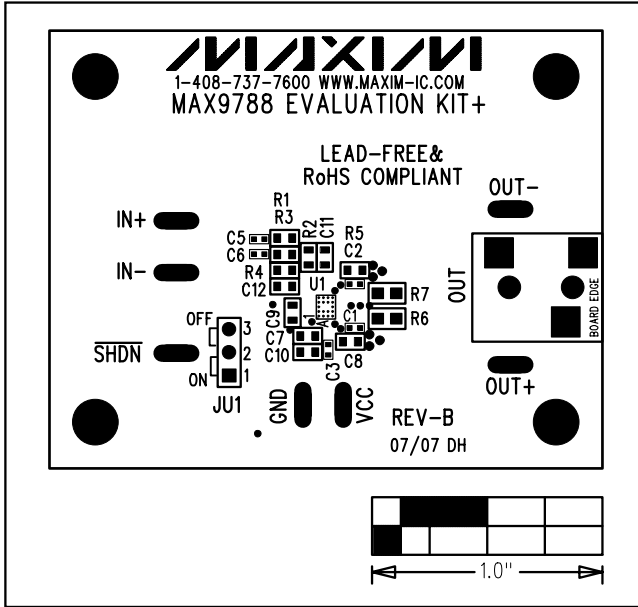

Figure 2. MAX9788 EV Kit Component Placement Guide—Component Side

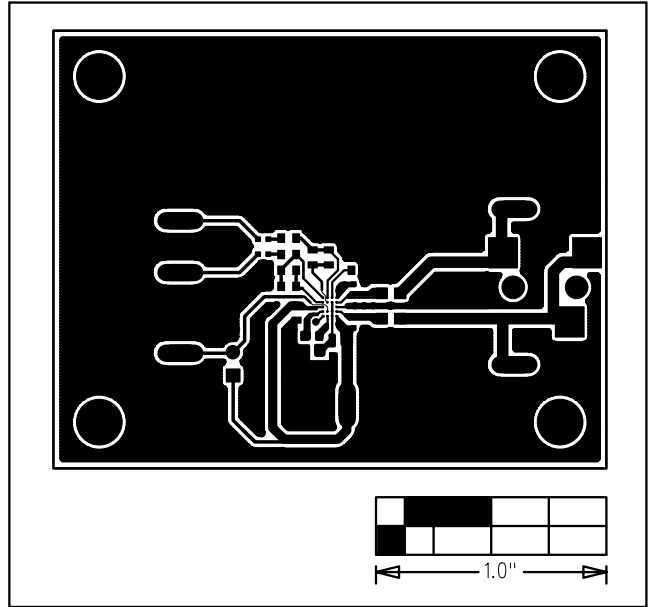

Figure 3. MAX9788 EV Kit PCB Layout—Component Side

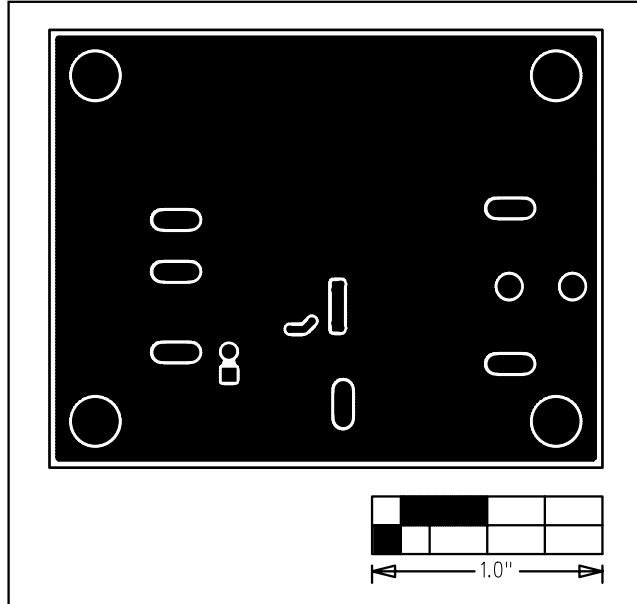

Figure 4. MAX9788 EV Kit PCB Layout—Solder Side

## Revision History

Pages changed at Rev 2: 1, 3, 4

Maxim cannot assume responsibility for use of any circuitry other than circuitry entirely embodied in a Maxim product. No circuit patent licenses are implied. Maxim reserves the right to change the circuitry and specifications without notice at any time.

4 **Maxim Integrated Products, 120 San Gabriel Drive, Sunnyvale, CA 94086 408-737-7600**

© 2007 Maxim Integrated Products

**MAXIM** is a registered trademark of Maxim Integrated Products, Inc.