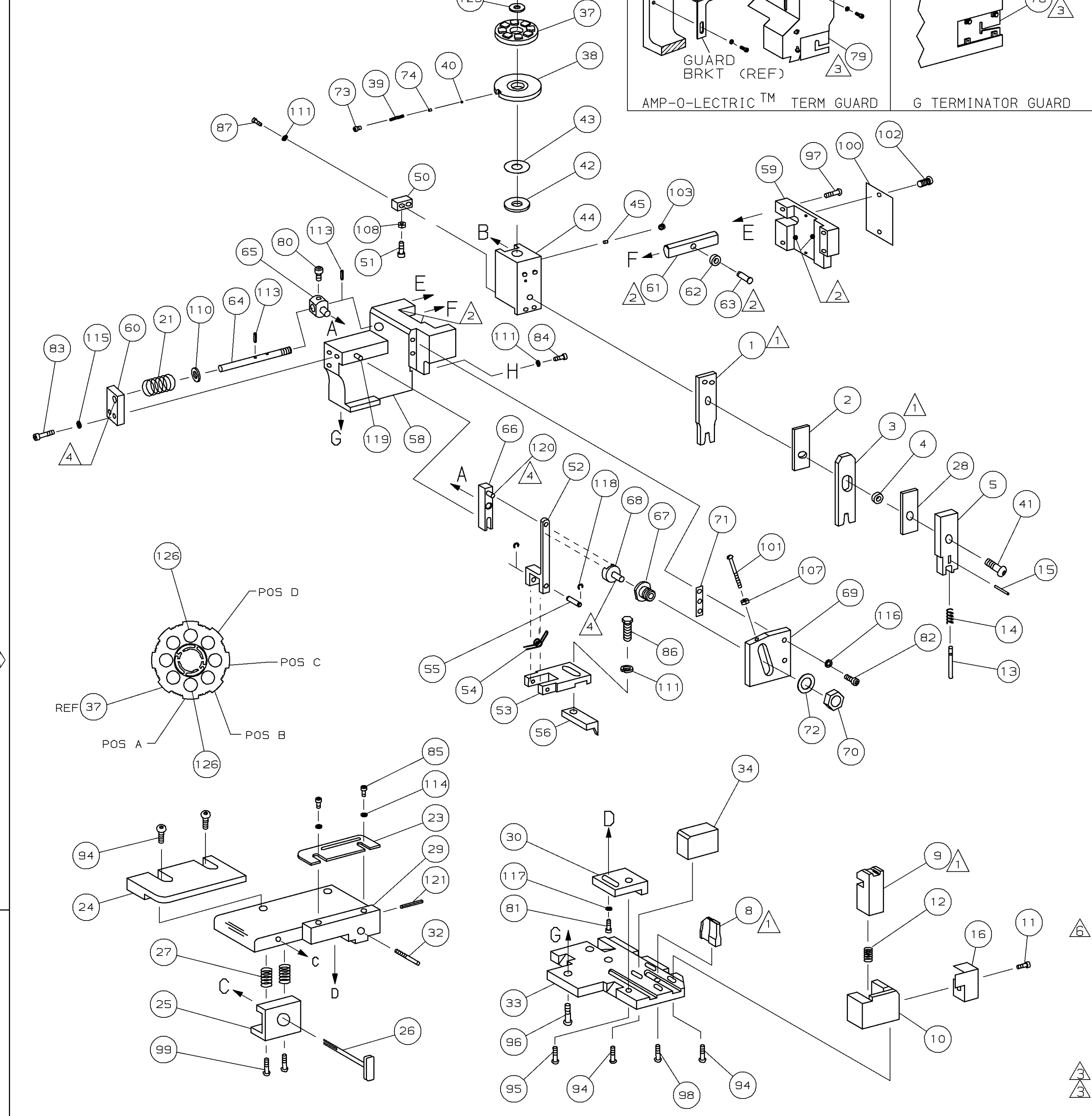
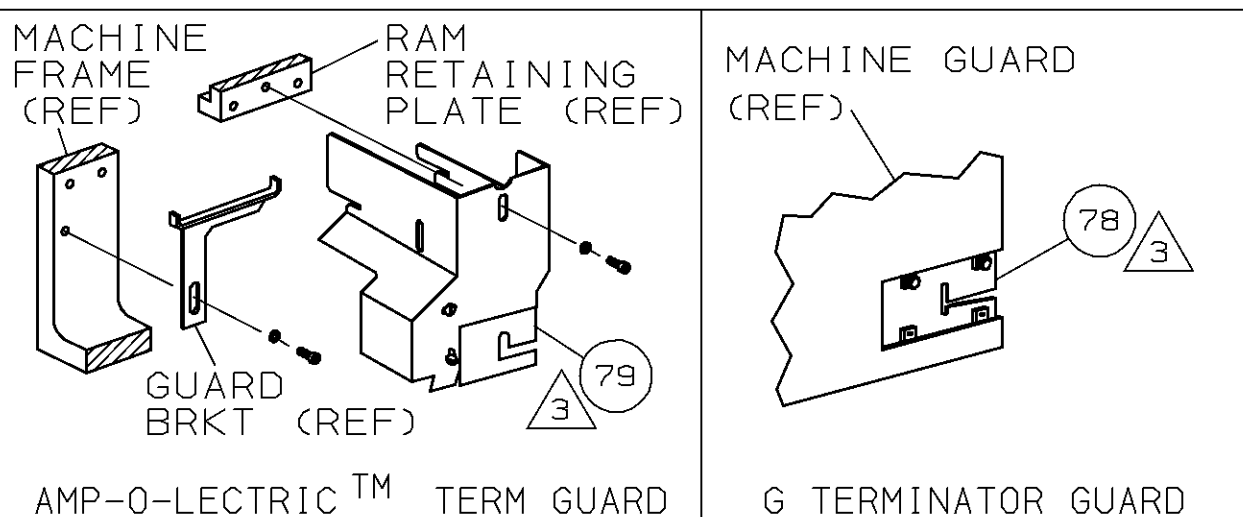
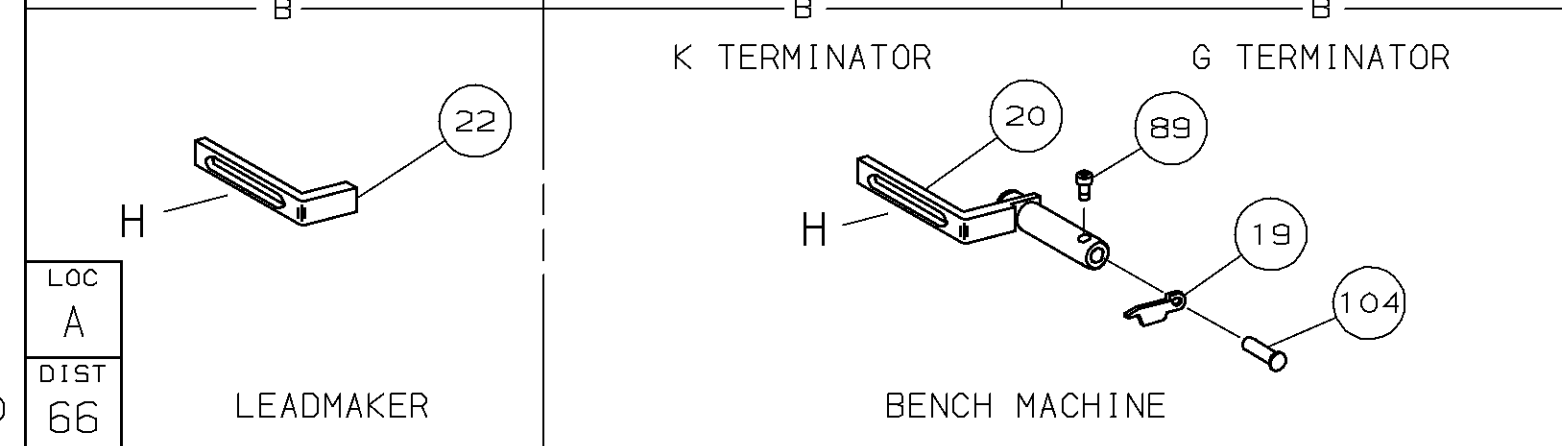
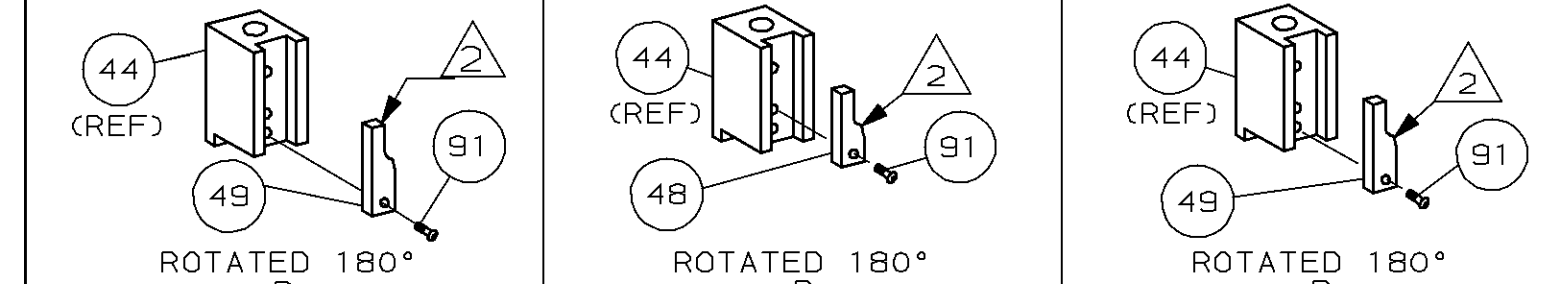

Table with columns: PART NUMBER, REV, FIRST USED



POST FEED 1 5/8 STROKE PRE FEED 1 1/8 STROKE PRE FEED 1 5/8 STROKE



TERMINAL NAME: TERMINAL, PIN. Table with columns: CRIMP DATA (COMP, WIRE SIZE), WIRE STRIP LENGTH, TERM APPL SPEC, FEED, APPL INSTRUCTION, SET UP GAGE, LAYOUT. Includes a detailed parts list table with columns: QTY REQD PER ASSY, PART NO, DESCRIPTION, ITEM NO.

Table with columns: LEADMAKER, MECH POST FEED, MECH PRE FEED, PART NO, DESCRIPTION, ITEM NO. Includes assembly instructions and revision notes.

1. RECOMMENDED SPARE PARTS.
2. GREASE LIGHTLY.
3. GUARD MUST BE IN PLACE WHEN OPERATING APPLICATOR IN A BENCH MACHINE.
4. LUBRICATE DAILY USING NO. 20 MACHINE OIL.
5. ITEMS WITH QTY OF REF SPECIFIED (EXCEPT ITEMS 78 AND 79) ARE USED ON ITEM 46.
6. CUT TO LENGTH AT ASSY
7. INSULATION C.H. .118±.002 [3.00±0.05mm] USE INSULATION DISC (ITEM 38) PAD 4.

THIS DRAWING IS A CONTROLLED DOCUMENT.

THIS DRAWING IS UNPUBLISHED. BY AMP INCORPORATED. ALL RIGHTS RESERVED. 19