

NOTES:

1. MATERIAL:

- CAGE: NICKEL SILVER
- GASKET FLANGE: STAINLESS STEEL
- EMI SPRINGS: COPPER ALLOY
- LIGHT PIPES: POLYCARBONATE 94V-0(OPTIONAL)
- GASKET - CORE MATERIAL 94V-0
- CONNECTOR HOUSING: GLASS FILLED THERMOPLASTIC, UL: 94V-0. COLOR: BLACK
- TERMINALS: HIGH PERFORMANCE COPPER ALLOY
- ELASTOMERIC GASKET: SILVER IMPREGNATED SILICONE

2. FINISH:

- CAGE & GASKET FLANGE: UNPLATED
- EMI SPRINGS: 2.54µm NICKEL OVERALL
- TERMINALS: CONTACT AREA: 0.76 µm MIN. HARD GOLD OVER 3.8 µm MIN. NICKEL.
- COMPLIANT TAIL: 0.7 - 1.5 µm MATTE TIN OVER 0.7 - 1.5 µm NICKEL

3. PACKAGING: PRODUCT PACKAGED IN TRAYS AND CARTONS

4. ALL VISIBLE EXTERIOR SURFACES TO BE CLASS "B" OR BETTER, EXCEPT FOR UNDERSIDE OF THE CAGE WHICH IS CLASS "C" AND THE FRONT SURFACE OF THE MIDSECTION EMI SHIELD WHICH IS TO BE A CLASS "A" SURFACE, AND ARE ALL TO CONFORM TO THE MOLEX COSMETIC SPEC ES-171233-0001.

5. CONNECTOR MATES WITH PLUG CABLE SERIES 74757 AND 74758

6. DATE CODE LOCATION SHOWN, DATE CODE FORMAT:DDD Y= YEAR
DDD= DAY OF THE YEAR Y= YEAR

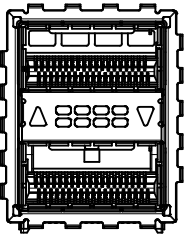
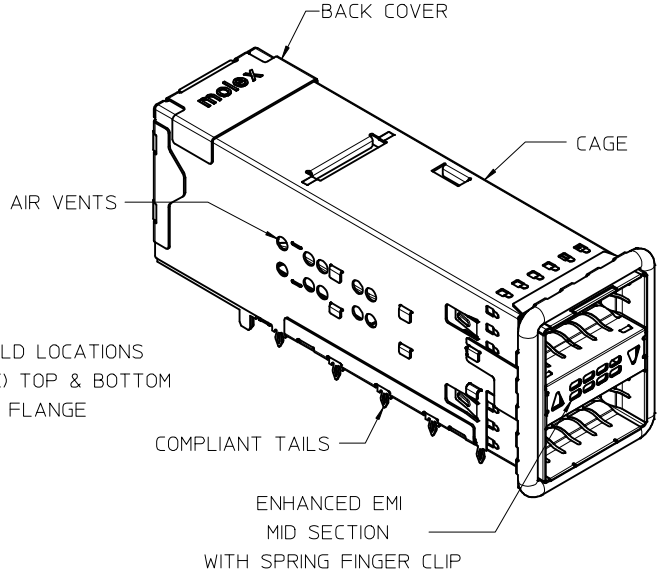
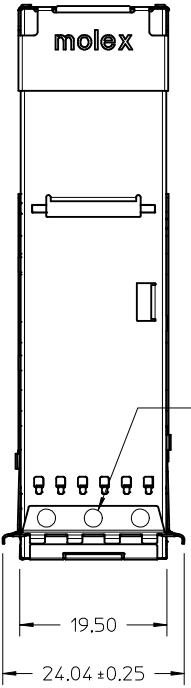

76871-1108 SHOWN W/O GASKET, SEE SHEET 2 FOR OTHER OPTIONS

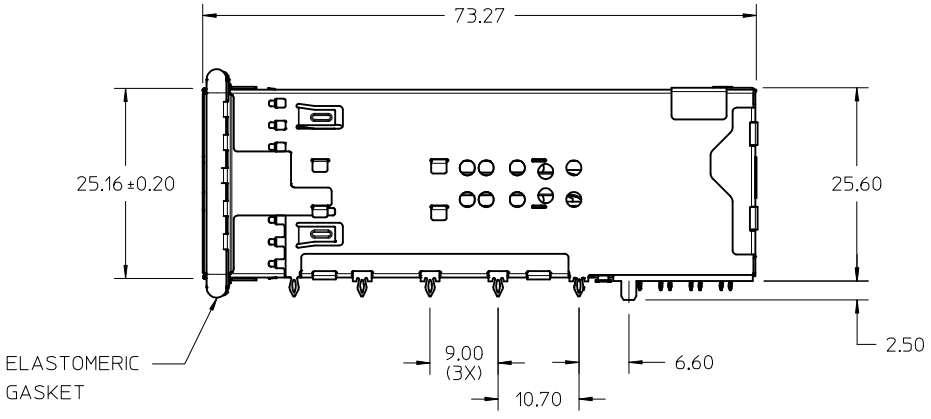

DATE CODE LOCATION SEE NOTE 6

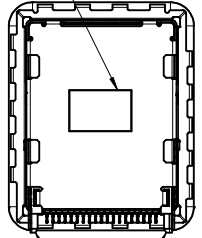

LOCATING PEGS

REV	DESCRIPTION	DATE	APPROVED BY	CHKD:	DRWN/HAVRY	EC NO:	CORRECTED PIN #1 CALLOUT
1		2014/03/17	MBANAKIS			UCP2014-4000	
2		2014/03/17	MBANAKIS				

QUALITY SYMBOLS	
	=0
	=0
	=0

GENERAL TOLERANCES (UNLESS SPECIFIED)	
mm	INCH
4 PLACES ± .13	± .005
3 PLACES ± .13	± .005
2 PLACES ± 0.13	± .005
1 PLACE ± 0.25	± .010
ANGULAR ± 1/2°	

DIMENSION STYLE		SCALE	DESIGN UNITS	THIRD ANGLE PROJECTION
MM ONLY		2:1	METRIC	
DRAWN BY: JGONZALEZ01		DATE: 2011/08/01		TITLE: QSFP 2X1 ASSEMBLY ENHANCED MID SECTION & CLAW FLANGE
CHECKED BY: KREGNIER		DATE: 2011/08/01		
APPROVED BY: MBANAKIS		DATE: 2011/12/14		
MATERIAL NO.		DOCUMENT NO.		SHEET NO.
SEE SHEET 2		SD-76871-1100		1 OF 3
THIS DRAWING CONTAINS INFORMATION THAT IS PROPRIETARY TO MOLEX INCORPORATED AND SHOULD NOT BE USED WITHOUT WRITTEN PERMISSION				

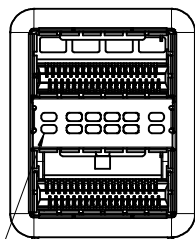

NO LIGHT PIPES
AIR FLOW VENTS

P/N: 76871-1105

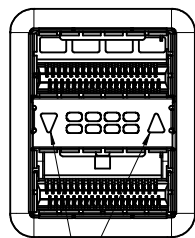

PORT ACTIVITY INDICATORS
LEFT DOWN / RIGHT UP

P/N: 76871-1106

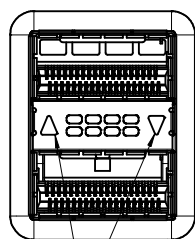

PORT ACTIVITY INDICATORS
LEFT UP / RIGHT DOWN

P/N: 76871-1108

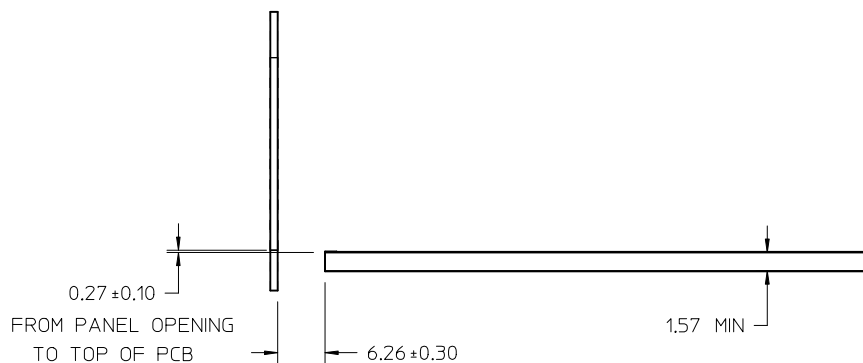
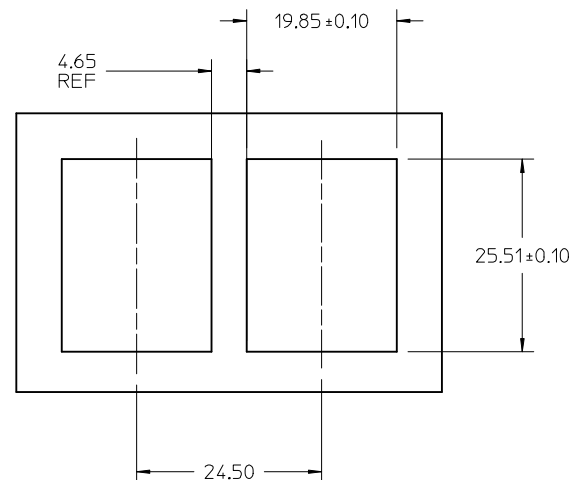

RECOMMENDED PANEL CUT-OUT

SEE SHEET 1 EC NO: UCP2014-4000 DRW: HAVERY 2014/03/27 CHKD: APPR: MBANAKIS 2014/03/31	QUALITY SYMBOLS ▽=0 ▽=0 ▽=0	GENERAL TOLERANCES (UNLESS SPECIFIED) <table border="1"> <tr> <td></td> <td>mm</td> <td>INCH</td> </tr> <tr> <td>4 PLACES</td> <td>± 0.13</td> <td>± 0.005</td> </tr> <tr> <td>3 PLACES</td> <td>± 0.25</td> <td>± 0.010</td> </tr> <tr> <td>2 PLACES</td> <td>± 0.38</td> <td>± 0.015</td> </tr> <tr> <td>1 PLACE</td> <td>± 0.51</td> <td>± 0.020</td> </tr> </table> ANGULAR ±1/2°		mm	INCH	4 PLACES	± 0.13	± 0.005	3 PLACES	± 0.25	± 0.010	2 PLACES	± 0.38	± 0.015	1 PLACE	± 0.51	± 0.020	DIMENSION STYLE MM ONLY DRAWN BY DATE JGONZALEZ01 2011/08/01 CHECKED BY DATE KREGNIER 2011/08/01 APPROVED BY DATE MBANAKIS 2011/12/14	SCALE 2:1 DESIGN UNITS METRIC THIRD ANGLE PROJECTION	TITLE QSFP 2X1 ASSEMBLY ENHANCED MID SECTION & CLAW FLANGE
		mm	INCH																	
	4 PLACES	± 0.13	± 0.005																	
	3 PLACES	± 0.25	± 0.010																	
2 PLACES	± 0.38	± 0.015																		
1 PLACE	± 0.51	± 0.020																		
DRAFT WHERE APPLICABLE MUST REMAIN WITHIN DIMENSIONS	MATERIAL NO. SEE OPTIONS	MOLEX INCORPORATED DOCUMENT NO. SD-76871-1100	SHEET NO. 2 OF 3																	
THIS DRAWING CONTAINS INFORMATION THAT IS PROPRIETARY TO MOLEX INCORPORATED AND SHOULD NOT BE USED WITHOUT WRITTEN PERMISSION																				

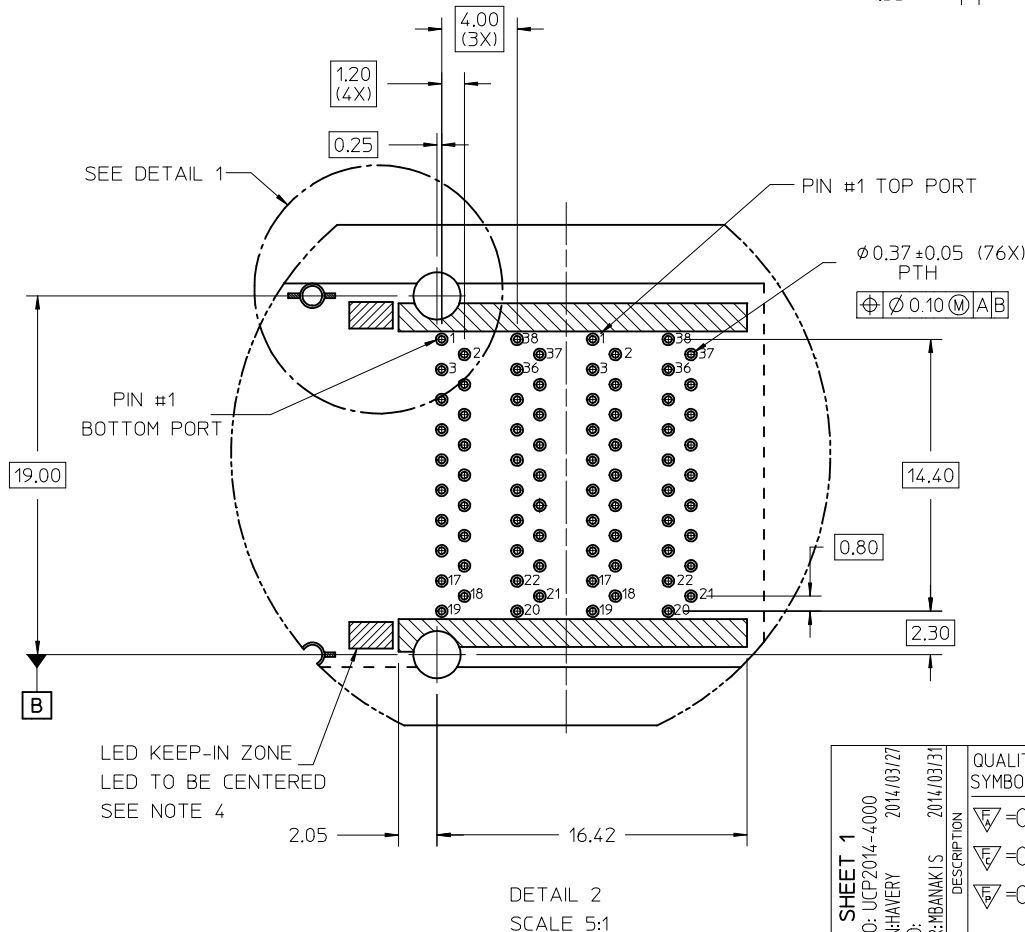
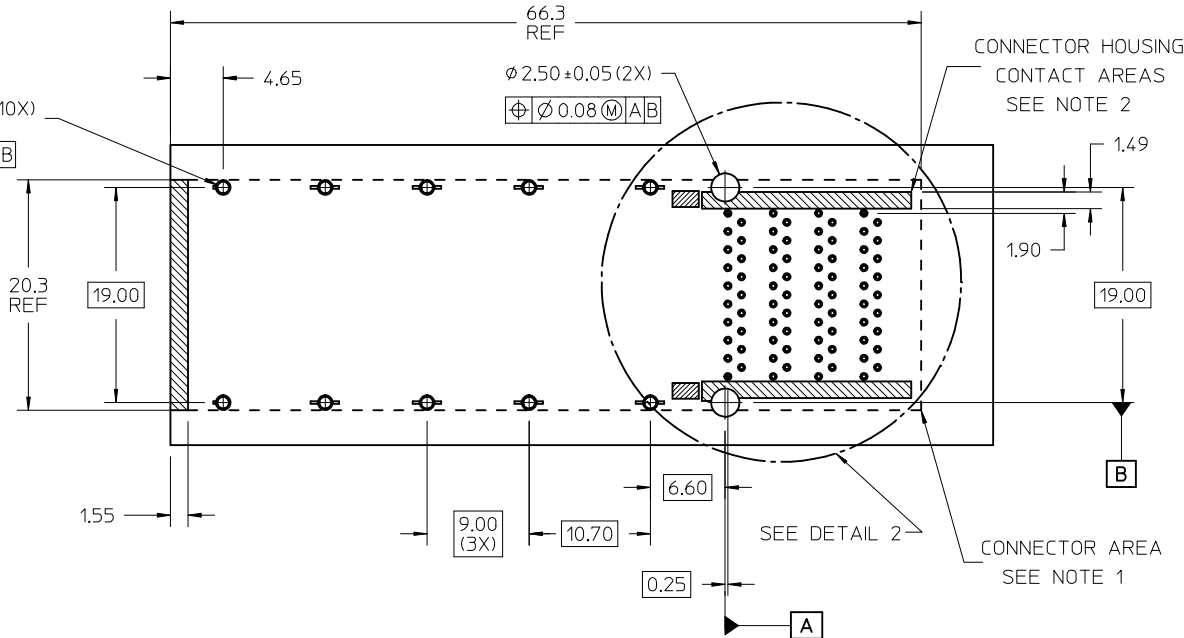
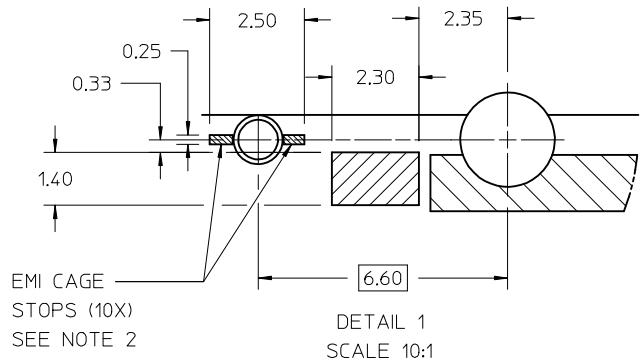

- NOTES:
1. THE ENTIRE AREA UNDER THE CONNECTOR (DASHED LINES) IS TO BE CONSIDERED A KEEP-OUT AREA FOR COMPONENTS.
 2. HATCHED AREAS REPRESENT ZONES ON THE PCB THAT COME IN CONTACT WITH OR BE IN CLOSE PROXIMITY TO THE PLASTIC HOUSING OR THE CONNECTOR CAGE. INDICATED AREAS TO BE CONSIDERED TRACE FREE.
 3. PIN NUMBERS ARE PER THE STANDARD. BOTH PORTS ARE IN THE SAME (UP-UP)MODULE ORIENTATION.
 4. LED KEEP-IN ZONE DEFINES THE PHYSICAL SPACE ALLOWED FOR PLACEMENT OF SMD CHIP STYLE LED PACKAGES INCLUDING SMD MOUNTING PADS. KEEP-IN ZONE EXTENDS VERTICALLY TO 0.8mm ABOVE THE TOP SIDE OF BOARD.
 5. SEE APPLICATION SPEC AS-76870-001 FOR RECOMMENDED DRILL HOLE SIZE.

SEE SHEET 1 EC NO: UCP2014-4000 DRAWN BY: DRWN:HAVERY 2014/03/27 CHKD: APPR:MBANAKIS 2014/03/31	QUALITY SYMBOLS	GENERAL TOLERANCES (UNLESS SPECIFIED)	DIMENSION STYLE MM ONLY	SCALE 3:1	DESIGN UNITS METRIC	THIRD ANGLE PROJECTION
	▽=0	mm INCH	DRAWN BY DATE JGONZALEZ01 2011/08/01	TITLE QSFP 2X1 ASSEMBLY ENHANCED MID SECTION & CLAW FLANGE	MOLEX INCORPORATED	
	▽=0	4 PLACES ± --- ± ---	CHECKED BY DATE KREGNIER 2011/08/01			
	▽=0	3 PLACES ± --- ± ---	APPROVED BY DATE MBANAKIS 2011/12/14	MATERIAL NO.	DOCUMENT NO.	SHEET NO.
	2 PLACES ± 0.13 ± ---	DRAFT WHERE APPLICABLE MUST REMAIN WITHIN DIMENSIONS	SEE SHEET 2	SD-76871-1100	3 OF 3	
	1 PLACE ± 0.25 ± ---		THIS DRAWING CONTAINS INFORMATION THAT IS PROPRIETARY TO MOLEX INCORPORATED AND SHOULD NOT BE USED WITHOUT WRITTEN PERMISSION			

NOTES:

1. MATERIAL:

- CAGE AND SOLDER STRAP: NICKEL SILVER
- GASKET FLANGE: STAINLESS STEEL
- EMI SPRINGS: COPPER ALLOY
- LIGHT PIPES: POLYCARBONATE 94V-0(OPTIONAL)
- GASKET - CORE MATERIAL 94V-0
- CONNECTOR HOUSING: GLASS FILLED THERMOPLASTIC, UL: 94V-0, COLOR: BLACK
- TERMINALS: HIGH PERFORMANCE COPPER ALLOY

2. FINISH:

- CAGE, GASKET FLANGE, AND SOLDER STRAP: UNPLATED
- EMI SPRINGS: 2.5µm NICKEL OVERALL
- TERMINALS: CONTACT AREA: 0.76 µm MIN. HARD GOLD OVER 3.8 µm MIN. NICKEL.
- COMPLIANT TAIL: 0.7 - 1.5 µm MATTE TIN OVER 0.7 - 1.5 µm NICKEL

3. PACKAGING: PRODUCT PACKAGED IN TRAYS AND CARTONS

4. TOP AND SIDE SURFACES TO BE CLASS "B" OR BETTER. ALL REMAINING SURFACES TO BE CLASS "C" OR BETTER WITH THE EXCEPTION OF THE FRONT OF THE MIDSECTION EMI SPRING WHICH IS TO BE A CLASS "A" SURFACE AS DESCRIBED IN THE MOLEX ES-46030-006 COSMETIC SPEC.

5. CONNECTOR MATES WITH PLUG CABLE SERIES 74757 AND 74758

6. DATE CODE LOCATION SHOWN, DATE CODE FORMAT:DDD
DDD= DAY OF THE YEAR Y= YEAR

7. SOLDER STRAP TO BE LASER WELDED IN APPROXIMATE LOCATIONS SHOWN.

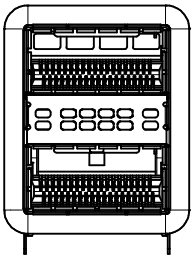
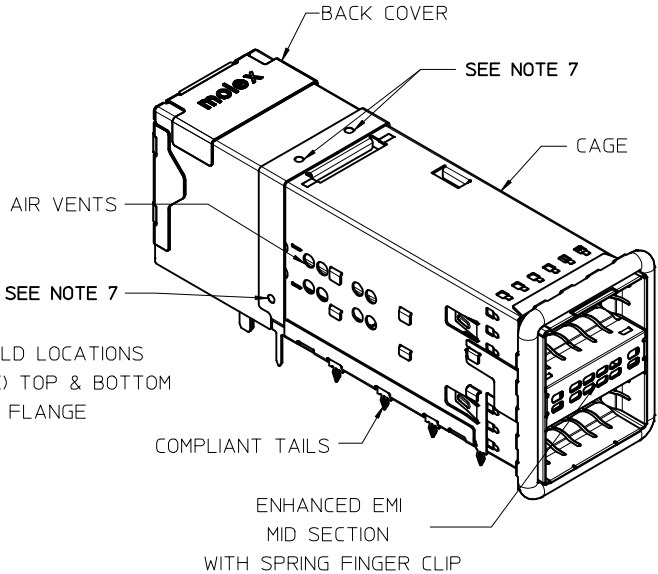
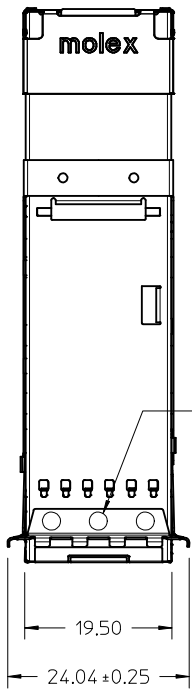

76871-1108 SHOWN W/O GASKET, SEE SHEET 2 FOR OTHER OPTIONS

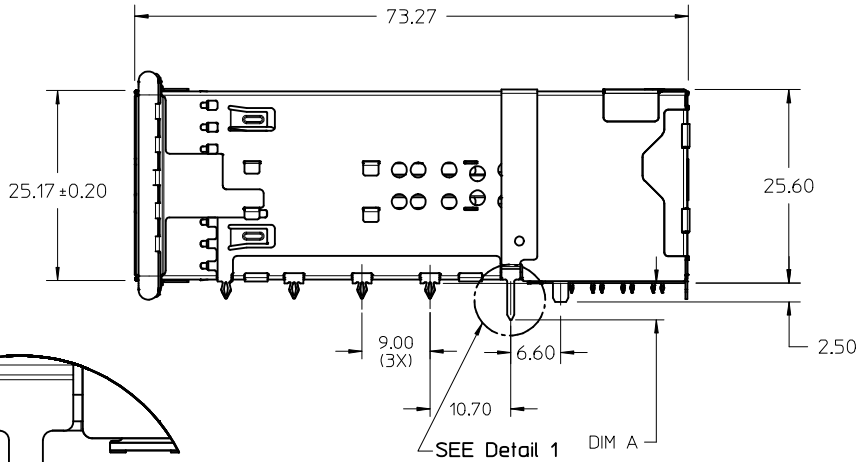

DATE CODE LOCATION
SEE NOTE 6

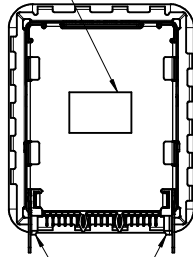

LOCATING PEGS

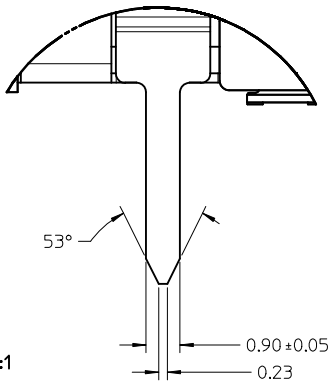

Detail 1
Scale 10:1

UPDATED COSMETIC SPEC NUMBER EC NO: UCP2014-1269 DRWN:HAVERY 2013/08/02 CHKD: APPR:MBANAKIS 2013/10/08 REV 2	QUALITY SYMBOLS ∇=0 ∇=0 ∇=0	GENERAL TOLERANCES (UNLESS SPECIFIED)		DIMENSION STYLE MM ONLY	SCALE 2:1	DESIGN UNITS METRIC	THIRD ANGLE PROJECTION
		4 PLACES ± --- ± --- 3 PLACES ± --- ± --- 2 PLACES ± 0.13 ± --- 1 PLACE ± 0.25 ± --- ANGULAR ± 1/2°	mm INCH	DRAWN BY HAVERY	DATE 2013/01/31	TITLE QSFP 2X1 ASSEMBLY WITH SOLDER STRAP	
		DRAFT WHERE APPLICABLE MUST REMAIN WITHIN DIMENSIONS		APPROVED BY MBANAKIS	DATE 2013/10/08	MOLEX INCORPORATED	
				MATERIAL NO. SEE SHEET 2	DOCUMENT NO. SD-76871-1150	SHEET NO. 1 OF 3	
THIS DRAWING CONTAINS INFORMATION THAT IS PROPRIETARY TO MOLEX INCORPORATED AND SHOULD NOT BE USED WITHOUT WRITTEN PERMISSION							

PART NUMBER	DESCRIPTION	DIM A
76871-1151	LIGHT PIPE UP	4.83
76871-1152	LIGHT PIPE DOWN	4.83
76871-1153	NO LIGHT PIPE	4.83
76871-1154	LIGHT PIPE UP	3.93
76871-1155	LIGHT PIPE DOWN	3.93
76871-1156	NO LIGHT PIPE	3.93
76871-1157	LIGHT PIPE UP	2.90
76871-1158	LIGHT PIPE DOWN	2.90
76871-1159	NO LIGHT PIPE	2.90



76871-1151
76871-1154
76871-1157

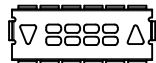

76871-1152
76871-1155
76871-1158

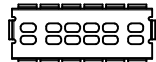

76871-1153
76871-1156
76871-1159

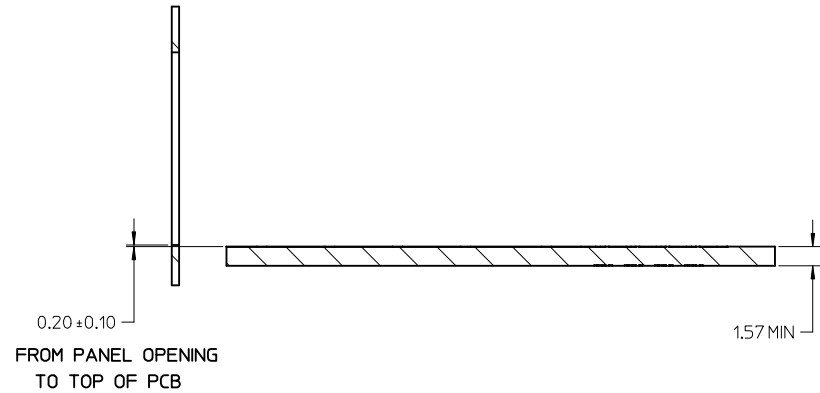
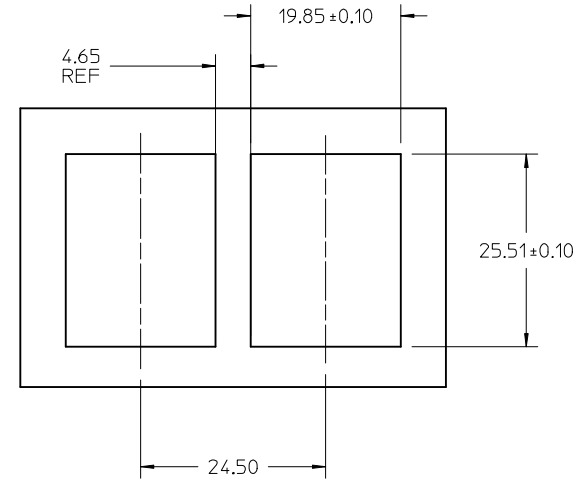

SEE SHEET 1 EC NO: UCP2014-1269 DRW: HAVERY 2013/08/02 CHKD: MBANAKIS APPR: MBANAKIS 2013/10/08	QUALITY SYMBOLS 	GENERAL TOLERANCES (UNLESS SPECIFIED)		DIMENSION STYLE MM ONLY	SCALE 2:1	DESIGN UNITS METRIC	THIRD ANGLE PROJECTION	
		4 PLACES ± --- ± --- 3 PLACES ± --- ± --- 2 PLACES ± 0.13 ± --- 1 PLACE ± 0.25 ± ---	mm INCH	DRAWN BY HAVERY	DATE 2013/01/31	TITLE QSFP 2X1 ASSEMBLY WITH SOLDER STRAP		
2 REV	DESCRIPTION	DRAFT WHERE APPLICABLE MUST REMAIN WITHIN DIMENSIONS		APPROVED BY MBANAKIS	DATE 2013/10/08	MOLEX INCORPORATED		
				MATERIAL NO.	DOCUMENT NO. SD-76871-1150	SHEET NO. 2 OF 3		
				SIZE 	THIS DRAWING CONTAINS INFORMATION THAT IS PROPRIETARY TO MOLEX INCORPORATED AND SHOULD NOT BE USED WITHOUT WRITTEN PERMISSION			

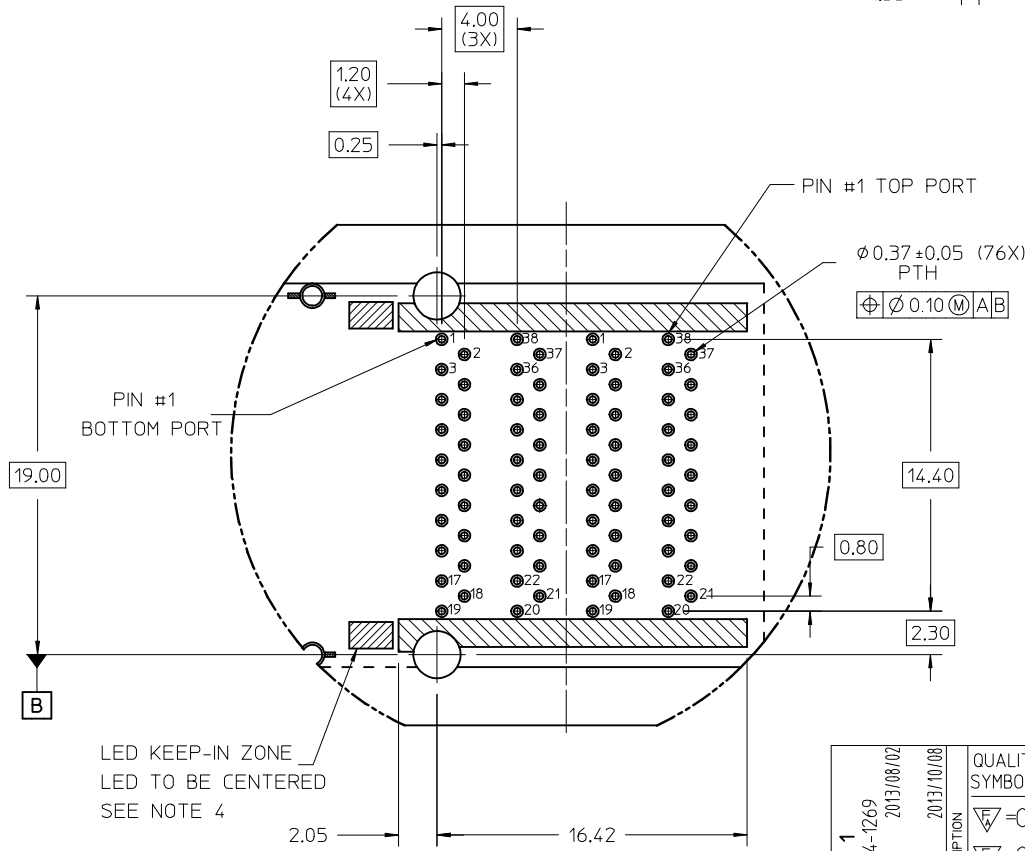
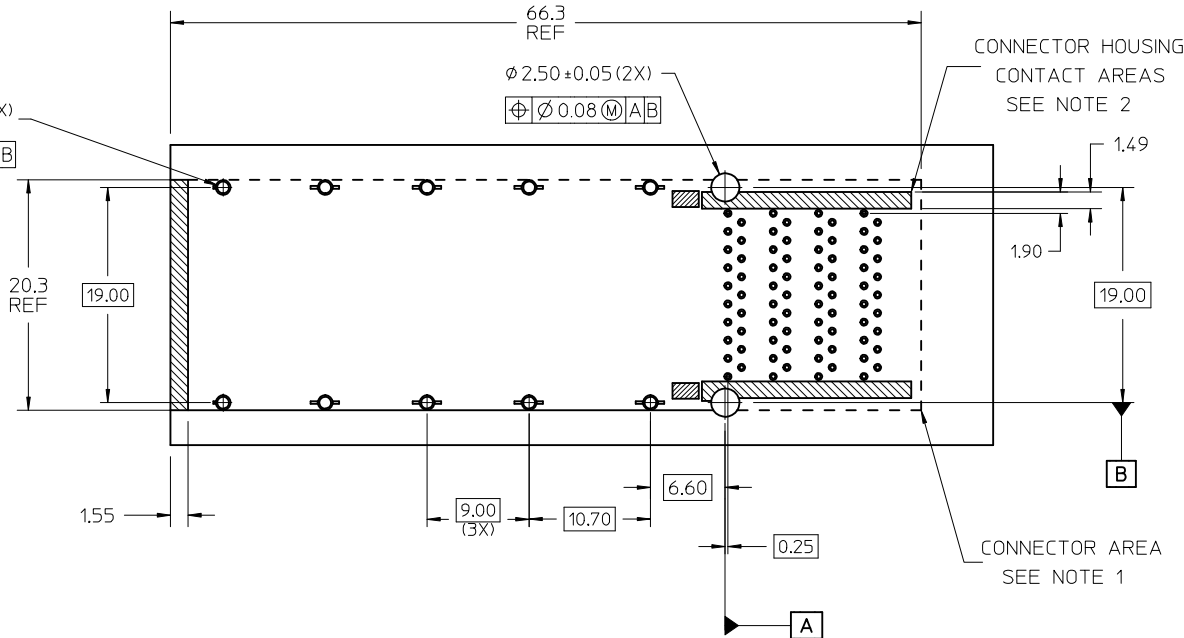
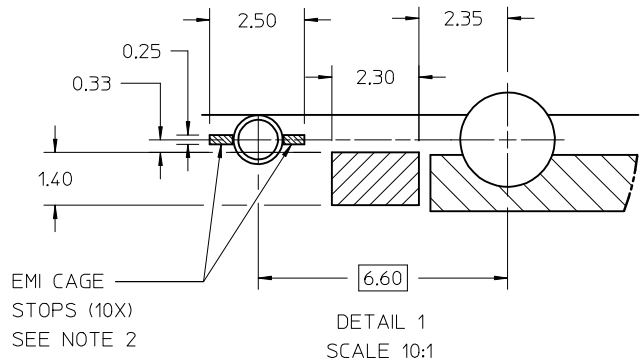

- NOTES:
1. THE ENTIRE AREA UNDER THE CONNECTOR (DASHED LINES) IS TO BE CONSIDERED A KEEP-OUT AREA FOR COMPONENTS.
 2. HATCHED AREAS REPRESENT ZONES ON THE PCB THAT COME IN CONTACT WITH OR BE IN CLOSE PROXIMITY TO THE PLASTIC HOUSING OR THE CONNECTOR CAGE. INDICATED AREAS TO BE CONSIDERED TRACE FREE.
 3. PIN NUMBERS ARE PER THE STANDARD. BOTH PORTS ARE IN THE SAME (UP-UP)MODULE ORIENTATION.
 4. LED KEEP-IN ZONE DEFINES THE PHYSICAL SPACE ALLOWED FOR PLACEMENT OF SMD CHIP STYLE LED PACKAGES INCLUDING SMD MOUNTING PADS. KEEP-IN ZONE EXTENDS VERTICALLY TO 0.8mm ABOVE THE TOP SIDE OF BOARD.
 5. SEE APPLICATION SPEC AS-76870-001 FOR RECOMMENDED DRILL HOLE SIZE.

SEE SHEET 1 EC NO: UCP2014-1269 DRAWN BY: DRWN:HAVERY 2013/08/02 CHKD: APPR:MBANAKIS 2013/10/08 REV: 2	QUALITY SYMBOLS $\nabla = 0$ $\nabla = 0$ $\nabla = 0$	GENERAL TOLERANCES (UNLESS SPECIFIED) <table border="1"> <tr> <th></th> <th>mm</th> <th>INCH</th> </tr> <tr> <td>4 PLACES</td> <td>± 0.13</td> <td>± 0.005</td> </tr> <tr> <td>3 PLACES</td> <td>± 0.25</td> <td>± 0.010</td> </tr> <tr> <td>2 PLACES</td> <td>± 0.50</td> <td>± 0.020</td> </tr> <tr> <td>1 PLACE</td> <td>± 1.00</td> <td>± 0.040</td> </tr> </table>		mm	INCH	4 PLACES	± 0.13	± 0.005	3 PLACES	± 0.25	± 0.010	2 PLACES	± 0.50	± 0.020	1 PLACE	± 1.00	± 0.040	DIMENSION STYLE MM ONLY DRAWN BY: HAVERY DATE: 2013/01/31 CHECKED BY: DATE:	SCALE: 3:1 DESIGN UNITS: METRIC THIRD ANGLE PROJECTION	TITLE: QSFP 2X1 ASSEMBLY WITH SOLDER STRAP
		mm	INCH																	
4 PLACES	± 0.13	± 0.005																		
3 PLACES	± 0.25	± 0.010																		
2 PLACES	± 0.50	± 0.020																		
1 PLACE	± 1.00	± 0.040																		
DRAFT WHERE APPLICABLE MUST REMAIN WITHIN DIMENSIONS	APPROVED BY: MBANAKIS DATE: 2013/10/08 MATERIAL NO.: SEE SHEET 2 SIZE: C	MOLEX INCORPORATED DOCUMENT NO.: SD-76871-1150 SHEET NO.: 3 OF 3	THIS DRAWING CONTAINS INFORMATION THAT IS PROPRIETARY TO MOLEX INCORPORATED AND SHOULD NOT BE USED WITHOUT WRITTEN PERMISSION																	