

Aug.1.2019 Copyright 2019 HIROSE ELECTRIC CO., LTD. All Rights Reserved.  
In case of consideration for using Automotive equipment / device which demand high reliability, kindly contact our sales window correspondents.

COUNT	DESCRIPTION OF REVISIONS	BY	CHKD	DATE	COUNT	DESCRIPTION OF REVISIONS	BY	CHKD	DATE
△				..	△				..
△				..	△				..
△				..	△				..

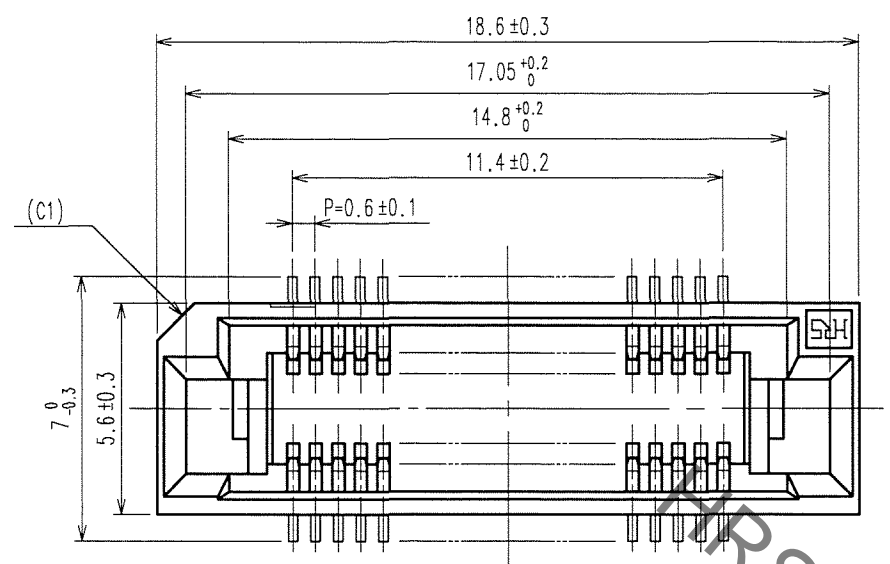

RECOMMENDED LAND PATTERN DIMENSION OF PCB (MOUNTING SIDE) (2:1)

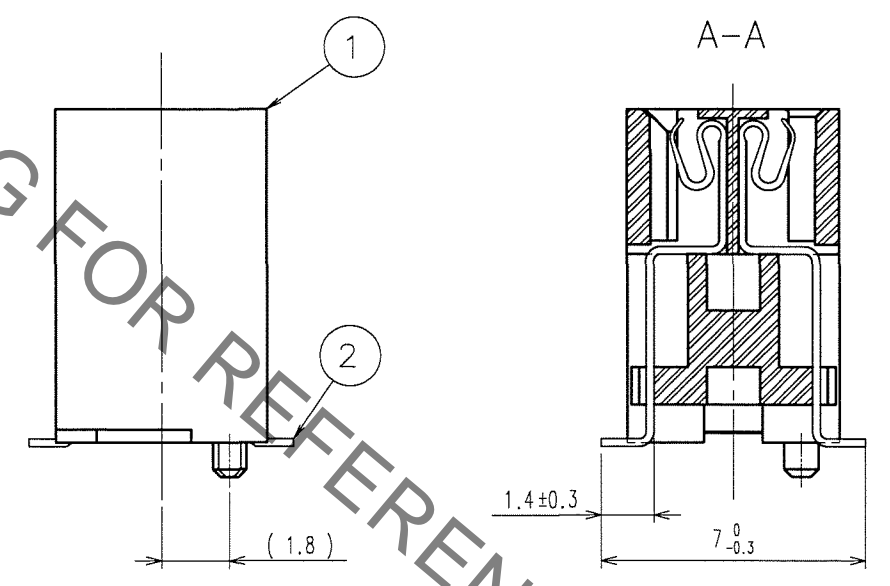
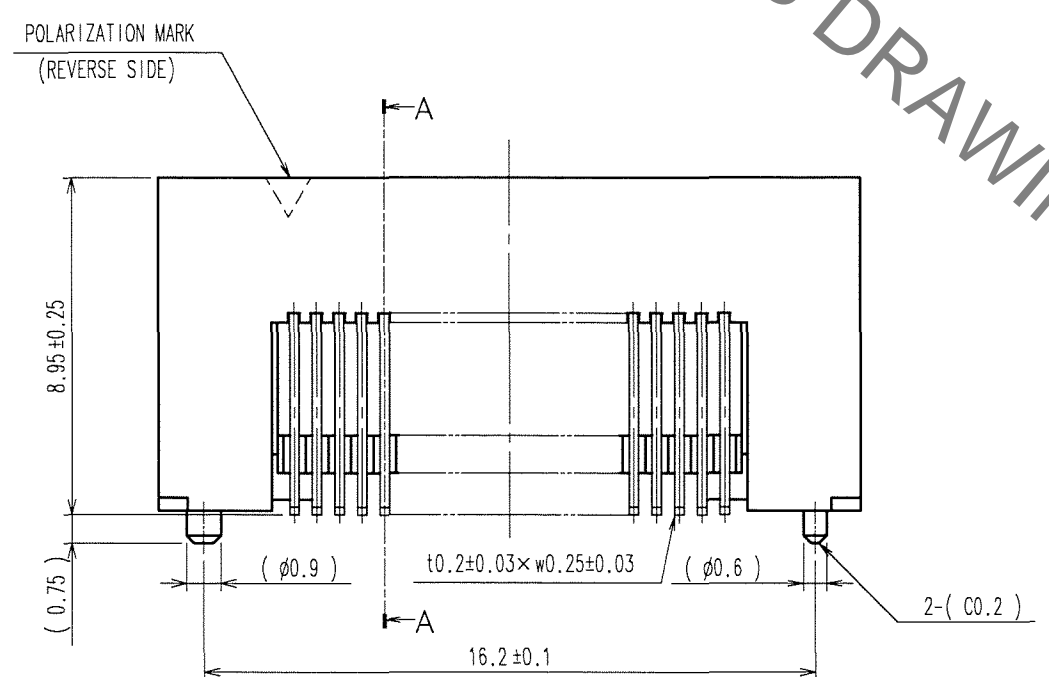
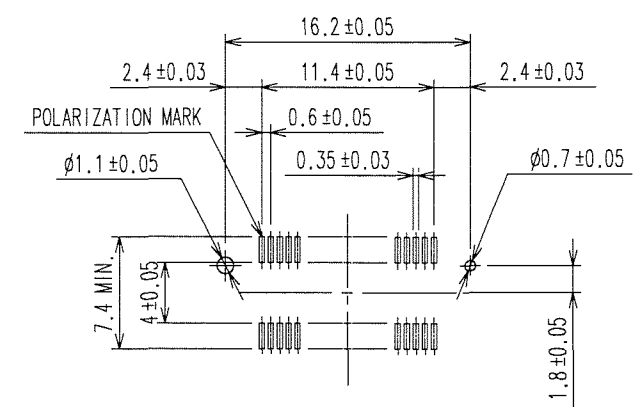

- NOTE 1. LEAD CO-PLANARITY SHALL BE 0.1mm MAX.  
 2. FOR MODIFICATION, ETC., PREVENTIVE HOLE FOR SINK MARK MAY BE ADDED ACCORDING TO CIRCUMSTANCES.  
 3. THE DIMENSIONS IN PARENTHESES ARE FOR REFERENCE.

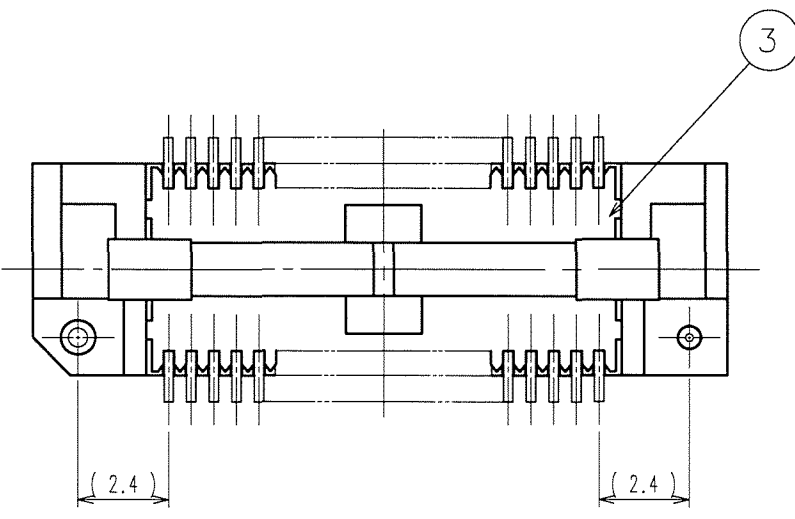

TO
PCK

1, 3	PPS	LIGHT BROWN (UL94V-0)	2	PHOSPHOR BRONZE	CONTACT AREA: GOLD 0.1μm min. LEAD AREA: TIN-PLATING 1μm min. UNDER PLATING: NICKEL 1μm min.
NO.	MATERIAL	FINISH, REMARKS	NO.	MATERIAL	FINISH, REMARKS
CODE NO. (OLD) CL			DRAWN S.KAMIGA 07.04.19	DESIGNED S.KAMIGA 07.04.19	CHECKED H. Okawa 07.04.19
			APPROVED H. Okawa 07.04.19	RELEASED ..	
SCALE 5 : 1	DRAWING NO. EDC3-151170-25		PART NO. FX8C-40S-SV5(71)		
UNITS mm	HIROSE ELECTRIC CO., LTD		CODE NO. CL578-0829-1-71		1/1