

Rectangular Multi-pole Modular Hybrid Connector

CONNECTOR

KN06 Series

MB-0370-3

Mar 2022

RoHS Compliant

JAE has developed the KN06 Series, a rectangular single-engagement lever locking modular connector. This connector series was developed primarily to be used for large-equipment, such as semiconductor-manufacturing equipment and industrial equipment requiring multi-pole wiring.

The KN06 Series connector is capable of housing up to six modular insulators and can mate up to 300 positions in one platform, which significantly reduces the number of connectors necessary during installation compared to conventional use of multiple connectors. Rack and pinion system lever structure allows for little operating force during engagement. The plastic outer shell allows for a lightweight design also contributing to the reduction in workload during mating operations.

Applicable Market

Semiconductor manufacturing, equipment, inspection equipment and large equipment, such as exposure systems, and various industrial equipment requiring multi-pole wiring.

Features

- Multi-pole, single-engagement operation, lever engagement
- Plastic outer shell for weight reduction
- Capable of housing up to six modular insulator blocks for various combinations
(Shared insulator blocks with KN01L Series)
- Lever remains in initiation pre-engagement position while unmated, and provides tactile click when completely mated
- Extendable lever structure for ease of mating and retract for connector compactness
- Built-in mating key provides up to 32 selectable positions of mis-mating prevention options

General Specifications

Insulator	TYPE-1	TYPE-2	TYPE-3	TYPE-4	TYPE-5	TYPE-6
Part Number	KN01L04PF KN01L04SF	KN01L12PG KN01L12SG	KN01L18PK KN01L18SK	KN01L18PKS KN01L18SKS	KN01L42PM KN01L42SM	KN01L50PL KN01L50SL
Contact configuration	#8×4	#12×12	#20×18	#20×18	#22×42 Round Contact	#22×50 Square contact
Rated Voltage	500VDC	500VDC	24VDC	24VDC	24VDC	24VDC
Rated Current (Total)	30A/pin (91.2A)	23A/pin (124.2A)	3A/pin (24.3A)	3A/pin (24.3A)	2A/pin (37.8A)	3A/pin (67.5A)
Dielectric Withstanding Voltage	1500VAC	1500VAC	500VAC	500VAC	500VAC	500VAC
Insulation Resistance	100MΩ (500VDC)	100MΩ (500VDC)	100MΩ (100VDC)	100MΩ (100VDC)	100MΩ (100VDC)	100MΩ (100VDC)
Wiring Method	Crimp termination					
Mating Durability	30 cycles					
Operating Temperature Range	-20°C ~ +105°C					
Standard Certification	UL					

Materials and Finishes

	Component	Materials and Finishes
Shell	Shell	Synthetic resin
Plug	Barrel	Synthetic resin
	Plate (right)	Synthetic resin
	Plate (left)	Synthetic resin
	Lever holder (right)	Synthetic resin
	Lever holder (left)	Synthetic resin
	Lever	Stainless steel
	Spring	Stainless steel
Mating Key	Key	Synthetic resin

Part Configuration

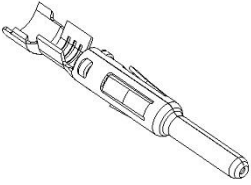
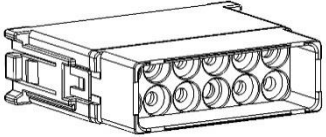
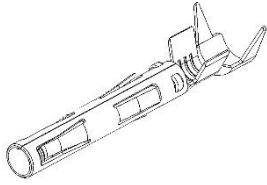
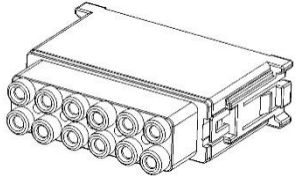
Contact (pin)	Insulator (pin)	Contact (socket)	Insulator (socket)
			

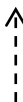
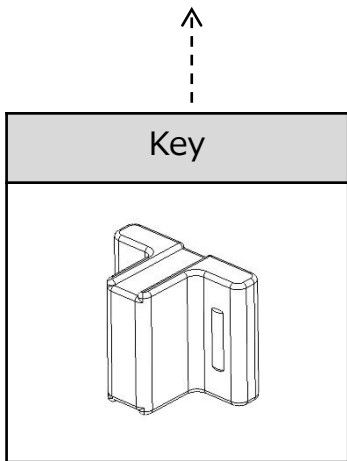
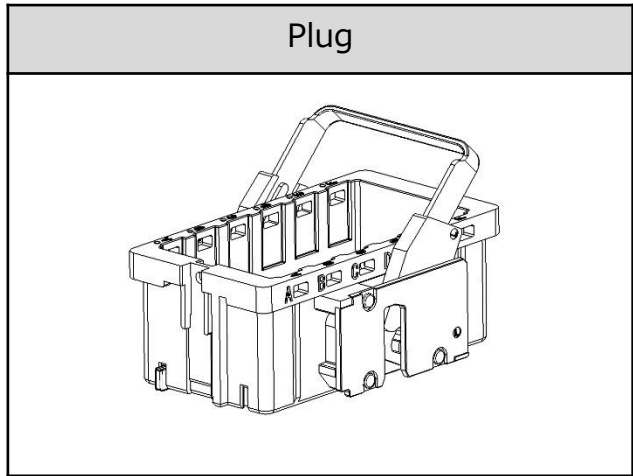
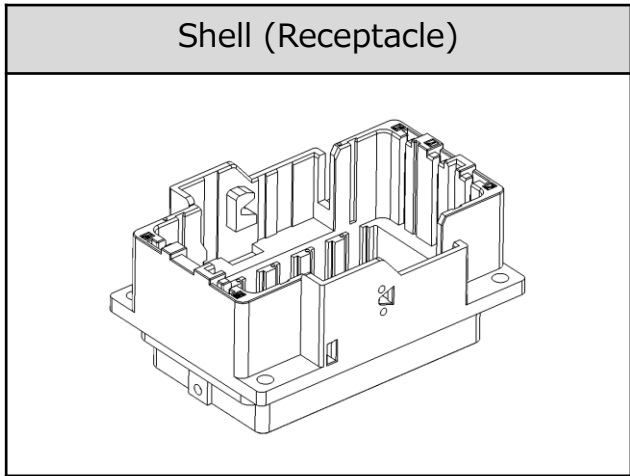
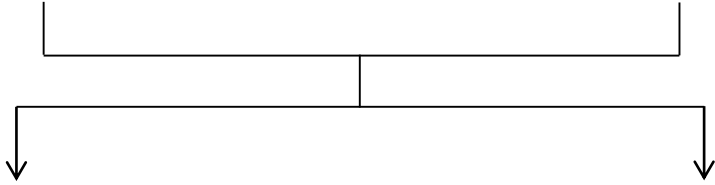

Ordering Information

Shell

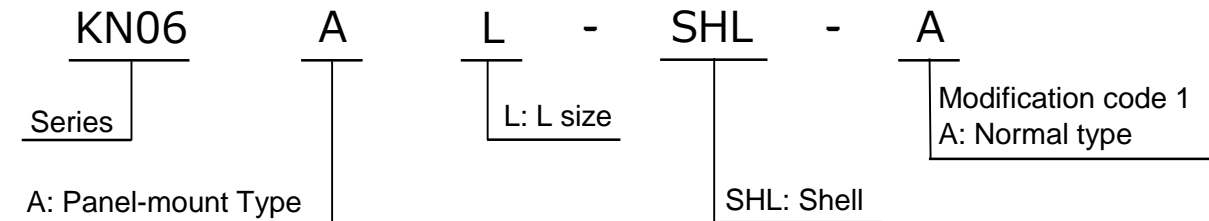

Plug

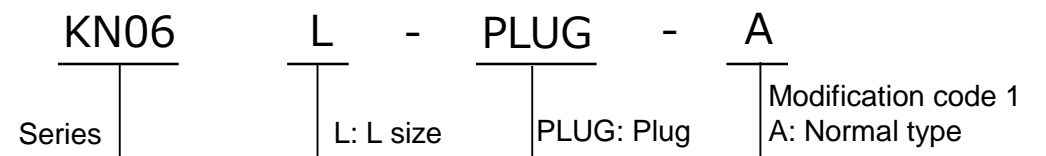

Insulator Module

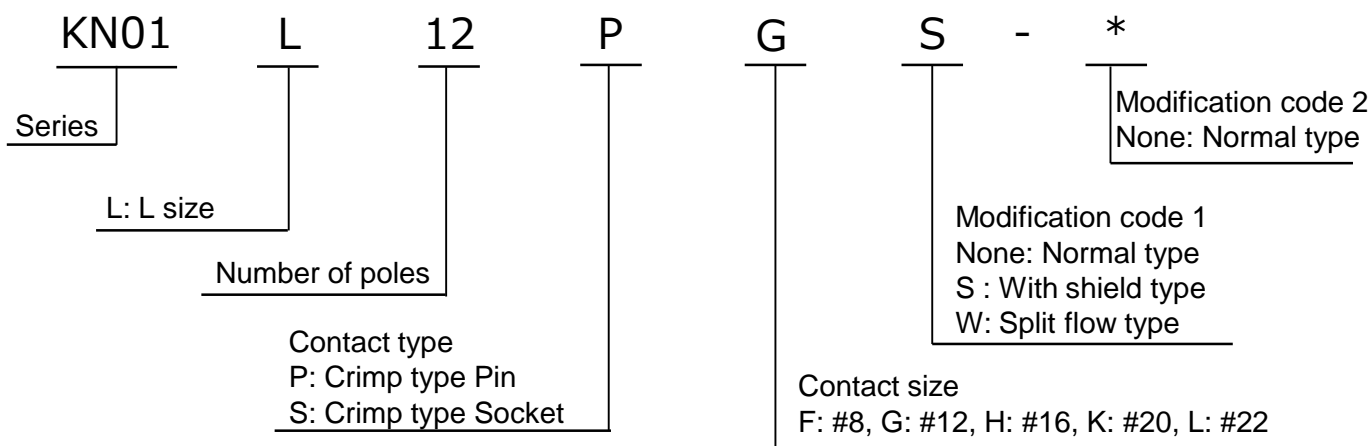

Contact

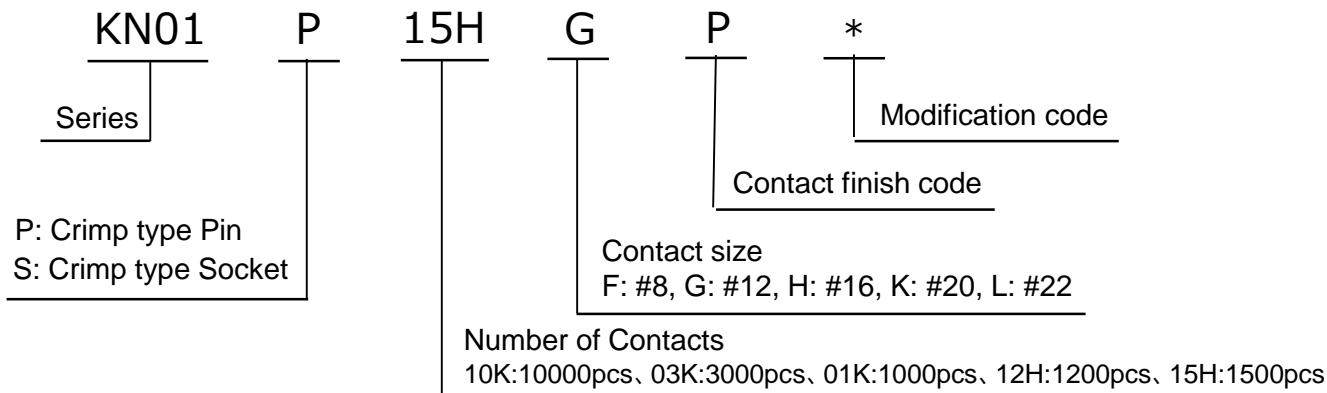

Part Number / Drawing No.

Contact

Type	contact size	Part Number	Drawing No.	Type	contact size	Part Number	Drawing No.		
Pin	# 8	KN01P12HFH1	SJ121831	Socket	# 8	KN01S12HFH1	SJ121832		
	#12	KN01P15HGP1	SJ116958		#12	KN01S15HGP1	SJ116959		
		KN01P15HGP2	SJ116956			KN01S15HGP2	SJ116957		
	#20	KN01P03KKP1	SJ116948			KN01S01KGPW1	SJ116960		
		KN01P03KKP2	SJ116950		#20	KN01S03KKP1	SJ116949		
		KN01P03KKP3	SJ116952			KN01S03KKP2	SJ116951		
	KN01P03KKP4	SJ117065	KN01S03KKP3			SJ116953			
	#22 Round Contact	KN01P10KLH5	SJ121833			KN01S03KKP4	SJ117066		
					#22 Square contact	JN1-22-20P-R-10000	SJ037431	#22 Round Contact	KN01S10KLH5
	#22 Square contact	JN2V-22-20S-10000	SJ116974						#22 Square contact
JN2V-22-26S-10000				SJ116973					

Insulator Module

Type	Part Number	Drawing No.	Number of contacts	Applicable contact size	Remarks
Pin	KN01L04PF	SJ121825	4pin	#8	FMLB mating (FMLB: first to mate, last to break)
	KN01L12PG	SJ117440	12pin	#12	
	KN01L12PG-B	SJ121827	12pin	#12	FMLB mating (FMLB: first to mate, last to break)
	KN01L18PK	SJ117447	18pin	#20	
	KN01L18PKS	SJ117449	18pin	#20	With shielding
	KN01L42PM	SJ121829	42pin	#22	Applicable with round contact
	KN01L50PL	SJ117008	50pin	#22	Applicable with square contact
Socket	KN01L04SF	SJ121824	4pin	#10	FMLB mating (FMLB: first to mate, last to break)
	KN01L12SG	SJ117442	12pin	#12	
	KN01L12SG-B	SJ121828	12pin	#12	FMLB mating (FMLB: first to mate, last to break)
	KN01L12SGW	SJ117451	12pin	#12	
	KN01L18SK	SJ117448	18pin	#20	
	KN01L18SKS	SJ117450	18pin	#20	With shielding
	KN01L42SM	SJ121830	42pin	#22	Applicable with round contact
	KN01L50SL	SJ117009	50pin	#22	Applicable with square contact

Outer Shell

Type	Part Number	Drawing No.	Remarks
Shell	KN06AL-SHL-A	SJ121823	—
Plug	KN06L-PLUG-A	SJ121824	—
Key	KN06-KEY	SJ121835	Mis-mating prevention key

Tools

Crimp Tool

Semi-automatic Crimp Applicator

Contact size	Contact	Applicable tool	Applicable wire	Applicable wire diameter	Tool manual
#8	KN01*12HFH1	350-KN01-10B	AWG10	φ4.0~φ6.8	T703606
#12	KN01*15HGP1	350-KN01-10	AWG12~AWG17	φ3.5~φ4.4	T703551
	KN01*15HGP2			φ2.8~φ3.5	
	KN01S01KGPW1	350-KN01W-10	AWG10~AWG12	φ4.0~φ4.7	T703553
#20	KN01*03KKP1	3502-KN01-2	AWG18~AWG22	φ1.3~φ2.0	T703536
	KN01*03KKP2			φ2.0~φ2.8	
	KN01*03KKP3		AWG22~AWG26	φ1.0~φ1.8	
	KN01*03KKP4			φ1.8~φ2.8	
#22 Round Contact	KN01*10KLH5	3502-KN01-2C	AWG22~AWG24	φ0.9~φ1.5	T703598
#22 Square contact	JN2V-22-20S-10000 JN2V-22-22S-10000 JN2V-22-26S-10000 JN1-22-20P-R-10000 JN1-22-22P-10000 JN1-22-26P-10000	350-JN1-2C 3502-JN1-2C	AWG20~AWG28	φ0.8~φ1.5	T703294 T703413

*The crimping conditions may deviate even within applicable wire range. Please refer to the tool instruction manual for details of the applicable wire range.

Hand Crimp Tool

Common Tool

Contact size	Contact	Applicable tool	Applicable wire	Applicable wire diameter	Tool manual
#20	KN01*03KKP1	CT170-14F-KN01	AWG18~AWG22	φ1.3~φ2.0	T700375
	KN01*03KKP3	CT170-20F-KN01	AWG22~AWG26	φ1.0~φ1.8	T700399

*The crimping conditions may deviate even within applicable wire range. Please refer to the tool instruction manual for details of the applicable wire range.

Hand Crimp Tool

Series Specific Tools

Contact size	Contact	Applicable tool	Applicable wire	Applicable wire diameter	Tool manual
#8	KN01*12HFH1	CT160-23D-KN01	AWG10	φ4.0~φ6.8	T700447
#12	KN01*15HGP1	CT170-21J-KN01	AWG12~AWG14	φ3.5~φ4.4	T700416
	KN01*15HGP2		AWG14~AWG16	φ2.8~φ3.5	
#20	KN01*03KKP1	CT150-19-KN01-20	AWG19~AWG22	φ1.3~φ2.0	T700409
	KN01*03KKP2	CT150-19B-KN01-20	AWG19	φ2.0~φ2.8	T700410
	KN01*03KKP3		AWG22,23,25	φ1.0~φ1.8	
#22 Round Contact	KN01*10KLH5	CT150-19-KN01-22	AWG22~24	φ0.9~φ1.5	T700450
#22 Square Contact	JN2V-22-20S-10000	CT150-2C-JN2V	AWG20	φ1.5 max	T700406
	JN2V-22-22S-10000	CT150-2B-JN2V	AWG22,24,26,28	φ0.8~φ1.3	
	JN2V-22-26S-10000	CT150-2-JN2V	AWG26,28	φ0.8~φ1.0	
	JN1-22-20P-R-10000	CT150-2C-JN2V	AWG20	φ1.5 max	T700406
		CT150-2-JN1-D	AWG20.21		T700253
	JN1-22-22P-10000	CT150-2B-JN2V	AWG22,24	φ0.8~φ1.3	T700406
		CT150-2-JN1-E	AWG21,23,25		T700253
	JN1-22-26P-10000	CT150-2-JN2V	AWG26,28	φ0.8~φ1.0	T700406
CT150-2-JN1-B		AWG26,28	T700238		

*The crimping conditions may deviate even within applicable wire range. Please refer to the tool instruction manual for details of the applicable wire range.

Insulator Extraction Tool

Insulator	Extraction tool	Tool manual
KN01L04*F	WT-KN01-12	T714383
KN01L12*G		
KN01L12*G-B		
KN01L12SGW		
KN01L18*K/KN01L18*KS		
KN01L42*M		

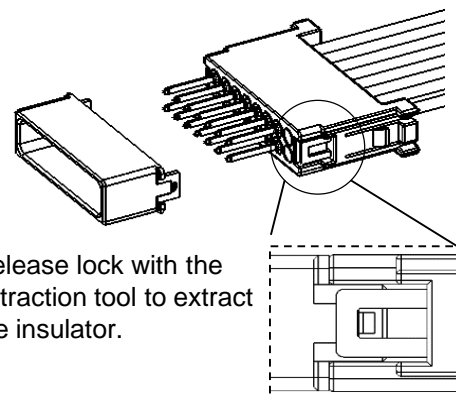

Contact Extraction Tool

Contact size	Extraction tool	Tool manual
#8	ET-KN01-8	T711255
#12	ET-KN01-12	T711209
	ET-KN01W-12	T711210
#20	ET-KN01-20	T711204
#22 Round Contact	ET-KN01-22	T711256
#22 Square Contact	ET-JN1	T711133

Note) When extracting a mis-terminated contact, first unlock and extract insulator from connector with Insulator extraction tool before using the contact extraction tool.

Dimensions

Shell

(mm)

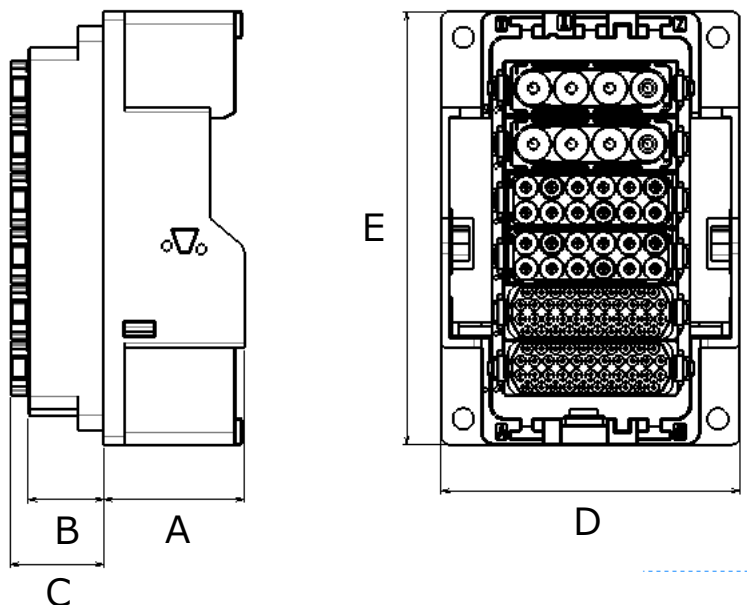

A	33.1
B	17.8
C	21.9
D	70.4
E	102.2

Plug

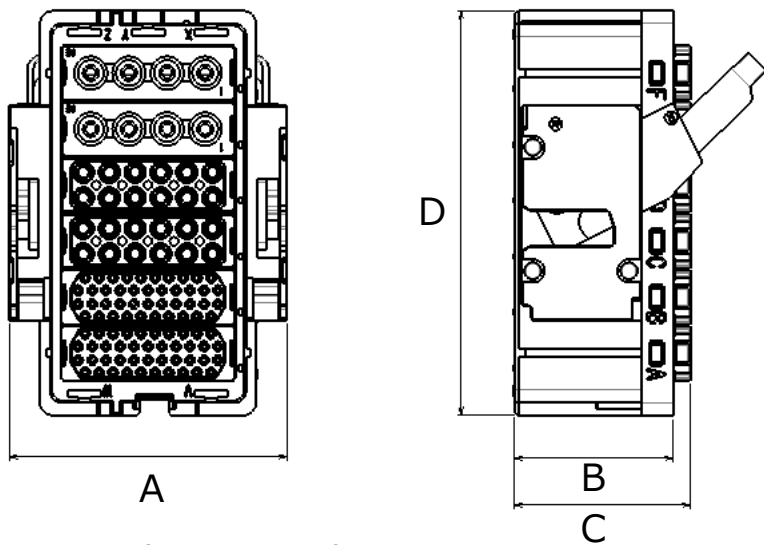

A	65.6
B	37.5
C	41.6
D	95.2

Dimensions when mated

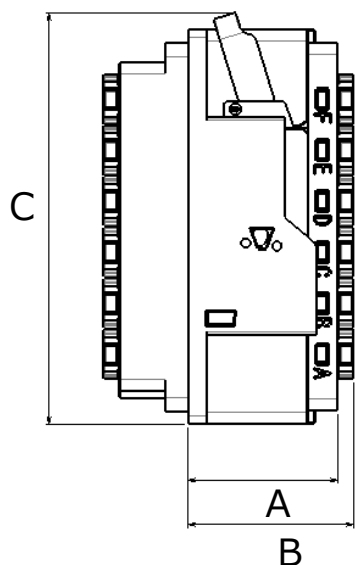

A	38.55
B	42.65
C	106.4

Technical Documents

Specifications	JACS-50134
Handling Instructions	J AHL-50134

Notice:

1. The values specified in this brochure are only for reference. The products and their specifications are subject to change without notice. Contact our sales staff for further information before considering or ordering any of our products. For purchase, a product specification must be agreed upon.

2. Users are requested to provide protection circuits and redundancy circuits to ensure safety of the equipment, and sufficiently review the suitability of JAE's products to the equipment.

3. The products presented in this brochure are designed for the uses recommended below. We strongly suggest you contact our sales staff when considering use of any of the products in any other way than the recommended applications or for a specific use that requires an extremely high reliability.

(1) Applications that require consultation:

(i) Please contact us if you are considering use involving a quality assurance program that you specify or that is peculiar to the industry, such as:

Automotive electrical components, train control, telecommunications devices (mainline), traffic light control, electric power, combustion control, fire prevention or security systems, disaster prevention equipment, etc.

(ii) We may separately give you our support with a quality assurance program that you specify, when you think of a use such as :

Aviation or space equipment, submarine repeaters, nuclear power control systems, medical equipment for life support, etc.

(2) Recommended applications include:

Computers, office appliances, telecommunications devices (terminals, mobile units), measuring equipment, audiovisual equipment, home electric appliances, factory automation equipment, etc.

Japan Aviation Electronics Industry, Limited

* The specifications in this brochure are subject to change without notice. Please contact JAE for information.