

REFERENCE:

PERFORMANCE REQUIREMENTS AT DRY AS MOLDED:

1. SHEET METAL THICKNESS RANGE: 0.60mm - 5.75mm
2. CIRCULAR HOLE SIZE: 6.5 +/- 0.4mm
3. APPLICABLE HEX HOLE: 6.35mm +/- 0.25mm

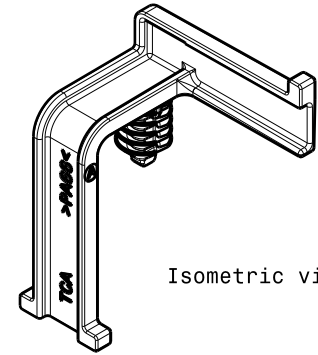
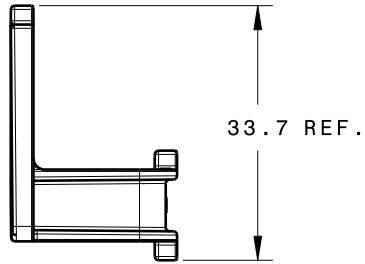

Isometric view

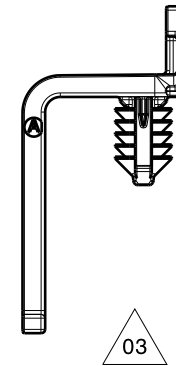
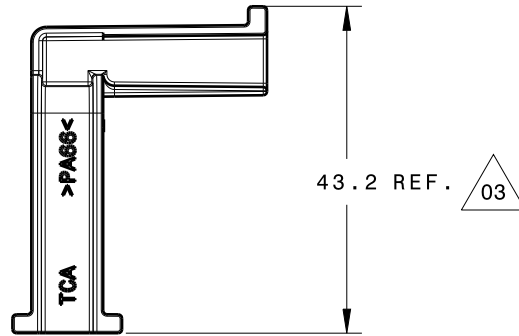
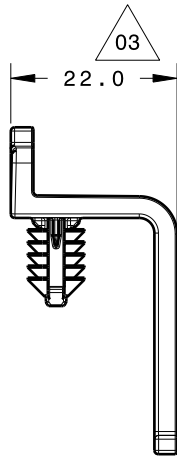

INVENTORS

HellermannTyton

ALL PROPRIETARY RIGHTS IN THE SUBJECT MATTER SHOWN ON THIS DRAWING ARE EXCLUSIVE PROPERTY OF HELLERMANN TYTON

name	date	city state
S. ADAMS	5/8/12	MENOMONEE FALLS, WI.

REVISIONS	DR level	03
	AW by	KVH
	IN date	10/5/12
	GN ECN #	012167
	part level	A

DIMENSIONS	TOLERANCES
	.XXXX = ± 0.25
	.XXX = ± 0.50
	.XX = ± 1.00
	.X = ± 2.00
∠ = ± 1.00	
unless otherwise specified	
units	millimeters

PART	number	SOC13FT6LGL	phase	PRODUCTION
	name	STEPPED TAPE CLIP WITH 6.5MM FIR TREE		
	material	PA66HIRHS COLOR: GRAY		

DRAWING	FORMAT	AH	CAD	CATIA V5	SCALE	1:1
	VERSION	J	previous drawing number			
	A- SIZE (landscape)_N01					
	drawn	S. ADAMS	checked	K. VAN HULST	approved	
		5/8/12		5/8/12		
	type	CUSTOMER	sheet 1 of 1			
number	12-0325-001-CSU					