

**FineAdjust
Applicator**

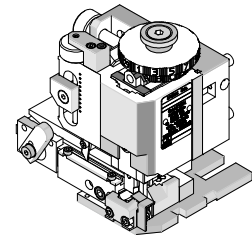

**Application Tooling
Specification Sheet**



Order No. 63902-9900

FEATURES

- Directly adapts to most automatic wire processing machines
- Quick punch removal with the push of a button for fast and easy tooling change
- Applicator designed to industry standard mounting and shut height 135.80mm (5.346")
- Quick set-up time; plus the crimp height, track and feed adjustments can be set without removing the applicator from the press
- Fine adjustment allows users to achieve target with little effort by adjusting in increments of .015mm (.0006") for conductor crimp height and .063mm (.0025") for insulation height
- Independent adjustment rings allow users to quickly adjust the conductor or insulation crimp height without affecting each other

SCOPE

Products: Solder Right In-Board Terminals, 22-24 AWG.

Terminal Series No.	Terminal Order No.	Wire Size		◆Insulation Diameter UL1007 Wire is Recommended				Strip Length	
				IPC/WHMA-A620 (1)		Terminal			
		AWG	mm ²	mm	In.	mm	In.	mm	In.
172677	172677-0100	22-24	---	1.45-1.65	.057-.067	1.45-1.65	.057-.067	5.10-5.40	.200-.212

(1) To achieve optimum IPC-A620 Class 2 insulation crimps, use this insulation OD.
Note: Oiler (Order No. 63801-7240) is required to crimp these terminals. See Fine Adjust Manual (Order no. 63800-4900).

DEFINITION OF TERMS

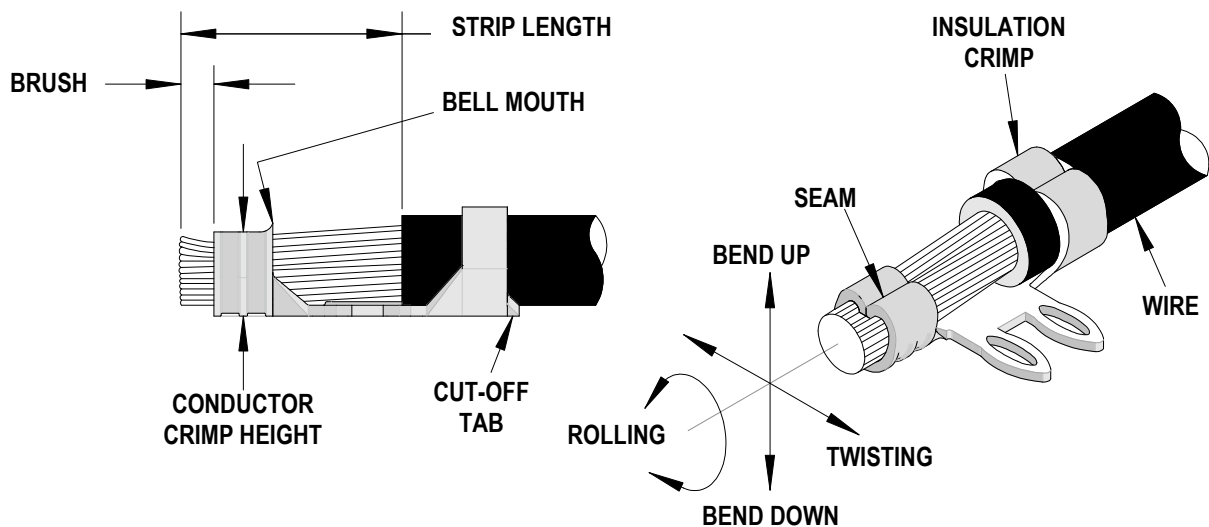

CRIMP SPECIFICATION

Terminal Series No.	Bell mouth		Cut-off Tab Maximum		Conductor Brush	
	mm	In.	mm	In.	mm	In.
172677	0.20-0.40	.008-.016	0.50	.020	0.00-0.70	.000-.027

Terminal Series No.	Bend up Degree (Max)	Bend down Degree (Max)	Twist Degree (Max)	Roll Degree (Max)	Punch Width (Ref)				Seam Seam shall not be open and no wire allowed out of the crimping area
					Conductor		Insulation		
					mm	In	mm	In	
172677	3	3	5	5	1.40	.055	1.90	.075	

After crimping, the conductor profile should measure the following.

Terminal Series No.	Wire Size		Conductor				Pull Force Minimum	
			Crimp Height		Crimp Width (Ref.)		▶ See Tool Qualification Notes	
	AWG	mm ²	mm	In.	mm	In.	N	Lb.
172677	22	---	0.74-0.80	.029-.031	1.40-1.48	.055-.058	20.0	4.50
	24	---	0.68-0.74	.027-.029	1.40-1.48	.055-.058	13.4	3.00

Terminal Series No.	Wire Size		Insulation			
			Crimp Height (Ref.)		Crimp Width (Ref.)	
	AWG	mm ²	mm	In.	mm	In.
172677	22	---	1.70	.067	1.90	.075
	24	---	1.65	.064	1.90	.075

▶ **Tool Qualification Notes:**

The above specifications are guidelines to an optimum crimp.

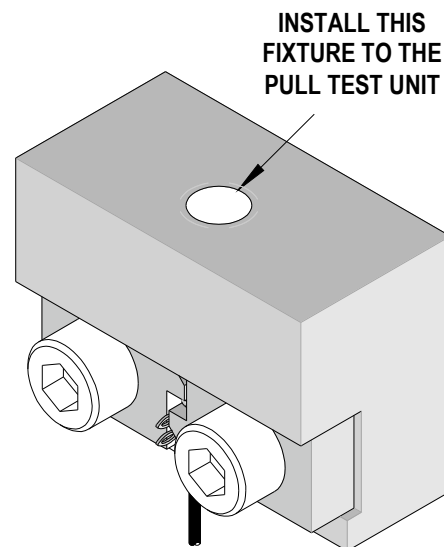
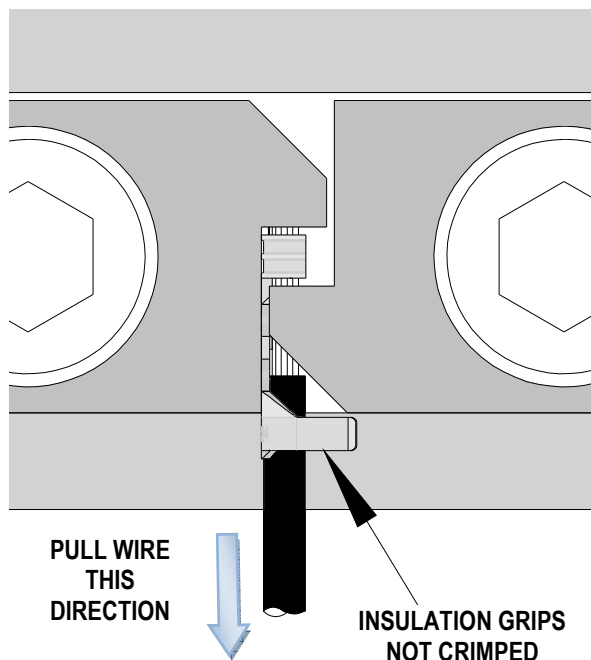

Figure 1

PARTS LIST

FineAdjust Applicator 63902-9900				
Item	Order No	Engineering No.	Description	Quantity
Perishable Tooling				
	63902-9970	63902-9970	Tool Kit (All "Y" Items)	REF
1	63457-1401	63457-1401	Conductor Punch	1 Y
2	63445-1445	63445-1445	Conductor Anvil	1 Y
3	63454-1901	63454-1901	Insulation Punch	1 Y
4	63445-1930	63445-1930	Insulation Anvil	1 Y
5	63456-4001	63456-4001	Anvil	1 Y
6	63443-0002	63443-0002	Front Cut-Off Plunger	1 Y
7	63443-0012	63443-0012	Front Plunger Retainer	1 Y
Other Components				
8	11-18-4083	60707-8	Feed Guide	1
9	11-24-1067	4996-4	Cut-Off Plunger Spring	1
10	63443-0009	63443-0009	Front Scrap Chute	1
11	63443-0024	63443-0024	Key	1
12	63443-2802	63443-2802	Front Plunger Striker	1
13	63443-2917	63443-2917	Wire Hold-Down Plunger	1
14	63443-6115	63443-6115	Rear Cover	1
15	63600-1057	63600-1057	Compression Spring	1
16	63903-0151	63903-0151	Anvil Mount	1
17	63903-0152	63903-0152	Wire Stop	1
18	63903-0153	63903-0153	Terminal Stripper	1
Frame				
19	63800-4901	63800-4901	Top	1
20	63801-3281	63801-3281	Base	1
21	63801-4650	63801-4650	Track	1
22	63860-2015	63860-2015	Drag Frame	1
Hardware				
23	N/A	N/A	M3 by 6 Long SHCS	2**
24	N/A	N/A	M3 by 6 Long FHCS	1**
25	N/A	N/A	M4 by 6 Long SHCS	3**
26	N/A	N/A	M4 by 12 Long BHCS	2**
27	N/A	N/A	M4 by 50 Long SHCS	2**
28	N/A	N/A	#10-32 by 3/8" Long Flat Point SSS	1**
29	N/A	N/A	#10-32 Hex Jam Nut	1**
** Available from an industrial supply company such as MSC (1-800-645-7270).				

Assembly Drawing

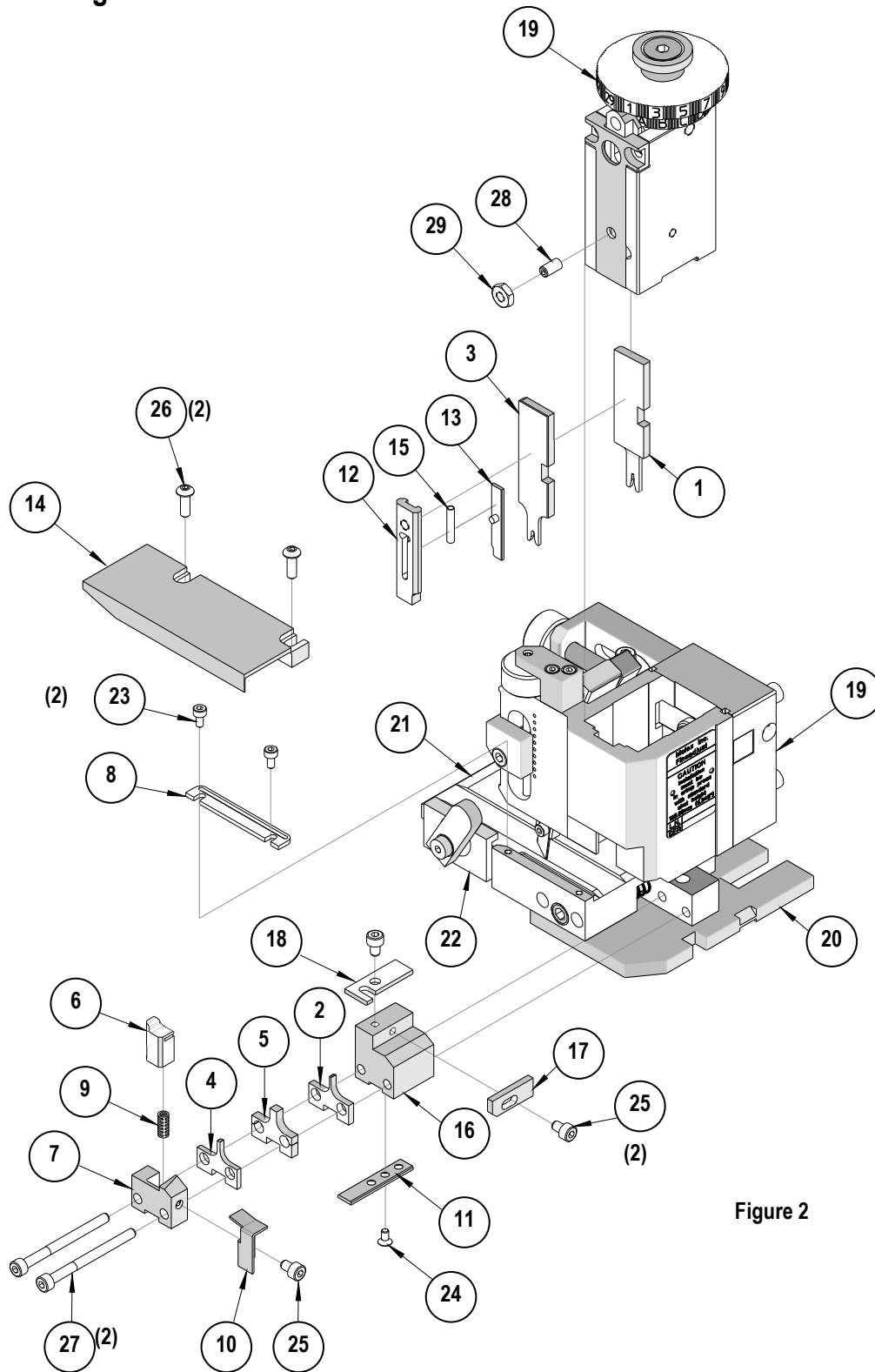

Figure 2

NOTES

1. Molex recommends an extra perishable tooling kit be maintained at your facility.
2. Verify tooling alignment by manually cycling the press and Applicator before crimping under power. Check that all screws are tight.
3. Slugs, Terminals, Dirt and Oil should be kept clear of work area.
4. Wear safety glasses at all times.
5. For recommended maintenance refer to the FineAdjust Manual.

CAUTION: This applicator should only be used in a press with a shut height of 135.8mm (5.346"). Tooling damage could result at a lower setting.

CAUTION: To prevent injury never operate this Applicator without the guards supplied with the press or wire-processing machine in place. Reference the press or wire processing manufacturer's instruction manual.

CAUTION: Molex crimp specifications are valid only when used with Molex terminals, applicators and tooling.

Visit our Web site at <http://www.molex.com>