

LOC		DIST		REVISIONS			
P	LTR	DESCRIPTION	DATE	DMN	APVD		
E	REV PER ECO	10-009372	6-22-10	CT	DM		

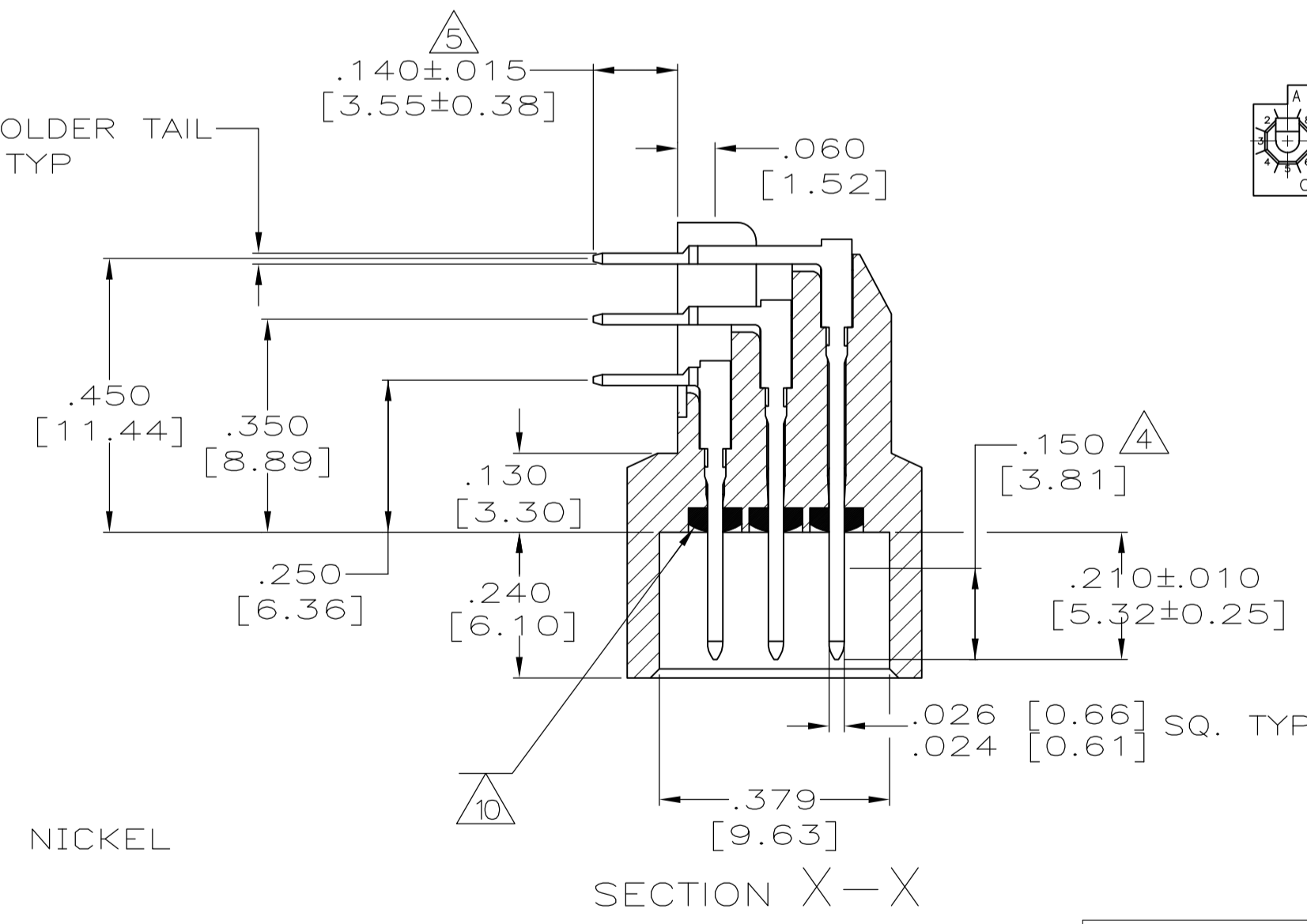
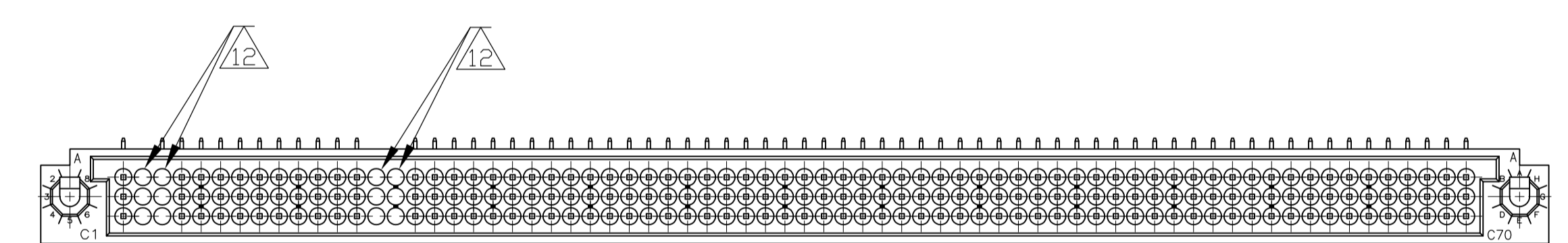
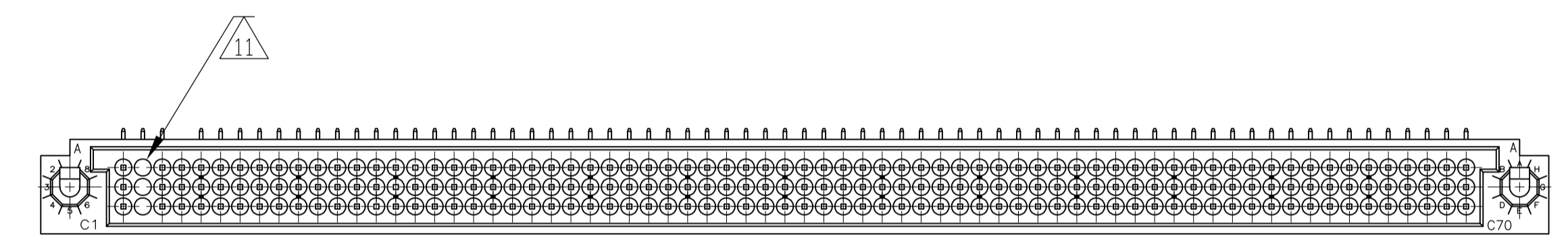
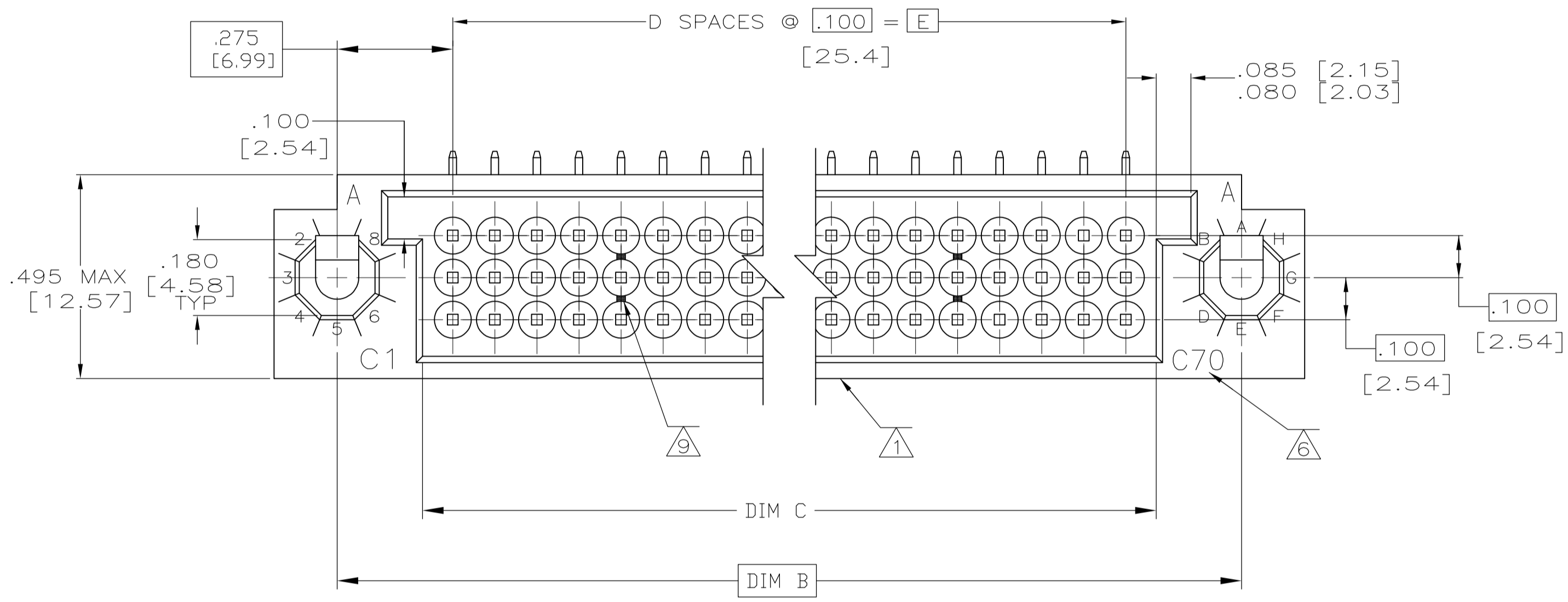
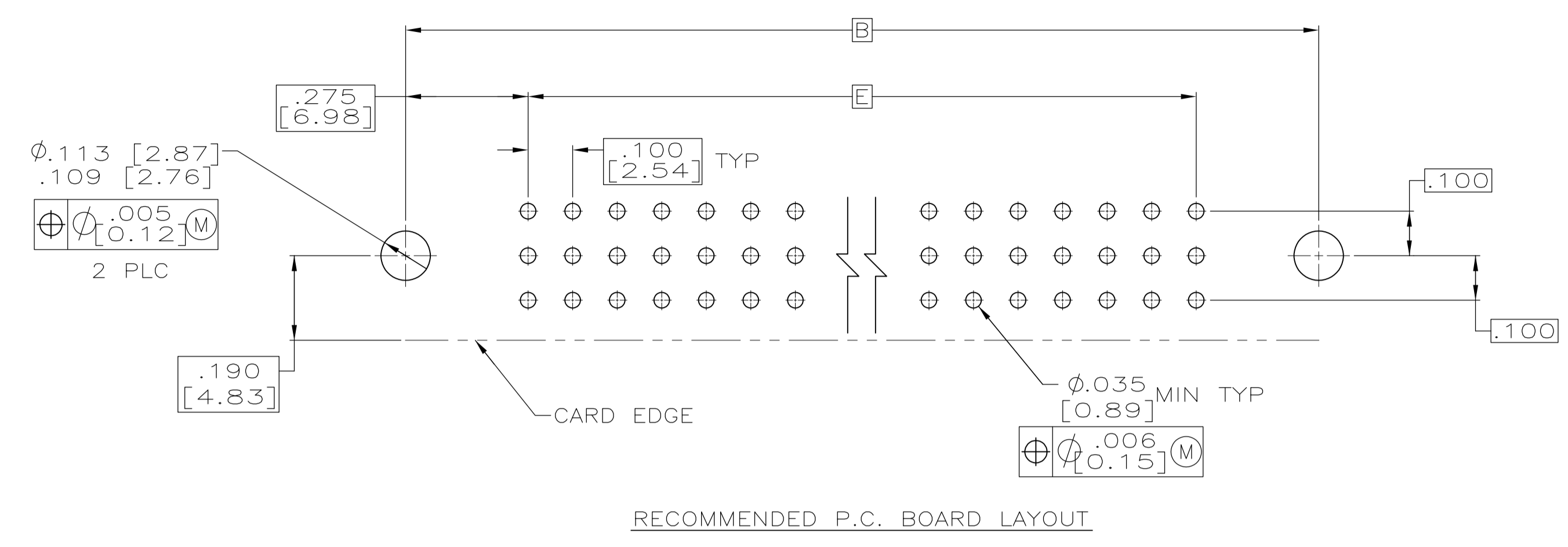
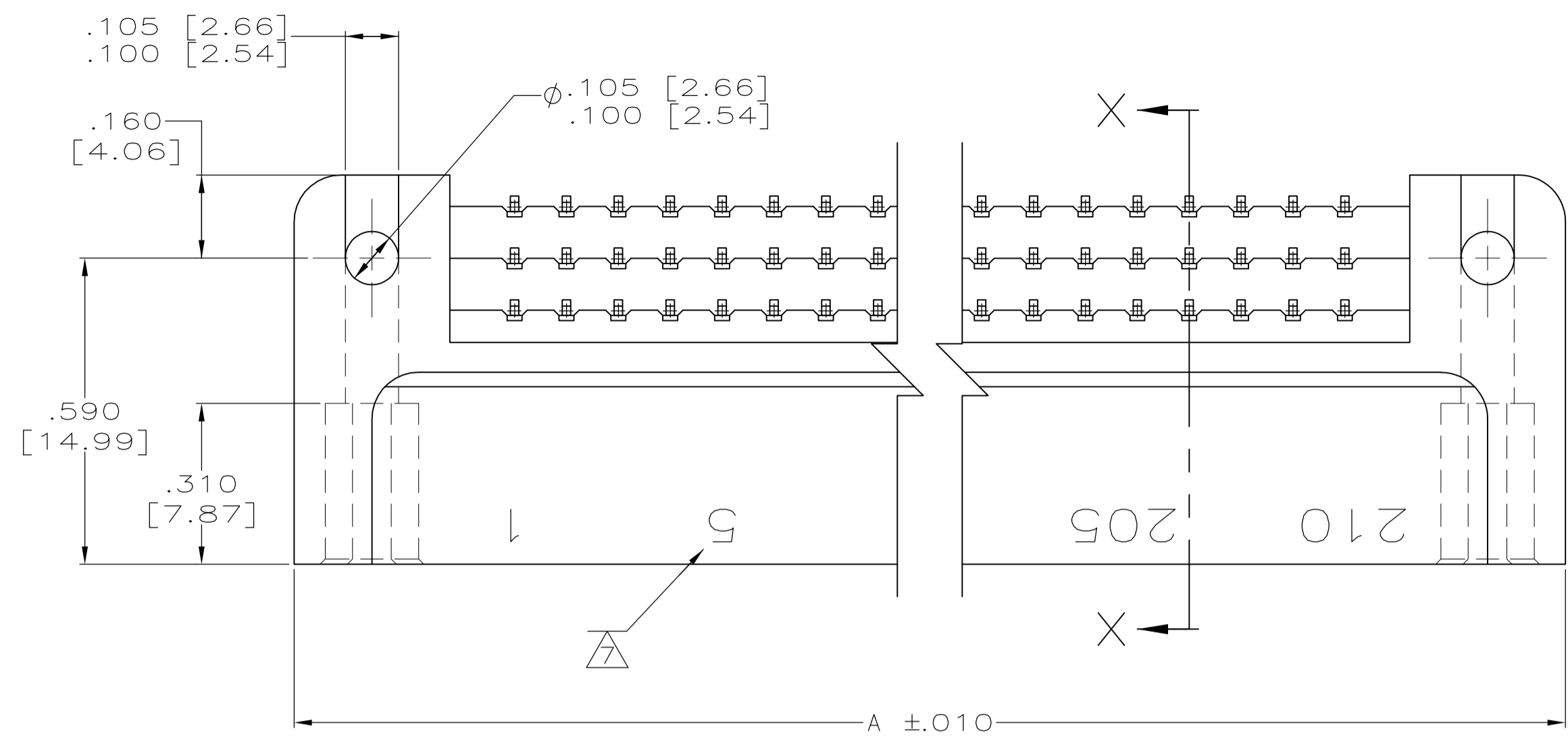

- △ CUSTOMER CAGE CODE AND PART NO. (PER TABLE), 00779, DATE CODE, TE PART NO. AND AMP MARKED THIS SIDE.
- △ HOUSING MAT'L: POLYPHENYLENE SULFIDE, GST-40F PER MIL-M-24519.
- △ CONTACT MAT'L: BRASS PER QQ-B-626.
- △ CONTACT FINISH: .000050" [0.00127] GOLD OVER .000050" [0.00127] NICKEL IN CONTACT AREA.
- △ CONTACT FINISH: .000100" [0.00254] TIN-LEAD OVER .000050" [0.00127] NICKEL
- △ LETTERS INDICATING OUTSIDE ROWS AND NUMBERS INDICATING END CAVITIES (ROW C ONLY) MARKED THIS SURFACE.
- △ NUMBERS INDICATING EVERY FIVE CAVITIES MARKED, BOTH SIDES.
- 8. MEETS ALL REQUIREMENTS OF MIL-C-55302.
- △ LINES INDICATING EVERY FIVE CAVITIES MARKED ON MATING FACE, EXCEPT END CAVITIES, STARTING AT POSN. #1.
- △ EPOXY SEALANT TO PREVENT WICKING OF FLUXES AND CONFORMAL COATING INTO THE CONTACT ENGAGEMENT AREA.
- △ CONTACT REMOVED FROM POSITION A2, B2 & C2 FOR 1996168-1 ONLY. EMPTY CAVITIES ARE SEALED WITH EPOXY.
- △ CONTACT REMOVED FROM POSITION A2, B2, C2, A3, B3, C3, A14, B14, C14, A15, B15 & C15 FOR 1996168-2 ONLY. EMPTY CAVITIES ARE SEALED WITH EPOXY.

REMARKS	CUSTOMER P/N	E	D	C	B	A	POSN.	PART NO.
△12	04804-4A48273H02	6.900 [175.26]	69	7.044 [178.91]	7.450 [189.23]	7.750 [196.85]	198	1996168-2
△11	04804-4A48273H01	6.900 [175.26]	69	7.044 [178.91]	7.450 [189.23]	7.750 [196.85]	207	1996168-1

THIS DRAWING IS A CONTROLLED DOCUMENT.

DIMENSIONS: INCHES [mm]	TOLERANCES UNLESS OTHERWISE SPECIFIED:	DIN C.C.THOMAS 2-6-08	APVD J.WEAVER 2-6-08	NAME J.WEAVER	TYCO ELECTRONICS CORPORATION Harrisburg, PA 17105-3608
0 PLC ± -	1 PLC ± -	2 PLC ± -	3 PLC ± -	4 PLC ± .005 [0.13]	ANGLES ± -
MATERIAL -	FINISH -	WEIGHT -	SIZE A1	CAGE CODE 00779	DRAWING NO. 1996168
CUSTOMER DRAWING		SCALE 4:1	SHEET 1 OF 1	REV E	