

| PART NUMBER | REVISION | DESCRIPTION                     | FEED TYPE |
|-------------|----------|---------------------------------|-----------|
| 2150268-2   | C        | FINE CRIMP HEIGHT ADJUST        | PNEUMATIC |
| 7-2150268-2 | C        | PNEUMATIC AND CRIMP TOOLING KIT | PNEUMATIC |
| 7-2150268-7 | A        | CRIMP TOOLING KIT               | -         |

ATLANTIC VERSION TERMINATOR INTERFACE ADAPTER

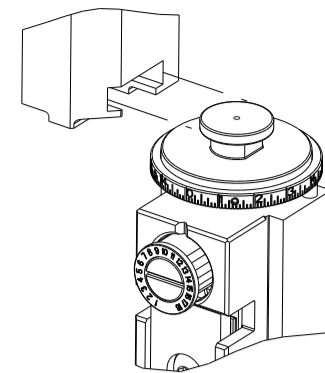

| APPLICATOR DATA                |                |      |
|--------------------------------|----------------|------|
| CRIMP                          | SIZE           | TYPE |
| WIRE                           | 6.02 mm [.237] | D    |
| INSUL                          | -              | -    |
| APPL INSTRUCTIONS<br>408-35043 |                |      |

| TERMINAL DATA: TE TERMINAL                         |   | TE CRIMP SPEC |
|--|---|---------------|
| TERMINAL NAME: RECPT, ULTRA-FAST FLAG, .187 SERIES |   |               |
| WIRE STRIP LENGTH<br>7.51-8.33 mm [.296-.328 IN]   | INSULATION DIAMETER RANGE<br>Ø .185 MAX |               |
| TERMINAL APPLICATION SPECIFICATION<br>114-2123     |   |               |
| TERMINALS APPLIED $\triangle 4$                    |   |               |
| TE TERMINAL  | TE TERMINAL                             | TE TERMINAL   |
| 3-520338-2   | 6-520338-2                              | 9-520340-2    |
| 5-520338-2   | 3-520340-2                              |               |

| WIRE SIZE | CRIMP HEIGHT mm [INCH]      | CRIMP HEIGHT REFERENCE SETTING | Ø SOLDER        |
|-----------|-----------------------------|--------------------------------|-----------------|
| 14        | 1.905+/-0.05 [.075+/- .002] | 4.8                            | .19 in [4.83mm] |
| 16        | 1.778+/-0.05 [.070+/- .002] | 6.0                            | .19 in [4.83mm] |

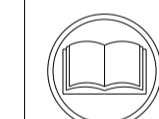

- $\triangle 1$  RECOMMENDED SPARE PARTS
- $\triangle 2$  REFER TO SUPPLIED INSTRUCTION SHEET FOR CLEANING, LUBRICATION AND STORAGE OF APPLICATOR.
- $\triangle 3$  CRIMP HEIGHT REFERENCE SETTING WAS THE SETTING USED WHEN THE APPLICATOR WAS QUALIFIED AT THE FACTORY. ADJUSTMENT MAY BE NECESSARY WHEN RUNNING APPLICATOR IN THE FIELD.
- $\triangle 4$  TERMINAL PITCH NOT COMPATIBLE WITH MECHANICAL FEED.
- $\triangle 5$  TO CHECK CRIMP HEIGHT, CRIMP SOLDER (Ø .19 IN [4.83mm] 60/40 SOLID CORE) AND MEASURE AT CENTER OF SLUG.

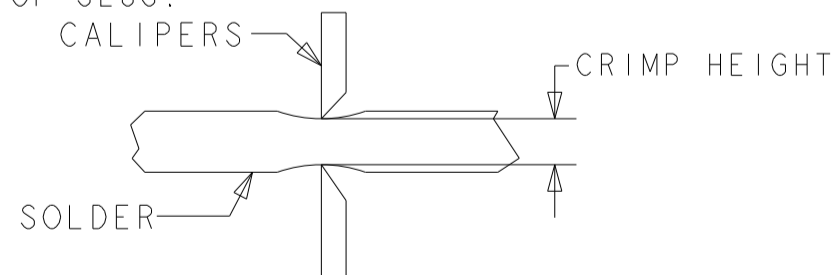

6. UNLESS SPECIFIED OTHERWISE TORQUE VALUES SHALL BE USED PER DOCUMENT, 101-35000.

**\*WARNING**  
ON INSTALLATION, SET WIRE DISC TO CRIMP HEIGHT REFERENCE SETTING FOR LARGEST WIRE SIZE. CRIMP HEIGHT REFERENCE SETTINGS GREATER THAN THE VALUE SHOWN MAY CAUSE DAMAGE TO THE CRIMP TOOLING, REFER TO THE INSTRUCTION SHEET FOR PROPER SETUP AND ADJUSTMENTS.

| LOC | DIST | REVISIONS |     |               |           |     |      |
|-----|------|-----------|-----|---------------|-----------|-----|------|
| A   | 66   | P         | LTN | DESCRIPTION   | DATE      | DWN | APVD |
|     |      | A         |     | ORIGINAL      | 01OCT2012 | BW  | TE   |
|     |      | B         |     | ECR-18-014670 | 15SEP2018 | JAH | TE   |
|     |      | C         |     | ECR-21-007166 | 05AUG2021 | FJ  | TE   |

|   |       |     |             |                                  |                               |   |
|---|-------|-----|-------------|----------------------------------|-------------------------------|---|
| - | 1     | 1   | 2119641-1   | FEED CAM, AIR FEED               | 248                           |   |
| - | 1     | 1   | 2844940-3   | AIR FEED MODULE                  | 238                           |   |
| - | 1     | 1   | 467281-1    | RETAINER, SHEAR, FLOATING        | 207                           |   |
| - | 1     | 1   | 2161936-1   | HOLDER, SHEAR, FLOATING          | 206                           |   |
| - | 1     | 1   | 467500-1    | SHEAR, FLOATING                  | 205                           |   |
| - | 1     | 1   | 1-18028-0   | WASHER, FLAT, REG M8             | 192                           |   |
| - | REF   | REF | 994970-2    | COUNTER, MAGNETIC                | 164                           |   |
| - | 1     | 1   | 2161937-2   | STABILIZER                       | 154                           |   |
| - | 1     | 1   | 1803607-4   | DOCUMENTATION PACKAGE            | 71                            |   |
| - | 1     | 1   | 3-18032-3   | SCR, SET, FLT PNT, M3 X 20.0     | 70                            |   |
| - | 1     | 1   | 2-18032-2   | SCR, SET, FLT PNT, M3 X 10.0     | 69                            |   |
| - | 1     | 1   | 2119740-1   | TAG, IDENTIFICATION              | 67                            |   |
| - | 2     | 2   | 2168078-1   | SCREW, DRIVE, RH, RoHS, 2 x .188 | 66                            |   |
| - | 3     | 3   | 2168400-4   | SHCS, LOW HEAD, RoHS, M4 X 8     | 60                            |   |
| - | -     | -   | 5-18022-5   | SCR, HEX HD CAP, M4 X 6.0        | 59                            |   |
| - | 4     | 4   | 2168400-1   | SHCS, LOW HEAD, RoHS, M4 X 12    | 57                            |   |
| - | 2     | 2   | 2168083-2   | SCR, SKT HD CAP, RoHS, M4 X 8.0  | 56                            |   |
| - | 2     | 2   | 5018030-1   | NUT, HEX, REG, RoHS, M3          | 54                            |   |
| - | 2     | 2   | 986965-8    | NUT, LOCK, HEX, TORQUE (M4)      | 53                            |   |
| - | 1     | 1   | 2352966-1   | FEED FINGER                      | 51                            |   |
| - | 1     | 1   | 18023-9     | SCR, SKT HD CAP M4 X 6.0         | 49                            |   |
| - | 1     | 1   | 1-2119655-5 | APPLICATOR BASIC ASSEMBLY, EF    | 46                            |   |
| - | 1     | 1   | 1803517-1   | RAM ASSEMBLY, EF ATLANTIC        | 44                            |   |
| - | 1     | 1   | 1803602-1   | SCR, BHSC, RoHS (M8 X 25)        | 41                            |   |
| - | 2     | 2   | 5-22278-1   | SPRING, COMPRESSION              | 36                            |   |
| - | 8     | 8   | 1-18028-2   | WASHER, FLAT, REG M4             | 33                            |   |
| - | 2     | 2   | 2079383-4   | SCR, BHSC, RoHS (M4 X 8)         | 31                            |   |
| - | 2     | 2   | 2168083-2   | SCR, SKT HD CAP, RoHS, M4 X 8.0  | 29                            |   |
| - | 1     | 1   | 690455-3    | STRIPPER, FRONT CASTING          | 27                            |   |
| - | 2     | 2   | 1-2168083-6 | SCR, SKT HD CAP, RoHS, M4 X 35   | 25                            |   |
| - | 1     | 1   | 2161941-2   | PLATE, GUIDE, STRIP              | 24                            |   |
| - | 2     | 2   | 22281-9     | SPRING, COMPRESSION              | 22                            |   |
| - | 1     | 1   | 2161948-1   | DRAG                             | 20                            |   |
| - | 1     | 1   | 683736-1    | GUIDE, STRIP, REAR               | 19                            |   |
| - | 1     | 1   | 683737-1    | FRONT STRIP GUIDE                | 18                            |   |
| - | 4     | 4   | 1-2079383-1 | SCR, BHSC, RoHS (M6 X 12)        | 17                            |   |
| - | 1     | 1   | 4-22280-7   | SPRING, COMPRESSION              | 13                            |   |
| - | 1     | 2   | 1           | 2161935-3                        | ANVIL, RIGHT HAND             | 8 |
| - | 1     | 1   | 1           | 2161957-1                        | DEPRESSOR, SHEAR              | 5 |
| - | 1     | 1   | 1           | 238011-2                         | BLOCK, CRIMPER SPACER         | 4 |
| - | 1     | 1   | 1           | 2161331-1                        | SPACER, WIRE FUNNEL DEPRESSOR | 2 |
| - | 1     | 2   | 1           | 467342-4                         | CRIMPER, RIGHT HAND           | 1 |
| - | 77-72 | -2  |             | PART NO                          |                               |   |
| - |       |     |             | DESCRIPTION                      | ITEM NO                       |   |

ATLANTIC VERSION  
Shown on sheets 1 of 4 & 2 of 4  
(Pacific version shown on sheets 3 of 4 & 4 of 4)

| DIMENSIONS: |         | TOLERANCES UNLESS OTHERWISE SPECIFIED: |         | APVD    |         | NAME   |        |
|-------------|---------|--|---------|---------|---------|--------|--------|
| mm          | 0 PLC ± | 1 PLC ±                                | 2 PLC ± | 3 PLC ± | 4 PLC ± | ANGLES | FINISH |
| MATERIAL    |         | FINISH                                 |         | WEIGHT  |         | SCALE  |        |
| -           |         | -                                      |         | -       |         | 1:1    |        |



Ocean End Feed Applicator

|  |           |              |       |
|--|-----------|--------------|-------|
| Customer Accessible Production Drawing | SCALE 1:1 | SHEET 1 OF 4 | REV C |
|--|-----------|--------------|-------|

| LOC | DIST | REVISIONS   |      |     |      |
|-----|------|-------------|------|-----|------|
| P   | LTN  | DESCRIPTION | DATE | OWN | APVD |
| A   | 66   | SEE SHEET 1 | -    | -   | -    |
|     |      |             |      |     |      |
|     |      |             |      |     |      |

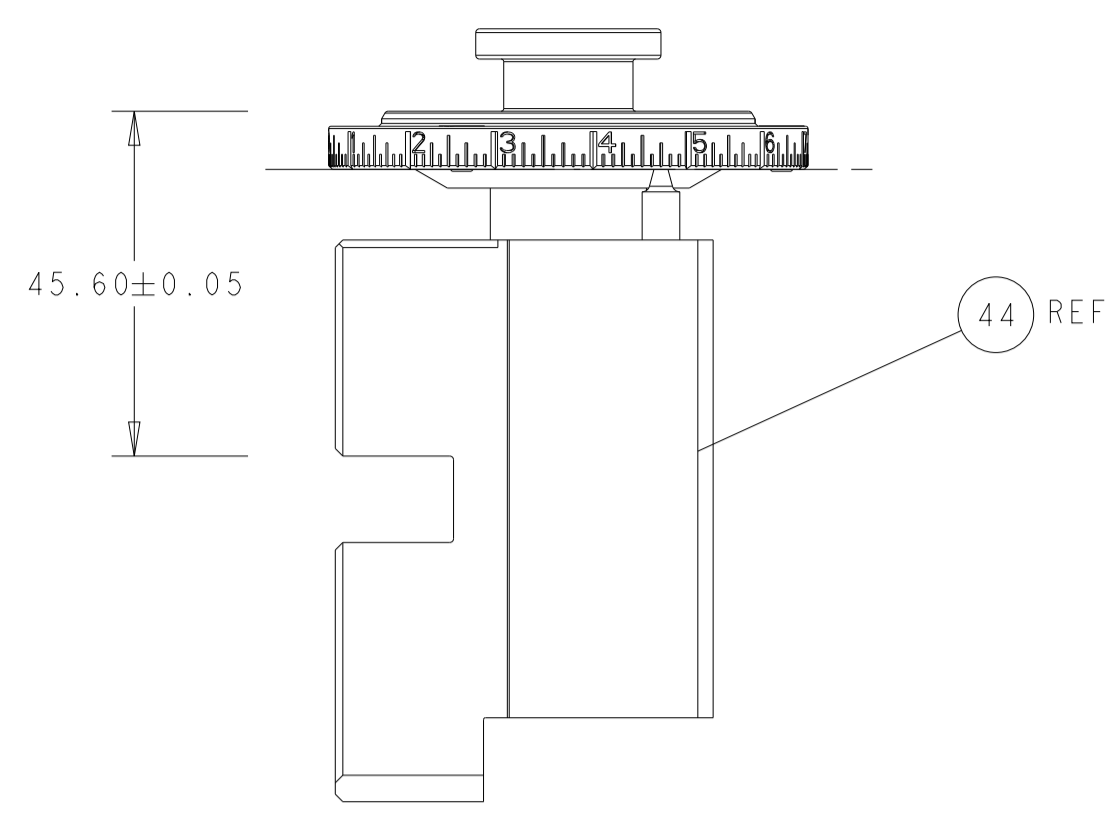

RAM SET-UP

FEED TYPE

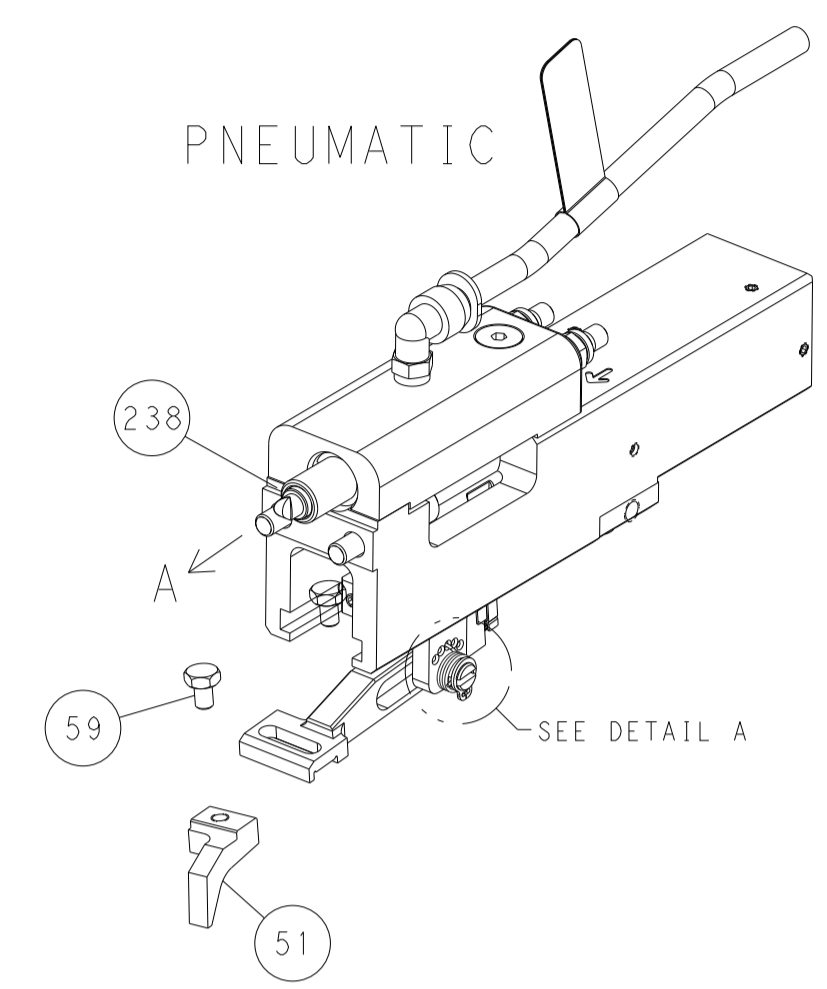

FEED SPRING SETTING POSITION

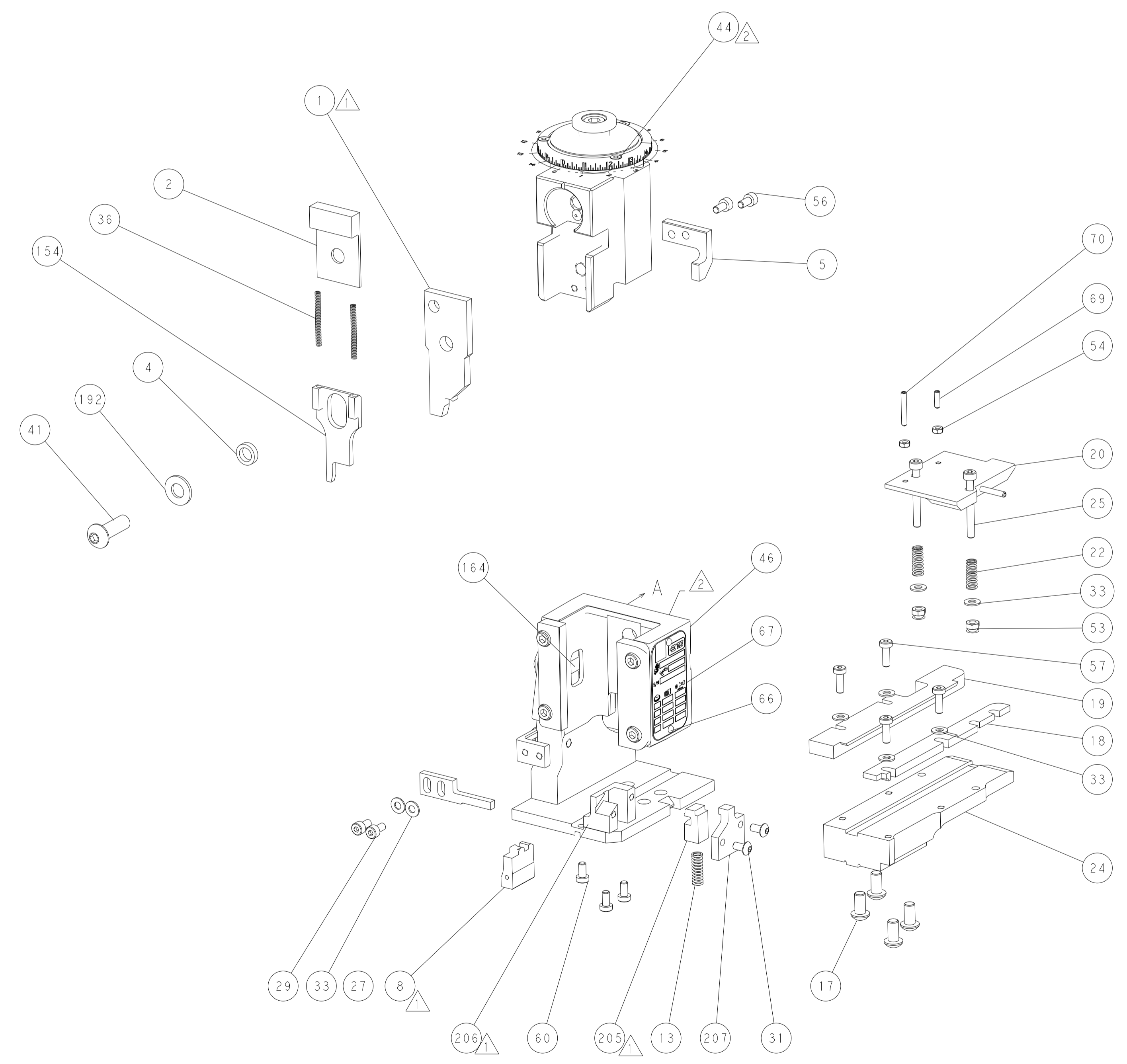
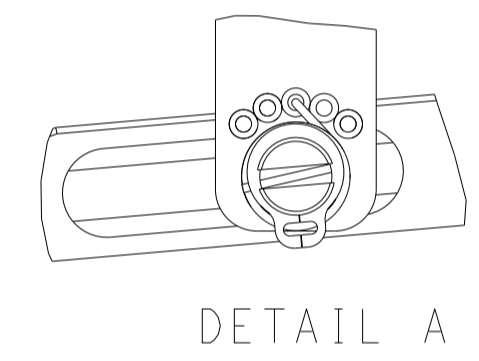

CAM POSITION

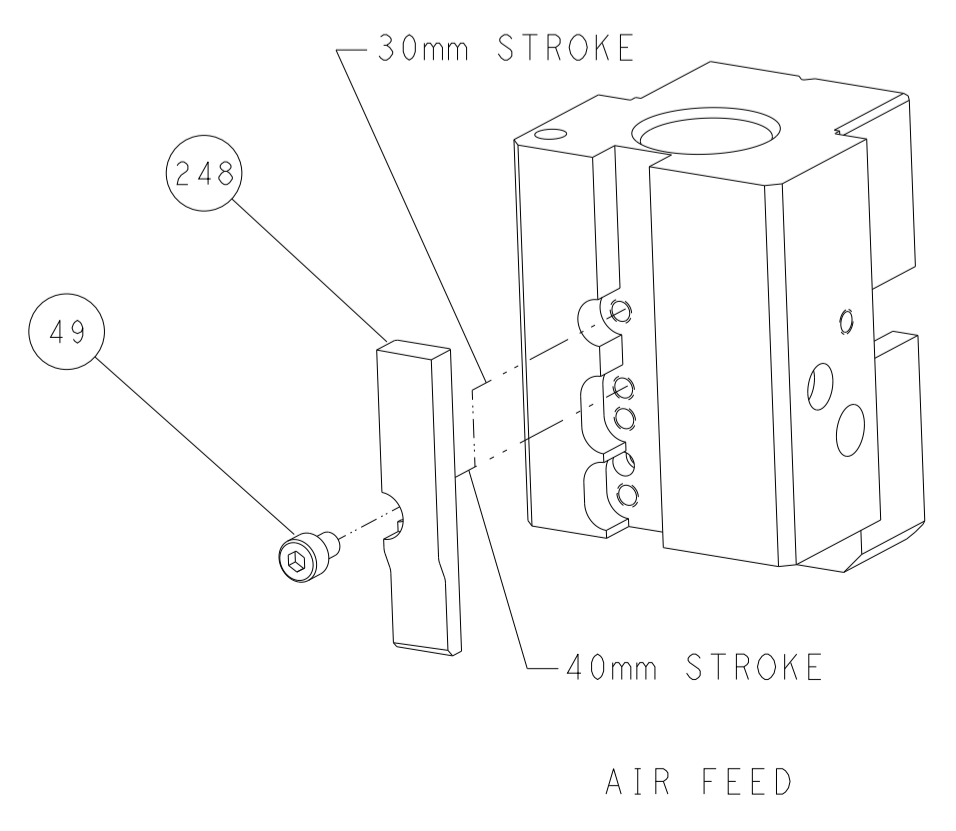

ATLANTIC VERSION  
 Shown on sheets 1 of 4 & 2 of 4  
 (Pacific version shown on sheets 3 of 4 & 4 of 4)

|   |  |   |   |
|---|--|---|---|
| <small>THIS DRAWING IS UNPUBLISHED. RELEASED FOR PUBLICATION 2012. COPYRIGHT 2012 BY TYCO ELECTRONICS CORPORATION. ALL RIGHTS RESERVED.</small> |  | DWN: B. WEAVER 19JUN2012<br>CHK: T. ELBIN 19JUN2012<br>APVD: T. ELBIN 19JUN2012                                       | TE Connectivity<br>Harrisburg, PA 17105-3608  |
| DIMENSIONS: mm<br>  |  | TOLERANCES UNLESS OTHERWISE SPECIFIED:<br>0 PLC ±<br>1 PLC ±<br>2 PLC ±<br>3 PLC ±<br>4 PLC ±<br>ANGLES ±<br>FINISH ± | NAME: Ocean End Feed Applicator<br>SIZE: A1<br>CAGE CODE: 00779<br>DRAWING NO: C-2150268<br>SCALE: 1:1<br>SHEET: 2 of 4<br>REV: C |
| MATERIAL:   |  | WEIGHT:   | RESTRICTED TO:  |

| PART NUMBER | REVISION | DESCRIPTION              | FEED TYPE |
|-------------|----------|--------------------------|-----------|
| 2-2150268-2 | C        | FINE CRIMP HEIGHT ADJUST | PNEUMATIC |
| 7-2150268-7 | A        | CRIMP TOOLING KIT        | -         |

PACIFIC VERSION TERMINATOR INTERFACE ADAPTER

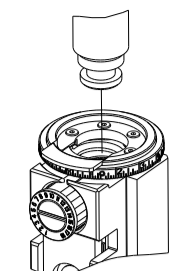

| APPLICATOR DATA                |                |      |
|--------------------------------|----------------|------|
| CRIMP                          | SIZE           | TYPE |
| WIRE                           | 6.02 mm [.237] | D    |
| INSUL                          | -              | -    |
| APPL INSTRUCTIONS<br>408-35043 |                |      |

| TERMINAL DATA: TE TERMINAL                         |   | TE CRIMP SPEC |
|--|---|---------------|
| TERMINAL NAME: RECPT, ULTRA-FAST FLAG, .187 SERIES |   |               |
| WIRE STRIP LENGTH<br>7.51-8.33 mm [.296-.328 IN]   | INSULATION DIAMETER RANGE<br>Ø .185 MAX |               |
| TERMINAL APPLICATION SPECIFICATION<br>114-2123     |   |               |
| TERMINALS APPLIED 4                                |   |               |
| TE TERMINAL  | TE TERMINAL                             | TE TERMINAL   |
| 3-520338-2   | 6-520338-2                              | 9-520340-2    |
| 5-520338-2   | 3-520340-2                              |               |

| WIRE SIZE | CRIMP HEIGHT mm [INCH]      | CRIMP HEIGHT REFERENCE SETTING | Ø SOLDER        |
|-----------|-----------------------------|--------------------------------|-----------------|
| 14        | 1.905+/-0.05 [.075+/- .002] | 4.8                            | .19 in [4.83mm] |
| 16        | 1.778+/-0.05 [.070+/- .002] | 6.0                            | .19 in [4.83mm] |

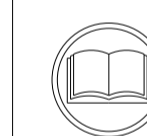

- 1 RECOMMENDED SPARE PARTS
- 2 REFER TO SUPPLIED INSTRUCTION SHEET FOR CLEANING, LUBRICATION AND STORAGE OF APPLICATOR.
- 3 CRIMP HEIGHT REFERENCE SETTING WAS THE SETTING USED WHEN THE APPLICATOR WAS QUALIFIED AT THE FACTORY. ADJUSTMENT MAY BE NECESSARY WHEN RUNNING APPLICATOR IN THE FIELD.
- 4 TERMINAL PITCH NOT COMPATIBLE WITH MECHANICAL FEED.
- 5 TO CHECK CRIMP HEIGHT, CRIMP SOLDER (Ø.19 IN [4.83mm] 60/40 SOLID CORE) AND MEASURE AT CENTER OF SLUG.

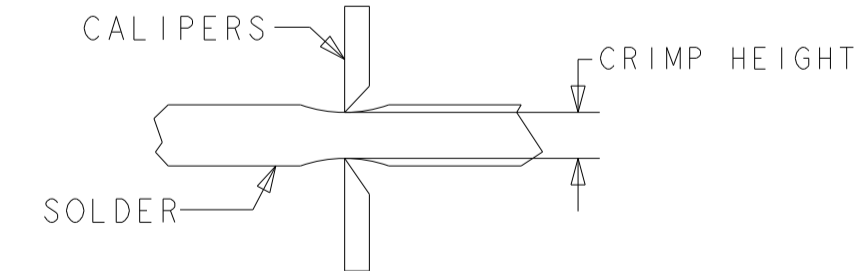

6. UNLESS SPECIFIED OTHERWISE TORQUE VALUES SHALL BE USED PER DOCUMENT, 101-35000.

**\*WARNING**  
ON INSTALLATION, SET WIRE DISC TO CRIMP HEIGHT REFERENCE SETTING FOR LARGEST WIRE SIZE. CRIMP HEIGHT REFERENCE SETTINGS GREATER THAN THE VALUE SHOWN MAY CAUSE DAMAGE TO THE CRIMP TOOLING, REFER TO THE INSTRUCTION SHEET FOR PROPER SETUP AND ADJUSTMENTS.

| LOC | DIST | REVISIONS |     |             |      |     |      |
|-----|------|-----------|-----|-------------|------|-----|------|
|     |      | P         | LTN | DESCRIPTION | DATE | OWN | APVD |
| A   | 66   | -         | -   | SEE SHEET 1 | -    | -   | -    |

|   |     |             |                                  |     |
|---|-----|-------------|----------------------------------|-----|
| - | 1   | 2844940-3   | AIR FEED MODULE                  | 238 |
| - | 1   | 467281-1    | RETAINER, SHEAR, FLOATING        | 207 |
| - | 1   | 2161936-1   | HOLDER, SHEAR, FLOATING          | 206 |
| - | 1   | 467500-1    | SHEAR, FLOATING                  | 205 |
| - | 1   | 1-18028-0   | WASHER, FLAT, REG M8             | 192 |
| - | 4   | 2079383-9   | SCR, BHSC, RoHS (M6 X 20)        | 186 |
| - | REF | 994970-2    | COUNTER, MAGNETIC                | 164 |
| - | 1   | 2161937-2   | STABILIZER                       | 154 |
| - | 1   | 2119641-2   | FEED CAM, AIR FEED               | 152 |
| - | 3   | 2168400-5   | SHCS, LOW HEAD, RoHS, M4 X 20    | 144 |
| - | 1   | 1-2119655-6 | APPLICATOR BASIC ASSEMBLY, EF    | 141 |
| - | 1   | 1803518-1   | RAM ASSEMBLY, EF PACIFIC         | 140 |
| - | 1   | 1803607-4   | DOCUMENTATION PACKAGE            | 71  |
| - | 1   | 3-18032-3   | SCR, SET, FLT PNT, M3 X 20.0     | 70  |
| - | 1   | 2-18032-2   | SCR, SET, FLT PNT, M3 X 10.0     | 69  |
| - | 1   | 2119740-1   | TAG, IDENTIFICATION              | 67  |
| - | 2   | 2168078-1   | SCREW, DRIVE, RH, RoHS, 2 x .188 | 66  |
| - | 1   | 5-18022-5   | SCR, HEX HD CAP, M4 X 6.0        | 59  |
| - | 4   | 2168400-1   | SHCS, LOW HEAD, RoHS, M4 X 12    | 57  |
| - | 2   | 2168083-2   | SCR, SKT HD CAP, RoHS, M4 X 8.0  | 56  |
| - | 2   | 5018030-1   | NUT, HEX, REG, RoHS, M3          | 54  |
| - | 2   | 986965-8    | NUT, LOCK, HEX, TORQUE (M4)      | 53  |
| - | 1   | 2352966-1   | FEED FINGER                      | 51  |
| - | 1   | 18023-9     | SCR, SKT HD CAP M4 X 6.0         | 49  |
| - | 1   | 1803602-1   | SCR, BHSC, RoHS (M8 X 25)        | 41  |
| - | 2   | 5-22278-1   | SPRING, COMPRESSION              | 36  |
| - | 8   | 1-18028-2   | WASHER, FLAT, REG M4             | 33  |
| - | 2   | 2079383-4   | SCR, BHSC, RoHS (M4 X 8)         | 31  |
| - | 2   | 2168083-2   | SCR, SKT HD CAP, RoHS, M4 X 8.0  | 29  |
| - | 1   | 690455-3    | STRIPPER, FRONT CASTING          | 27  |
| - | 2   | 1-2168083-6 | SCR, SKT HD CAP, RoHS, M4 X 35   | 25  |
| - | 1   | 2161941-2   | PLATE, GUIDE, STRIP              | 24  |
| - | 2   | 22281-9     | SPRING, COMPRESSION              | 22  |
| - | 1   | 2161948-1   | DRAG                             | 20  |
| - | 1   | 683736-1    | GUIDE, STRIP, REAR               | 19  |
| - | 1   | 683737-1    | FRONT STRIP GUIDE                | 18  |
| - | 1   | 4-22280-7   | SPRING, COMPRESSION              | 13  |
| 1 | 1   | 2161935-3   | ANVIL, RIGHT HAND                | 8   |
| - | 1   | 2161957-1   | DEPRESSOR, SHEAR                 | 5   |
| - | 1   | 238011-2    | BLOCK, CRIMPER SPACER            | 4   |
| - | 1   | 2161331-1   | SPACER, WIRE FUNNEL DEPRESSOR    | 2   |
| 1 | 1   | 467342-4    | CRIMPER, RIGHT HAND              | 1   |

PACIFIC VERSION  
Shown on sheets 3 of 4 & 4 of 4  
(Atlantic version shown on sheets 1 of 4 & 2 of 4)

| DIMENSIONS: |         | TOLERANCES UNLESS OTHERWISE SPECIFIED: |         | MATERIAL: |         | FINISH: |        | WEIGHT: |  | SCALE: |  |
|-------------|---------|--|---------|-----------|---------|---------|--------|---------|--|--------|--|
| mm          | 0 PLC ± | 1 PLC ±                                | 2 PLC ± | 3 PLC ±   | 4 PLC ± | ANGLES  | FINISH |         |  |        |  |
|             |         |  |         |           |         |         |        |         |  |        |  |

| LOC | DIST | REVISIONS   |      |     |      |
|-----|------|-------------|------|-----|------|
| P   | LTN  | DESCRIPTION | DATE | OWN | APVD |
| A   | 66   | SEE SHEET 1 | -    | -   | -    |
|     |      |             |      |     |      |
|     |      |             |      |     |      |

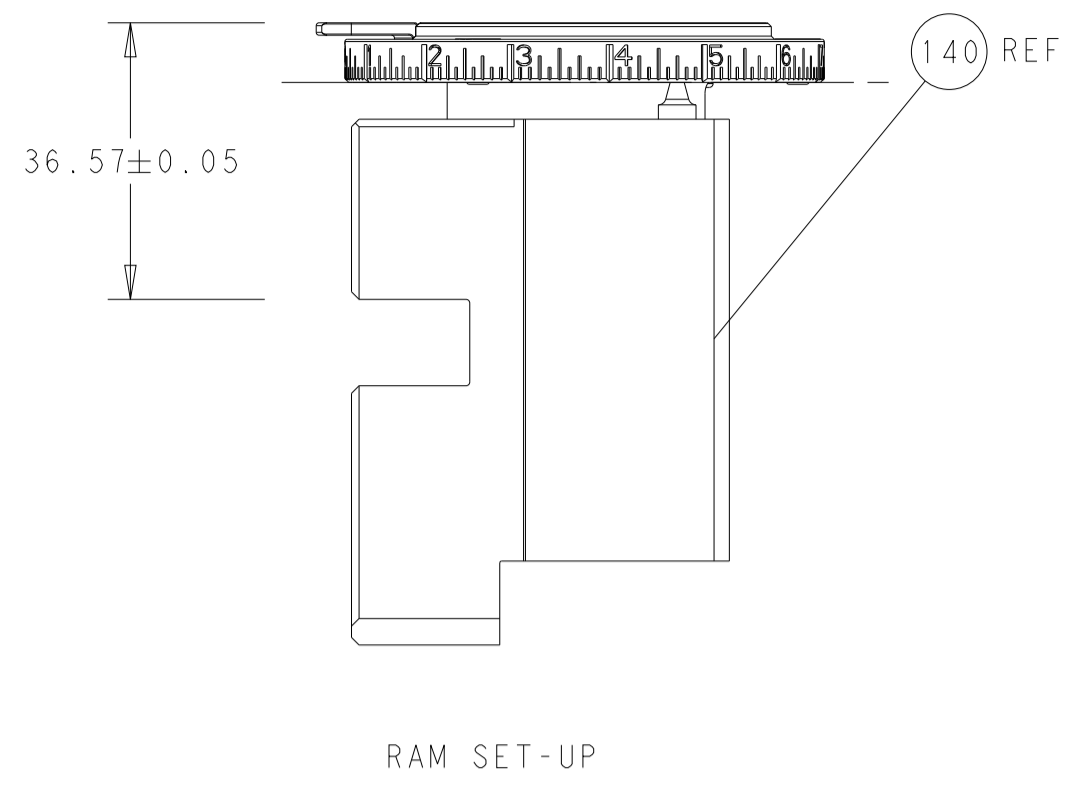

FEED TYPE

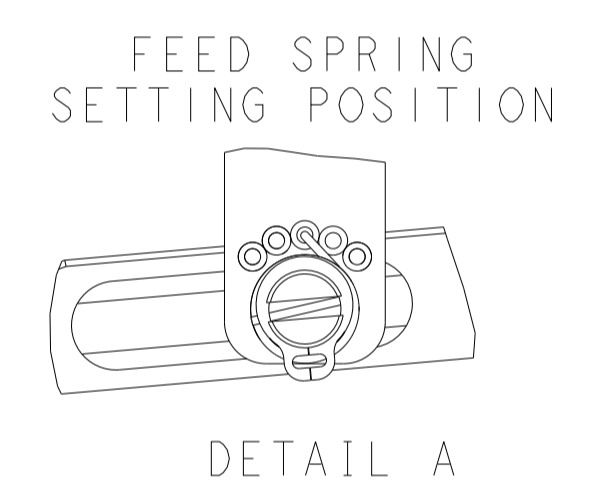
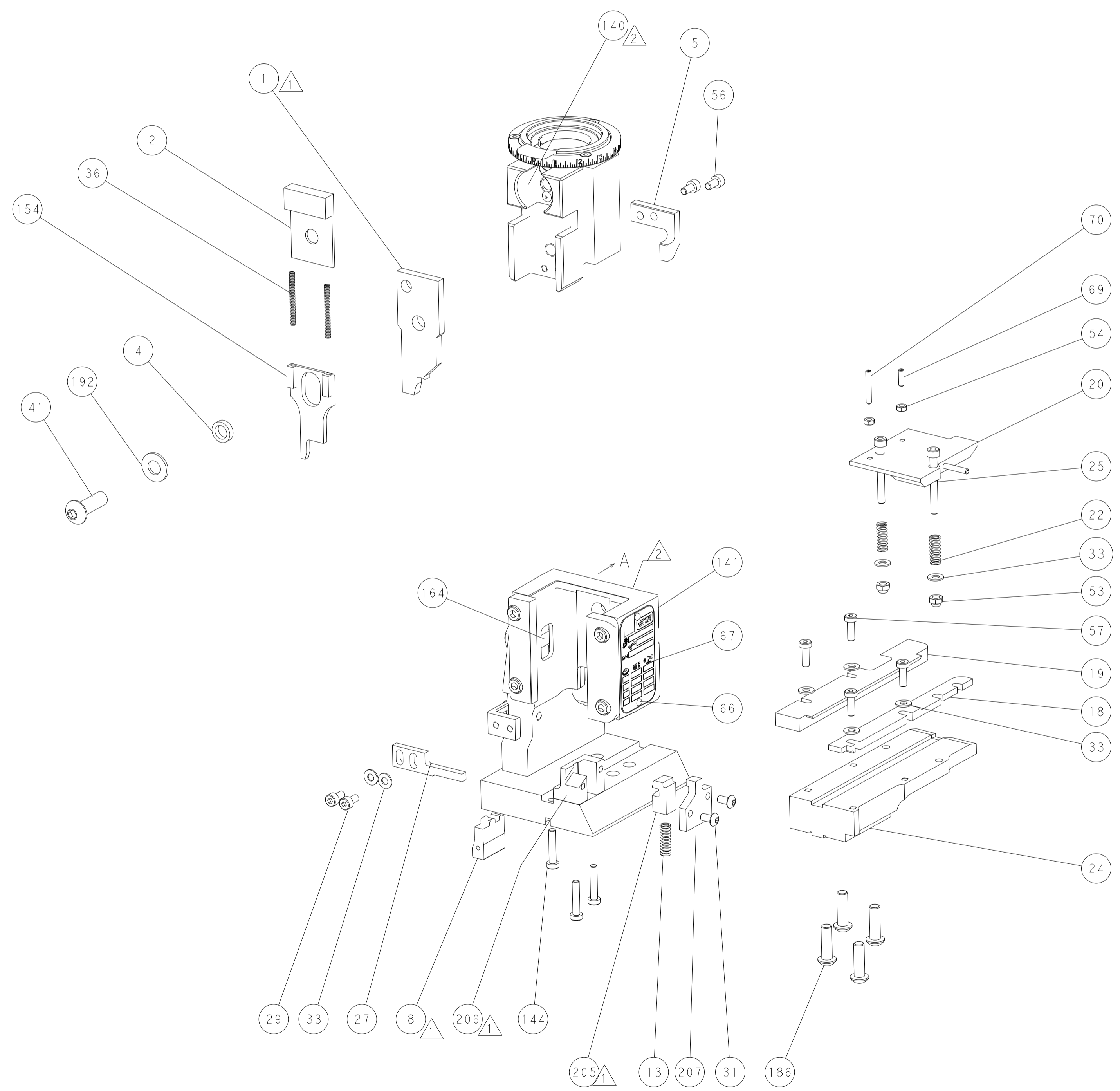
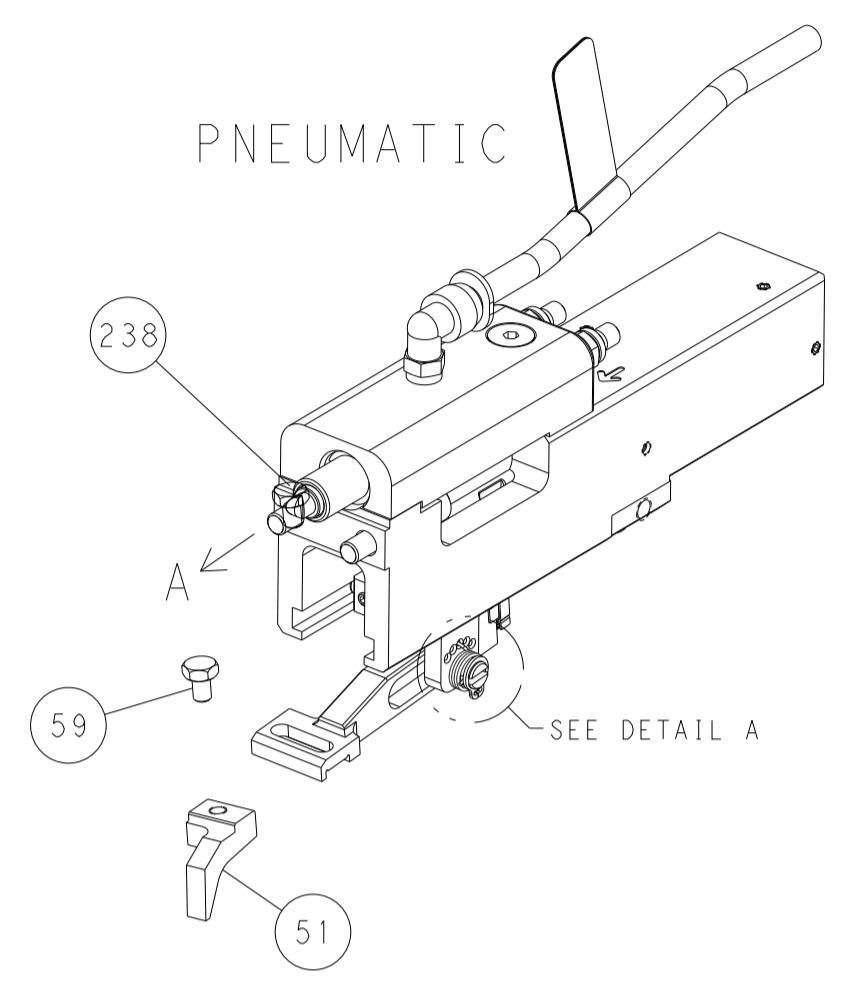

CAM POSITION

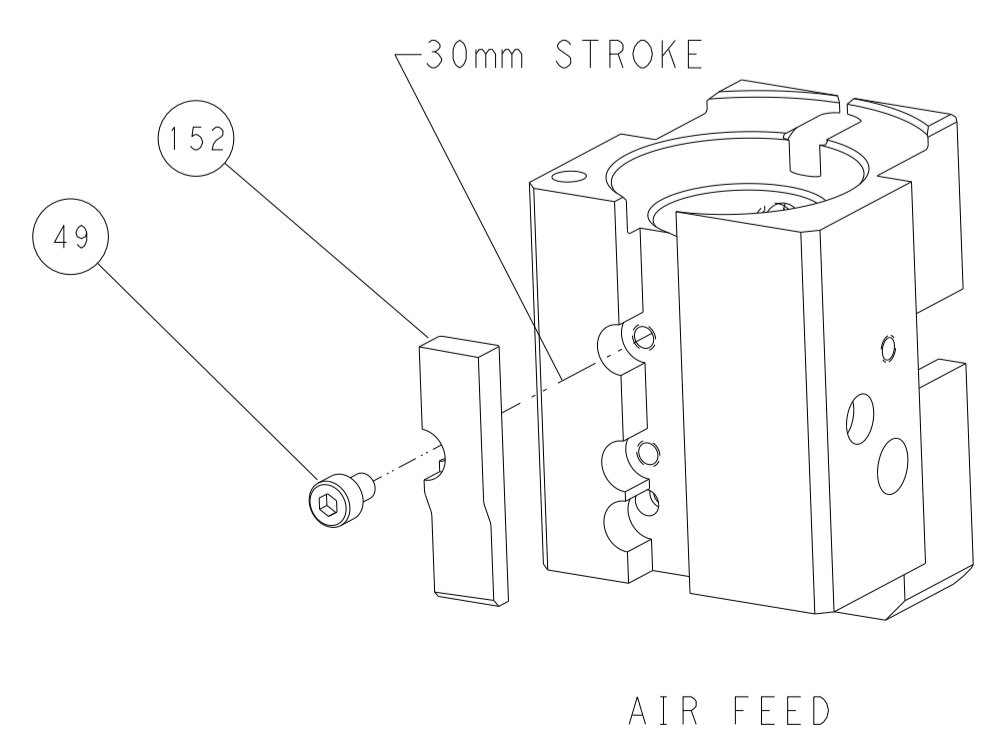

PACIFIC VERSION  
 Shown on sheets 3 of 4 & 4 of 4  
 (Atlantic version shown on sheets 1 of 4 & 2 of 4)

|   |  |  |  |
|---|--|--|--|
| <small>THIS DRAWING IS UNPUBLISHED. RELEASED FOR PUBLICATION 2012 BY TYCO ELECTRONICS CORPORATION. ALL RIGHTS RESERVED.</small>         |  | DWN: B. WEAVER 19JUN2012<br>CHK: T. ELBIN 19JUN2012<br>APVD: T. ELBIN 19JUN2012  | TE Connectivity<br>Harrisburg, PA 17105-3608 |
| DIMENSIONS: mm<br>TOLERANCES UNLESS OTHERWISE SPECIFIED:<br>0 PLC ±<br>1 PLC ±<br>2 PLC ±<br>3 PLC ±<br>4 PLC ±<br>ANGLES ±<br>FINISH ± |  | NAME: Ocean End Feed Applicator<br>PRODUCT SPEC:<br>APPLICATION SPEC:<br>WEIGHT: A1 00779<br>SCALE: 1:1<br>SHEET: 4 of 4<br>REV: C | RESTRICTED TO:                               |
| MATERIAL:   |  | Customer Accessible Production Drawing   |  |