

PART NUMBER	REVISION	DESCRIPTION	FEED TYPE
2150397-1	C	FINE CRIMP HEIGHT ADJUST	MECHANICAL
2150397-2	C	FINE CRIMP HEIGHT ADJUST	PNEUMATIC
7-2150397-1	C	MECHANICAL AND CRIMP TOOLING KIT	MECHANICAL
7-2150397-2	C	PNEUMATIC AND CRIMP TOOLING KIT	PNEUMATIC
7-2150397-7	A	CRIMP TOOLING KIT	-

ATLANTIC VERSION TERMINATOR INTERFACE ADAPTER

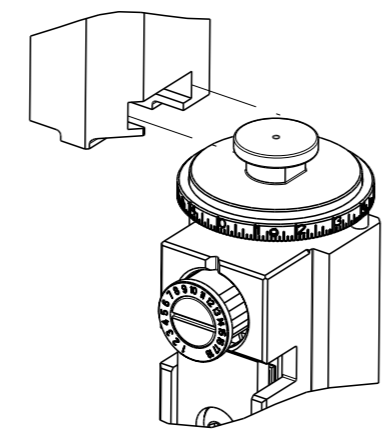

APPLICATOR DATA		
CRIMP	SIZE	TYPE
WIRE	1.78 mm [.070]	F
INSUL	3.56 mm [.140]	O

APPLICATOR INSTRUCTIONS
408-35043

TERMINAL DATA: TE TERMINAL		TE CRIMP SPECIFICATION	
TERMINAL NAME: RECEPTACLE, FASTON FLAG .187 SERIES			
WIRE STRIP LENGTH 4.39-5.16 mm [.173-.203 IN]		INSULATION DIAMETER RANGE Ø1.52-2.79 mm [.060-.110 IN]	
TERMINAL APPLICATION SPECIFICATION 114-2079			
TERMINALS APPLIED			
TE TERMINAL 1742086-1	TE TERMINAL 1742086-2	TE TERMINAL 1742087-1	TE TERMINAL 1742087-2

WIRE SIZE	CRIMP HEIGHT mm [INCH]	CRIMP HEIGHT REFERENCE SETTING
18 AWG	1.27 +/- 0.05 [0.050 +/- .002]	4.7
20 AWG	1.14 +/- 0.05 [0.045 +/- .002]	6.2
22 AWG	1.06 +/- 0.05 [0.042 +/- .002]	7.1

- 1 RECOMMENDED SPARE PARTS
- 2 REFER TO SUPPLIED INSTRUCTION SHEET FOR CLEANING, LUBRICATION AND STORAGE OF APPLICATOR.
- 3 APPLY PART NUMBER 2-23419-6 LOCTITE TO THREADS OF ITEM 242.
- 4 CRIMP HEIGHT REFERENCE SETTING WAS THE SETTING USED WHEN THE APPLICATOR WAS QUALIFIED AT THE FACTORY. ADJUSTMENT MAY BE NECESSARY WHEN RUNNING APPLICATOR IN THE FIELD.
- 5 TERMINAL LUBRICANT IS RECOMMENDED.
- 6 UNLESS SPECIFIED OTHERWISE TORQUE VALUES SHALL BE USED PER DOCUMENT, 101-35000.

***WARNING**
ON INSTALLATION, SET WIRE DISC TO CRIMP HEIGHT REFERENCE SETTING FOR LARGEST WIRE SIZE. CRIMP HEIGHT REFERENCE SETTINGS GREATER THAN THE VALUE SHOWN MAY CAUSE DAMAGE TO THE CRIMP TOOLING. REFER TO THE INSTRUCTION SHEET FOR PROPER SETUP AND ADJUSTMENTS.

ATLANTIC VERSION
Shown on sheets 1 of 4 & 2 of 4
(Pacific version shown on sheets 3 of 4 & 4 of 4)

LOC	DIST	REVISIONS					
		P	LYR	DESCRIPTION	DATE	OWN	APVD
A	66	A1		ECR-15-010666	17JUL2015	KH	UG
		B		ECR-16-005266	11APR2016	RK	GB
		C		ECR-19-010232	30JUN2019	TB	GB
		C1		ECR-20-017908	17DEC2020	JWC	GB

-	1	-	1	-	2119640-1	PUSH ROD, AIR FEED	250	
-	1	-	1	-	1803259-1	BUSHING, FLANGED	249	
-	1	-	1	-	2119641-1	FEED CAM, AIR FEED	248	
-	1	1	1	1	2119082-9	CAM, SNAIL, INSULATION ADJUSTMENT	244	
-	1	1	1	1	2079764-1	WASHER, WAVE SPRING, CREST-TO-CREST	243	
3	-	1	1	1	2119083-1	RETAINER, INSULATION DIAL	242	
-	-	1	-	1	2119580-1	MECHANICAL FEED ASSEMBLY	239	
-	1	-	1	-	2063440-1	AIR FEED MODULE	238	
-	1	1	1	1	1-18028-0	WASHER, FLAT, REG M8	192	
-	2	2	2	2	1-2168083-1	SCR, SKT HD CAP, RoHS, M3 X 6	189	
-	1	1	1	1	1-455888-5	SPACER, CRIMPER	188	
-	2	-	2	-	21045-3	RING, RETAIN, EXTERN, 3/16 CRESCENT	172	
-	REF	REF	REF	REF	994970-2	COUNTER, MAGNETIC	164	
-	1	-	1	-	240638-1	SPRING, FEED FINGER	163	
-	1	-	1	-	3-23627-7	PIN, RETAIN, GRVD, 3/16 X .854	137	
5	-	1	1	1	2119955-2	ASSY, LUBRICATOR, END FEED	84	
-	1	1	1	1	1-455888-5	SPACER, CRIMPER	82	
-	1	1	1	1	1803607-2	DOCUMENTATION PACKAGE	71	
-	2	2	2	2	2-18032-2	SCR, SET, FLT PNT, M3 X 10.0	70	
-	1	1	1	1	2119740-1	TAG, IDENTIFICATION	67	
-	2	2	2	2	2168078-1	SCREW, DRIVE, RH, RoHS, 2 x .188	66	
-	1	1	1	1	2168083-2	SCR, SKT HD CAP, RoHS, M4 X 8.0	60	
-	-	1	-	1	5-18022-5	SCR, HEX HD CAP, M4 X 6.0	59	
-	-	1	-	1	2161924-1	FEED FINGER	58	
-	4	4	4	4	2168400-1	SHCS, LOW HEAD, RoHS, M4 X 12	57	
-	2	2	2	2	5018030-1	NUT, HEX, REG, RoHS, M3	54	
-	2	2	2	2	986965-8	NUT, LOCK, HEX, TORQUE (M4)	53	
-	1	-	1	-	2161920-1	NARROW PAWL, EF, AIR	51	
-	1	2	1	2	18023-9	SCR, SKT HD CAP M4 X 6.0	49	
-	-	1	-	1	2119652-1	FEED CAM, PRE FEED	48	
-	-	1	-	1	2119653-1	FEED CAM, POST FEED	47	
-	1	1	1	1	1-2119655-7	APPLICATOR BASIC ASSEMBLY, EF	46	
-	1	1	1	1	1803517-2	RAM ASSEMBLY, EF ATLANTIC	44	
-	1	1	1	1	1803602-2	SCR, BHSC, RoHS (M8 X 40)	41	
-	8	8	8	8	1-18028-2	WASHER, FLAT, REG M4	33	
-	1	1	1	1	2168083-9	SCR, SKT HD CAP, RoHS, M4 X 20	31	
-	1	1	1	1	1-2168083-2	SCR, SKT HD CAP, RoHS, M4 X 25	30	
-	2	2	2	2	2168083-2	SCR, SKT HD CAP, RoHS, M4 X 8.0	29	
-	1	1	1	1	469633-1	BLOCK, SUPPORT	28	
-	1	1	1	1	468281-8	STRIPPER	27	
-	2	2	2	2	1-2168083-6	SCR, SKT HD CAP, RoHS, M4 X 35	25	
-	1	1	1	1	2161922-4	PLATE, STRIP GUIDE	24	
-	2	2	2	2	1-18028-2	WASHER, FLAT, REG M4	23	
-	2	2	2	2	22281-6	SPRING, COMPRESSION	22	
-	1	1	1	1	1633168-2	ARM, STOCK DRAG	21	
-	1	1	1	1	464452-4	DRAG, STOCK	20	
-	1	1	1	1	5-1901696-7	STRIP GUIDE, REAR	19	
-	1	1	1	1	3-1901695-1	STRIP GUIDE, FRONT	18	
-	4	4	4	4	1-2079383-1	SCR, BHSC, RoHS (M6 X 12)	17	
1	-	1	1	1	455961-5	PLATE, FRONT SHEAR	11	
1	-	2	2	2	1-240645-9	SPACER, SHEAR PLATE	10	
1	-	1	1	1	461160-3	PLATE, REAR SHEAR	9	
1	1	2	2	1	1	4-1803000-0	ANVIL, COMBINATION, END FEED	8
1	-	1	1	1	2161927-1	BLADE, SLUG	7	
-	-	-	-	-	-	-	6	
-	-	-	-	-	-	-	5	
-	1	1	1	1	238011-4	BLOCK, CRIMPER SPACER	4	
1	1	2	2	1	1	1803018-8	CRIMPER, INSULATION O	3
-	1	1	1	1	1-455888-7	SPACER, CRIMPER	2	
1	1	2	2	1	1	1803006-6	CRIMPER, WIRE	1

DIMENSIONS:		TOLERANCES UNLESS OTHERWISE SPECIFIED:		OWN: BOB HIGMAN 09DEC2013		TE Connectivity	
mm		0 PLC ±		CHK: T. ELBIN 09DEC2013		Harrisburg, PA 17105-3608	
1 PLC ±		1 PLC ±		APVD: M. CLIFFORD 09DEC2013		NAME: Ocean End Feed	
2 PLC ±		3 PLC ±		PRODUCT SPEC		Applicator	
3 PLC ±		4 PLC ±		APPLICATION SPEC		-	
4 PLC ±		FINISH		SIZE: A1		CAGE CODE: 00779	
MATERIAL:		FINISH:		DRAWING NO: 2150397		RESTRICTED TO:	
-		-		WEIGHT:		SCALE: 1:1	
-		-		Customer Accessible Production Drawing		SHEET 1 OF 4	

LOC	DIST	REV	DESCRIPTION	DATE	OWN	APVD
A	66		SEE SHEET 1			

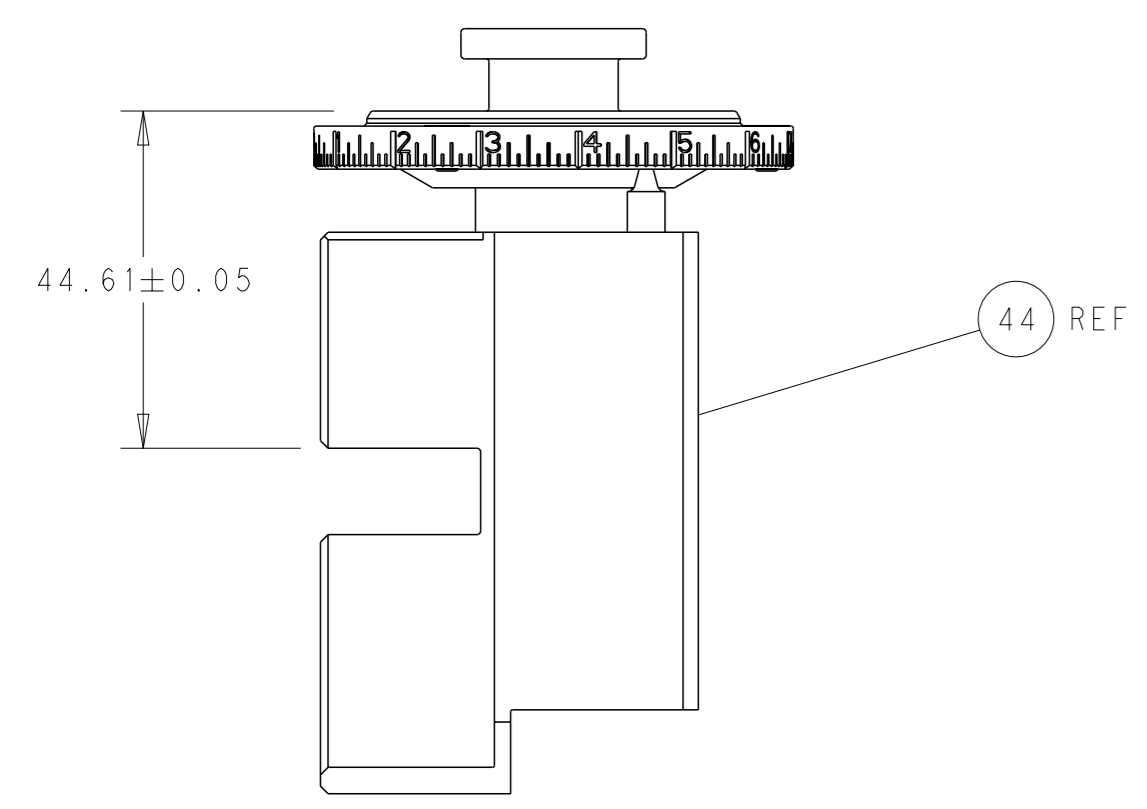

RAM SET-UP

FEED TYPE
MECHANICAL

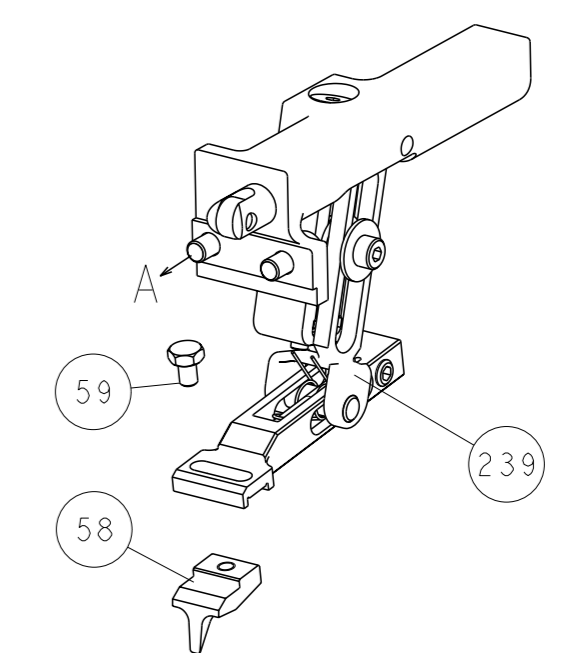

PNEUMATIC

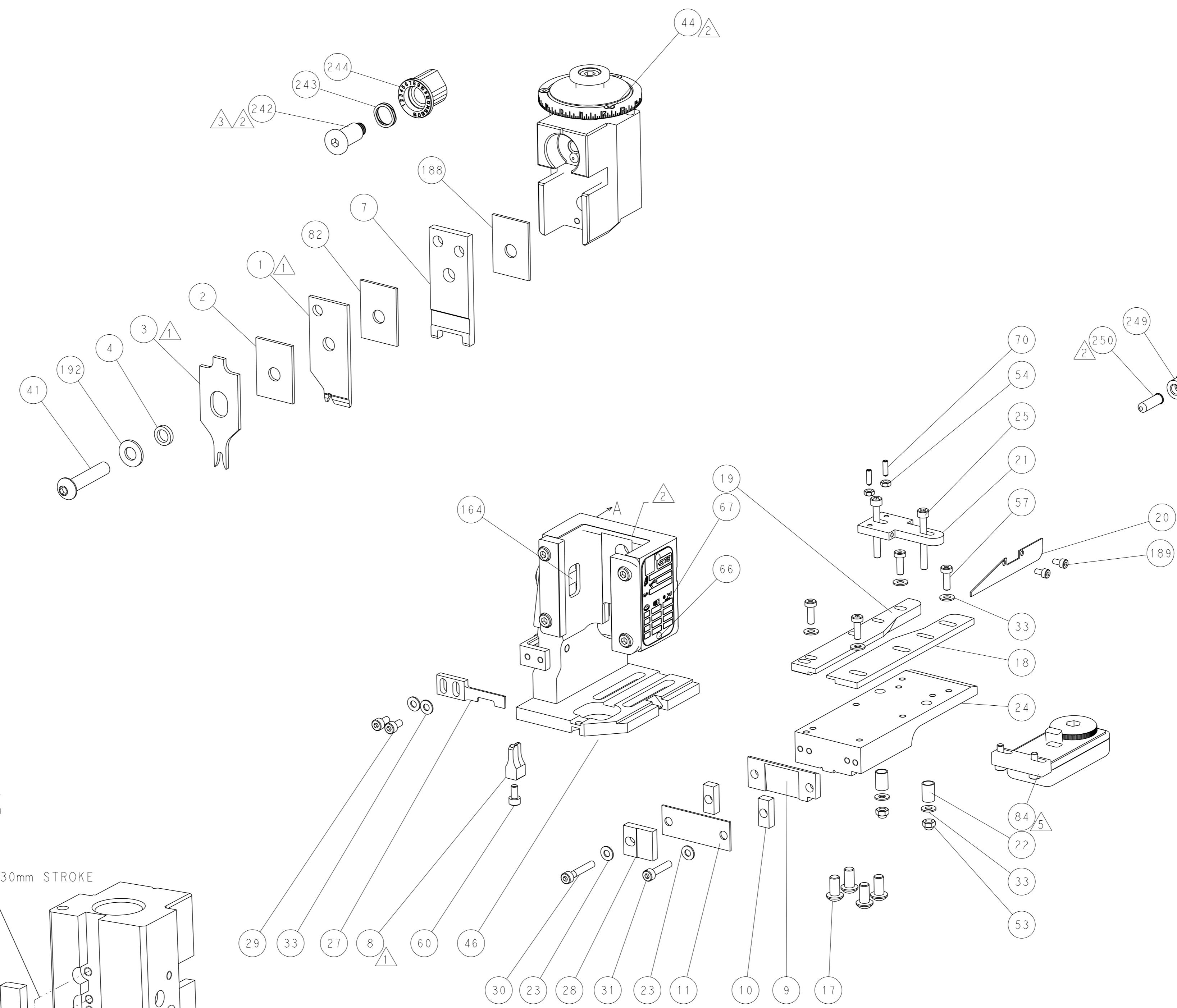
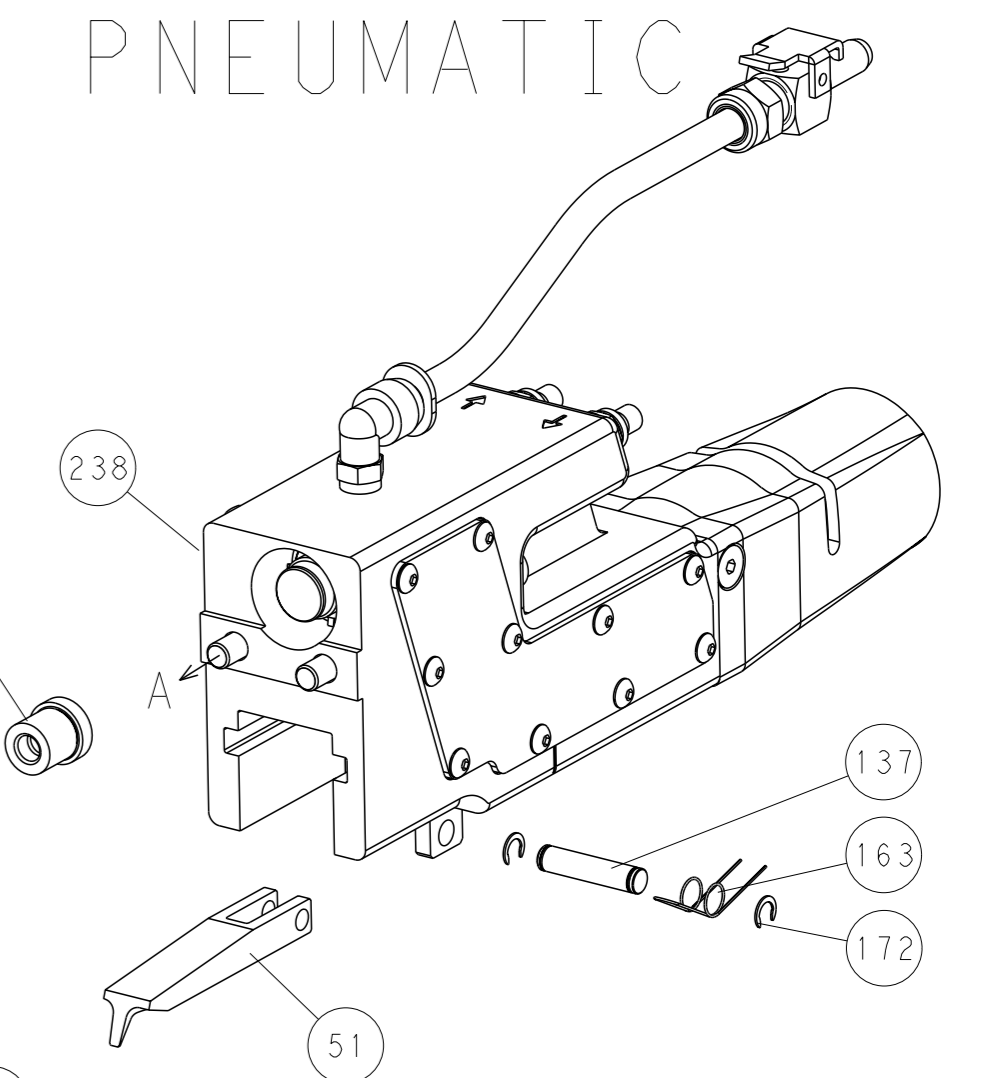

CAM POSITIONS

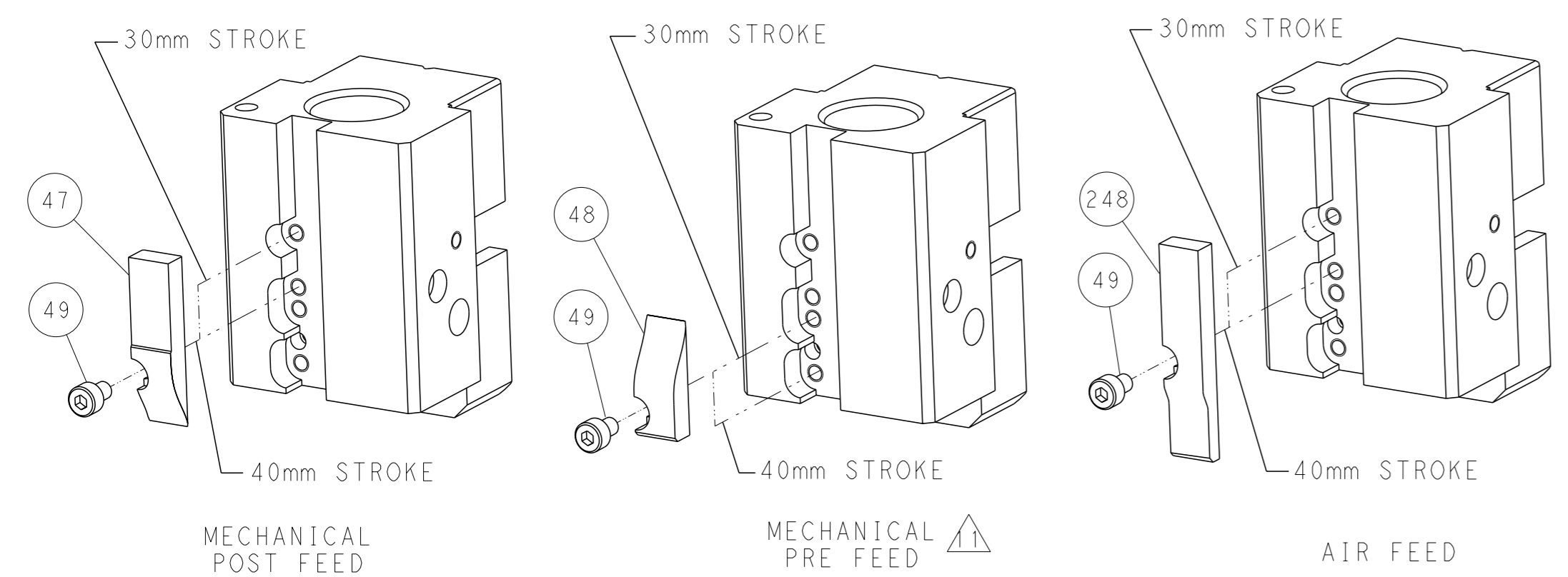

ATLANTIC VERSION
 Shown on sheets 1 of 4 & 2 of 4
 (Pacific version shown on sheets 3 of 4 & 4 of 4)

DIMENSIONS: mm		TOLERANCES UNLESS OTHERWISE SPECIFIED: 0 PLC ± 1 PLC ± 2 PLC ± 3 PLC ± 4 PLC ± ANGLES FINISH ±		OWN BOB HIGMAN 09DEC2013 CHK T. ELBIN 09DEC2013 APVD M. CLIFFORD 09DEC2013 PRODUCT SPEC APPLICATION SPEC WEIGHT Customer Accessible Production Drawing		NAME Ocean End Feed Applicator SIZE CAGE CODE DRAWING NO. A1 00779 ©=2150397 SCALE 1:1 SHEET 2 of 4 REV C1		RESTRICTED TO	
SHEETS 3 & 4 ARE NOT REQUIRED FOR ATLANTIC VERSION									

