

PART NUMBER	REVISION	DESCRIPTION	FEED TYPE
2150061-2	F	FINE CRIMP HEIGHT ADJUST	PNEUMATIC
7-2150061-2	F	PNEUMATIC AND CRIMP TOOLING KIT	PNEUMATIC
7-2150061-7	A	CRIMP TOOLING KIT	-

ATLANTIC VERSION TERMINATOR INTERFACE ADAPTER

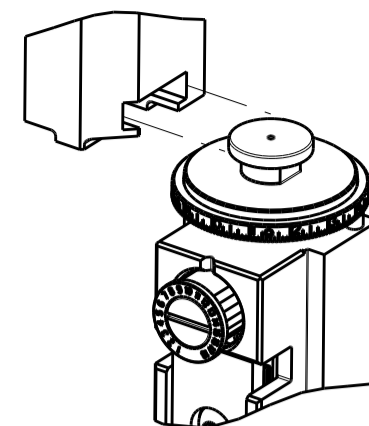

APPLICATOR DATA		
CRIMP	SIZE	TYPE
WIRE	2.79 mm [.110]	F
INSUL	4.32 mm [.170]	F
APPL INSTRUCTIONS 408-35043		

TERMINAL DATA: TE TERMINAL		TE CRIMP SPECIFICATION	
TERMINAL NAME: 250 SERIES POSITIVE LOCK MARK II RECEPT.			
WIRE STRIP LENGTH		INSULATION DIAMETER RANGE	
5.50-6.50 mm [.217-.256 IN]		∅2.20-3.40 mm [.087-.134 IN]	
TERMINAL APPLICATION SPECIFICATION	114-5042		
TERMINALS APPLIED			
TE TERMINAL	TE TERMINAL	TE TERMINAL	TE TERMINAL
170328-1	170328-3		

WIRE SIZE	CRIMP HEIGHT mm [INCH]	CRIMP HEIGHT REFERENCE SETTING
14 AWG OR 2.00mm2	1.82 +/- 0.05 [.072 +/- .002]	7.7
16 AWG OR 1.25mm2	1.62 +/- 0.05 [.064 +/- .002]	9.9
18 AWG OR 0.76mm2	1.55 +/- 0.05 [.061 +/- .002]	10.7
0.75mm2	1.50 +/- 0.05 [.059 +/- .002]	11.1



- RECOMMENDED SPARE PARTS
- REFER TO SUPPLIED INSTRUCTION SHEET FOR CLEANING, LUBRICATION AND STORAGE OF APPLICATOR.
- APPLY PART NUMBER 2-23419-6 LOCTITE TO THREADS OF ITEM 242. APPLY PART NUMBER 1-23419-5 LOCTITE TO THREADS OF ITEM 50.
- CRIMP HEIGHT REFERENCE SETTING WAS THE SETTING USED WHEN THE APPLICATOR WAS QUALIFIED AT THE FACTORY. ADJUSTMENT MAY BE NECESSARY WHEN RUNNING APPLICATOR IN THE FIELD.
- TERMINAL PITCH NOT COMPATIBLE WITH MECHANICAL FEED.
- UNLESS SPECIFIED OTHERWISE TORQUE VALUES SHALL BE USED PER DOCUMENT, 101-35000.
- TERMINAL LUBRICANT IS RECOMMENDED.

***WARNING**
ON INSTALLATION, SET WIRE DISC TO CRIMP HEIGHT REFERENCE SETTING FOR LARGEST WIRE SIZE. CRIMP HEIGHT REFERENCE SETTINGS GREATER THAN THE VALUE SHOWN MAY CAUSE DAMAGE TO THE CRIMP TOOLING. REFER TO THE INSTRUCTION SHEET FOR PROPER SETUP AND ADJUSTMENTS.

LOC	DIST	REVISIONS					
A	66	P	LTN	DESCRIPTION	DATE	DWN	APVD
		C1		ECR-19-010711	09JUL2019	FZ	GB
		D		ECR-20-004057	17MAR2020	TB	GB
		E		ECR-20-008019	04JUN2020	TB	RK
		F		ECR-20-009451	02JUL2020	FJ	GB

-	1	1	2119641-1	FEED CAM, AIR FEED	248	
-	1	1	2119082-9	CAM, SNAIL, INSULATION ADJUSTMENT	244	
-	1	1	2079764-1	WASHER, WAVE SPRING, CREST-TO-CREST	243	
-	1	1	2119083-1	RETAINER, INSULATION DIAL	242	
-	1	1	2844940-4	AIR FEED MODULE	238	
-	1	1	6-993111-6	PIN, SLOTTED SPRING 3.0 X 14.0	177	
-	1	1	8-22280-7	SPRING, COMPRESSION	176	
-	1	1	1752353-2	GUIDE PIN,HOLDDOWN	175	
-	1	1	1901680-2	GUIDE PIN,HOLDDOWN	174	
-	REF	REF	994970-2	COUNTER, MAGNETIC	164	
-	1	1	2119955-2	ASSY, LUBRICATOR, END FEED	84	
-	1	1	455888-4	SPACER, CRIMPER	82	
-	1	1	1803203-1	BLOCK, FRONT DEPRESSOR	77	
-	1	1	2119791-5	DEPRESSOR, WIRE	73	
-	1	1	1803607-4	DOCUMENTATION PACKAGE	71	
-	2	2	2-18032-2	SCR, SET, FLT PNT, M3 X 10.0	70	
-	1	1	2119943-1	WASHER, SPACER	69	
-	1	1	2119740-1	TAG, IDENTIFICATION	67	
-	2	2	2168078-1	SCREW, DRIVE, RH, RoHS, 2 x .188	66	
-	1	1	1976052-1	HOLDDOWN, TERMINAL	65	
-	4	4	2168400-8	SHCS, LOW HEAD, RoHS, M4 X 16	64	
-	1	1	2168083-2	SCR, SKT HD CAP, RoHS, M4 X 8.0	60	
-	1	1	5-18022-5	SCR, HEX HD CAP, M4 X 6.0	59	
-	1	1	2168400-4	SHCS, LOW HEAD, RoHS, M4 X 8	57	
-	2	2	2168083-8	SCR, SKT HD CAP, RoHS, M4 X 16	56	
-	2	2	5018030-1	NUT, HEX, REG, RoHS, M3	54	
-	2	2	986965-8	NUT, LOCK, HEX, TORQUE (M4)	53	
-	1	1	1-5018030-0	NUT, HEX, REG, RoHS, M3.5	52	
-	1	1	2063961-9	FEED FINGER	51	
-	1	1	1-1752354-2	STANDOFF,HOLD-DOWN	50	
-	1	1	18023-9	SCR, SKT HD CAP M4 X 6.0	49	
-	1	1	2119655-5	APPLICATOR BASIC ASSEMBLY, EF	46	
-	1	1	1803517-1	RAM ASSEMBLY, EF ATLANTIC	44	
-	1	1	1803602-1	SCR, BHSC, RoHS (M8 X 25)	41	
-	9	9	1-18028-2	WASHER, FLAT, REG M4	33	
-	2	2	2168083-9	SCR, SKT HD CAP, RoHS, M4 X 20	31	
-	2	2	2168083-2	SCR, SKT HD CAP, RoHS, M4 X 8.0	29	
-	1	1	240639-1	STRIPPER (MACHINING)	27	
-	2	2	1-2168083-5	SCR, SKT HD CAP, RoHS, M4 X 30	25	
-	1	1	1752371-1	PLATE, STRIP GUIDE	24	
-	1	1	2-240825-2	PLATE, STRIP HOLD DOWN	23	
-	2	2	22281-8	SPRING, COMPRESSION	22	
-	2	2	913774-2	GUIDE, DRAG	21	
-	1	1	1-1803292-0	DRAG	20	
-	2	2	1901259-5	GUIDE, LOWER STRIP	18	
-	4	4	1-2079383-1	SCR, BHSC, RoHS (M6 X 12)	17	
-	1	1	240641-2	SPACER	16	
-	1	1	1752360-1	SPACER,HOLD-DOWN	13	
-	1	1	240644-1	PLATE, REAR SHEAR	11	
-	-	-	-	-	10	
-	1	1	690482-4	PLATE, FRONT SHEAR	9	
-	1	2	1-1803000-4	ANVIL, COMBINATION, END FEED	8	
-	1	1	5-690474-3	BLADE, SLUG	7	
-	1	1	6-240641-2	SPACER	5	
-	1	1	2-238011-2	BLOCK, CRIMPER SPACER	4	
-	1	2	4-2119582-9	CRIMPER, INSULATION F PREMIUM	3	
-	1	1	1-455888-2	SPACER, CRIMPER	2	
-	1	2	456408-6	CRIMPER, WIRE PREMIUM	1	
-	77	72	-2	PART NO	DESCRIPTION	ITEM NO

ATLANTIC VERSION
Shown on sheets 1 of 4 & 2 of 4
(Pacific version shown on sheets 3 of 4 & 4 of 4)

DIMENSIONS:		TOLERANCES UNLESS OTHERWISE SPECIFIED:		DRAWING NO	
mm	0 PLC ±	1 PLC ±	2 PLC ±	3 PLC ±	4 PLC ±
	ANGLES ±	FINISH ±			
MATERIAL		FINISH		WEIGHT	
				A1 00779 C=2150061	
Customer Accessible Production Drawing				SCALE	SHEET 1 OF 4
				REV	F

LOC	DIST	REVISIONS					
A	66	P	LTM	DESCRIPTION	DATE	DWN	APVD
		-	-	SEE SHEET 1	-	-	-

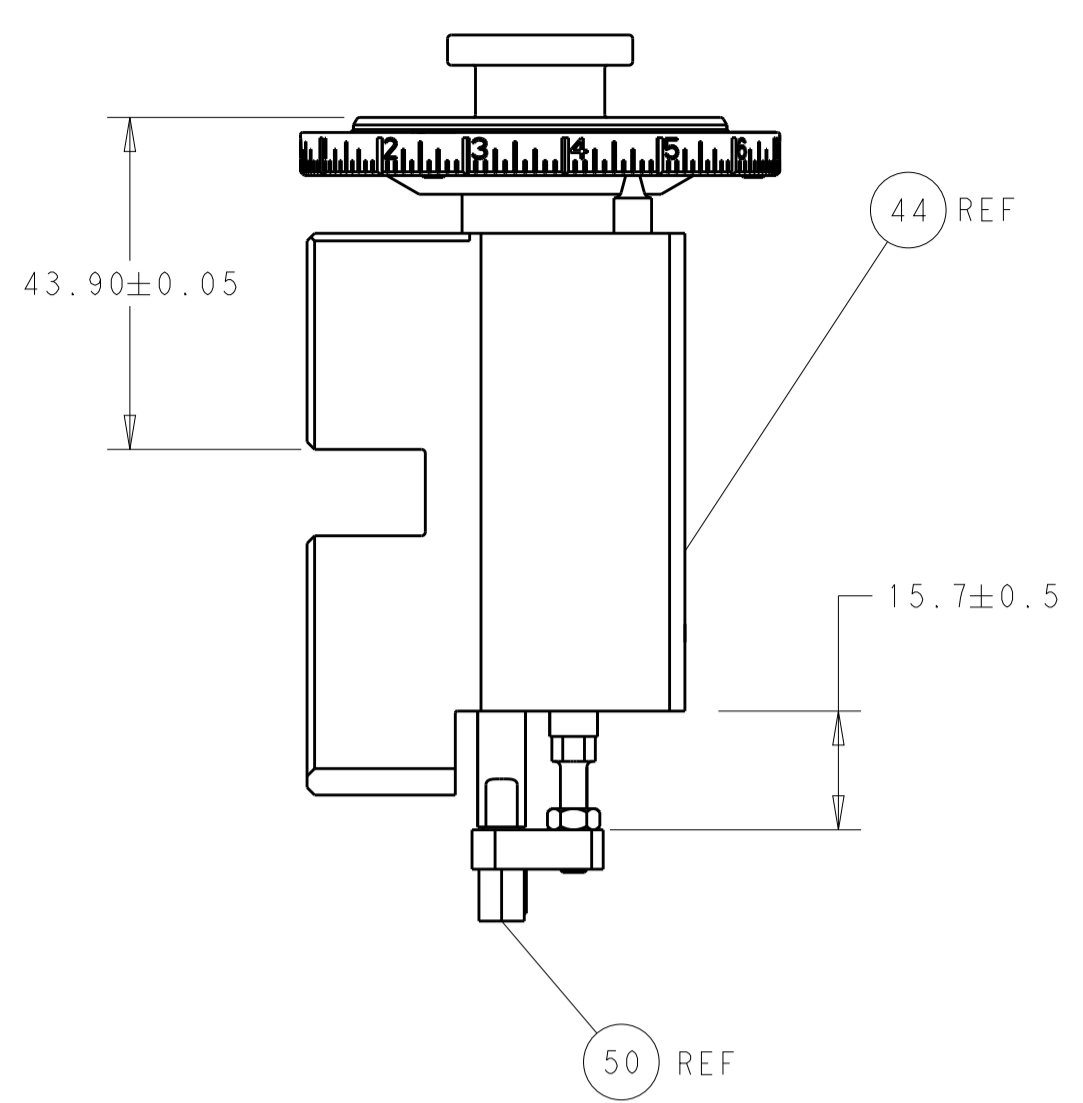

RAM AND HOLDDOWN SET-UP

FEED TYPE

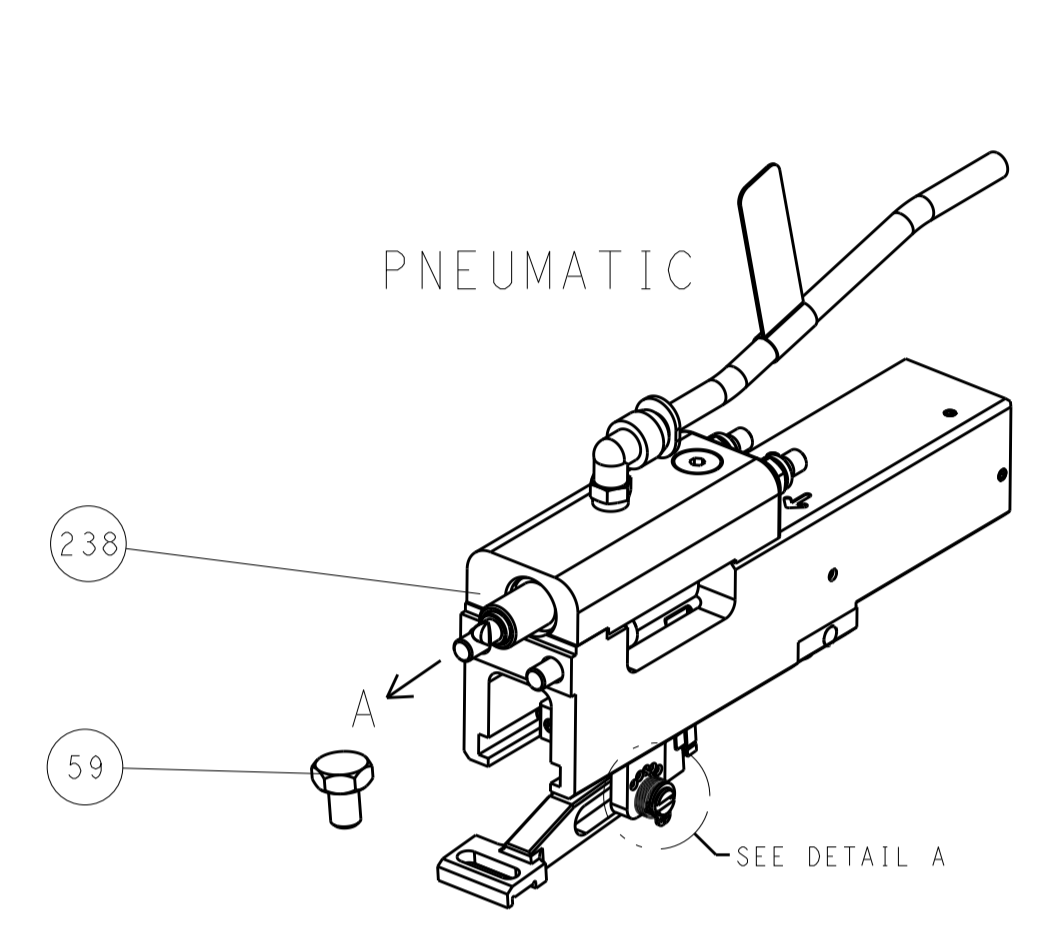

FEED SPRING SETTING POSITION

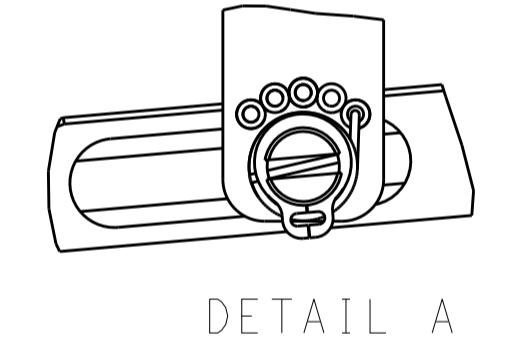

DETAIL A

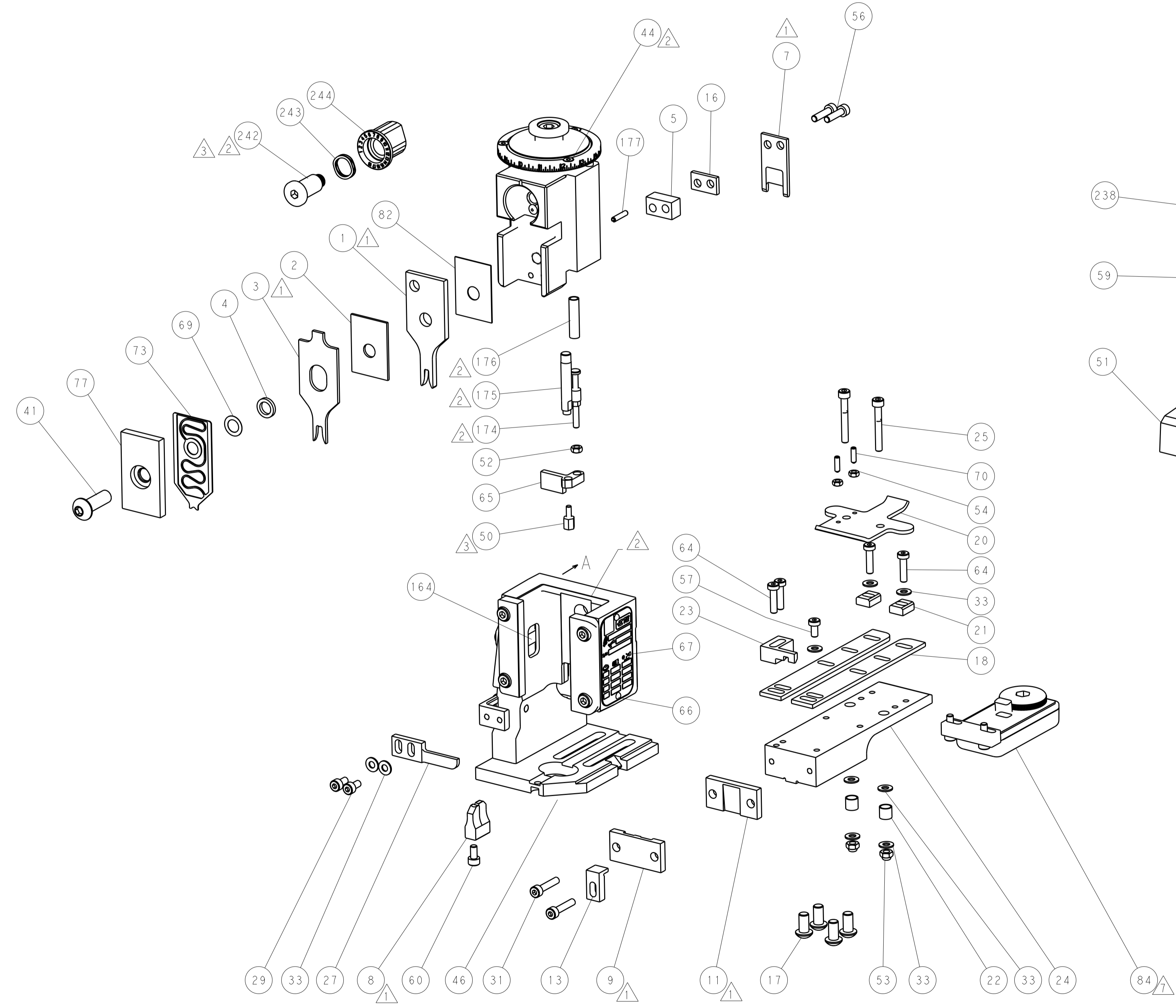

CAM POSITION

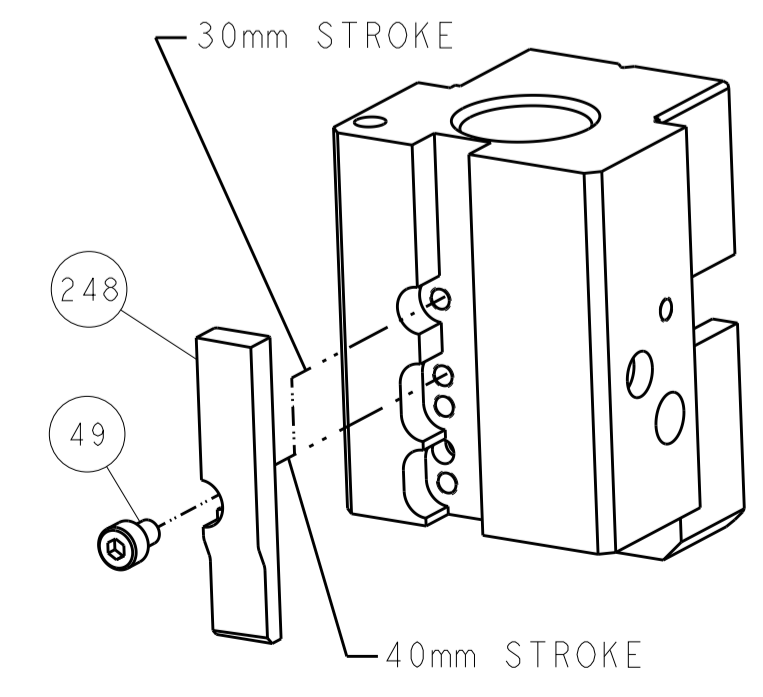

AIR FEED

ATLANTIC VERSION
 Shown on sheets 1 of 4 & 2 of 4
 (Pacific version shown on sheets 3 of 4 & 4 of 4)

<small>THIS DRAWING IS UNPUBLISHED. RELEASED FOR PUBLICATION BY TYCO ELECTRONICS CORPORATION. ALL RIGHTS RESERVED.</small>		DWN: K. STAKEM 20APR2012 CHK: G. BAILEY 20APR2012 APVD: T. ELBIN 20APR2012	TE Connectivity Harrisburg, PA 17105-3608
DIMENSIONS: mm 		TOLERANCES UNLESS OTHERWISE SPECIFIED: 0 PLC ± 1 PLC ± 2 PLC ± 3 PLC ± 4 PLC ± ANGLES ±	NAME: Ocean End Feed Applicator SIZE: A1 CAGE CODE: 00779 DRAWING NO: C=2150061 RESTRICTED TO: -
MATERIAL: - FINISH: -		WEIGHT: - SCALE: 1:1 SHEET: 2 OF 4 REV: F	CUSTOMER ACCESSIBLE PRODUCTION DRAWING

PART NUMBER	REVISION	DESCRIPTION	FEED TYPE
2-2150061-2	F	FINE CRIMP HEIGHT ADJUST	PNEUMATIC
7-2150061-7	A	CRIMP TOOLING KIT	-

PACIFIC VERSION TERMINATOR
 INTERFACE ADAPTER

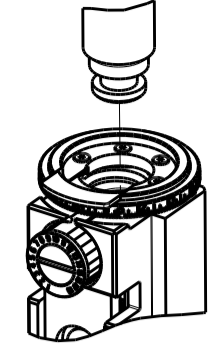

APPLICATOR DATA

CRIMP	SIZE	TYPE
WIRE	2.79 mm [1.10]	F
INSUL	4.32 mm [1.70]	F

APPL INSTRUCTIONS
 408-35043

TERMINAL DATA: TE TERMINAL TE CRIMP SPECIFICATION

TERMINAL NAME: 250 SERIES POSITIVE LOCK MARK II RECEPT.

WIRE STRIP LENGTH	INSULATION DIAMETER RANGE
5.50-6.50 mm [1.217-.256 IN]	∅2.20-3.40 mm [1.087-.134 IN]

TERMINAL APPLICATION SPECIFICATION

TERMINALS APPLIED

TE TERMINAL	TE TERMINAL	TE TERMINAL	TE TERMINAL
170328-1	170328-3		

WIRE SIZE	CRIMP HEIGHT mm [INCH]	CRIMP HEIGHT REFERENCE SETTING
14 AWG OR 2.00mm ²	1.82 +/- 0.05 [1.072 +/- .002]	7.7
16 AWG OR 1.25mm ²	1.62 +/- 0.05 [1.064 +/- .002]	9.9
18 AWG OR 0.76mm ²	1.55 +/- 0.05 [1.061 +/- .002]	10.7
0.75mm ²	1.50 +/- 0.05 [1.059 +/- .002]	11.1

- RECOMMENDED SPARE PARTS
- REFER TO SUPPLIED INSTRUCTION SHEET FOR CLEANING, LUBRICATION AND STORAGE OF APPLICATOR.
- APPLY PART NUMBER 2-23419-6 LOCTITE TO THREADS OF ITEM 242. APPLY PART NUMBER 1-23419-5 LOCTITE TO THREADS OF ITEM 50.
- CRIMP HEIGHT REFERENCE SETTING WAS THE SETTING USED WHEN THE APPLICATOR WAS QUALIFIED AT THE FACTORY. ADJUSTMENT MAY BE NECESSARY WHEN RUNNING APPLICATOR IN THE FIELD.
- TERMINAL PITCH NOT COMPATIBLE WITH MECHANICAL FEED.
- UNLESS SPECIFIED OTHERWISE TORQUE VALUES SHALL BE USED PER DOCUMENT, 101-35000.
- TERMINAL LUBRICANT IS RECOMMENDED.

***WARNING**
 ON INSTALLATION, SET WIRE DISC TO CRIMP HEIGHT REFERENCE SETTING FOR LARGEST WIRE SIZE. CRIMP HEIGHT REFERENCE SETTINGS GREATER THAN THE VALUE SHOWN MAY CAUSE DAMAGE TO THE CRIMP TOOLING. REFER TO THE INSTRUCTION SHEET FOR PROPER SETUP AND ADJUSTMENTS.

LOC	DIST	REV	DATE	BY	APPD
A	66				

REV	DATE	DESCRIPTION	DATE	BY	APPD
-	1	2119082-9 CAM, SNAIL, INSULATION ADJUSTMENT			244
-	1	2079764-1 WASHER, WAVE SPRING, CREST-TO-CREST			243
-	1	2119083-1 RETAINER, INSULATION DIAL			242
-	1	2844940-4 AIR FEED MODULE			238
-	4	2079383-9 SCR, BHSC, RoHS (M6 X 20)			186
-	1	6-993111-6 PIN, SLOTTED SPRING 3.0 X 14.0			177
-	1	8-22280-7 SPRING, COMPRESSION			176
-	1	1752353-2 GUIDE PIN, HOLDDOWN			175
-	1	1901680-2 GUIDE PIN, HOLDDOWN			174
-	REF	994970-2 COUNTER, MAGNETIC			164
-	1	2119641-2 FEED CAM, AIR FEED			152
-	1	2168083-8 SCR, SKT HD CAP, RoHS, M4 X 16			144
-	1	2119655-6 APPLICATOR BASIC ASSEMBLY, EF			141
-	1	1803518-1 RAM ASSEMBLY, EF PACIFIC			140
-	1	2119955-2 ASSY, LUBRICATOR, END FEED			84
-	1	455888-4 SPACER, CRIMPER			82
-	1	1803203-1 BLOCK, FRONT DEPRESSOR			77
-	1	2119791-5 DEPRESSOR, WIRE			73
-	1	1803607-4 DOCUMENTATION PACKAGE			71
-	2	2-18032-2 SCR, SET, FLT PNT, M3 X 10.0			70
-	1	2119943-1 WASHER, SPACER			69
-	1	2119740-1 TAG, IDENTIFICATION			67
-	2	2168078-1 SCREW, DRIVE, RH, RoHS, 2 x .188			66
-	1	1976052-1 HOLDDOWN, TERMINAL			65
-	4	2168400-8 SHCS, LOW HEAD, RoHS, M4 X 16			64
-	1	5-18022-5 SCR, HEX HD CAP, M4 X 6.0			59
-	1	2168400-4 SHCS, LOW HEAD, RoHS, M4 X 8			57
-	2	2168083-8 SCR, SKT HD CAP, RoHS, M4 X 16			56
-	2	5018030-1 NUT, HEX, REG, RoHS, M3			54
-	2	986965-8 NUT, LOCK, HEX, TORQUE (M4)			53
-	1	1-5018030-0 NUT, HEX, REG, RoHS, M3.5			52
-	1	2063961-9 FEED FINGER			51
-	1	1-1752354-2 STANDOFF, HOLD-DOWN			50
-	1	18023-9 SCR, SKT HD CAP M4 X 6.0			49
-	1	1803602-1 SCR, BHSC, RoHS (M8 X 25)			41
-	9	1-18028-2 WASHER, FLAT, REG M4			33
-	2	2168083-9 SCR, SKT HD CAP, RoHS, M4 X 20			31
-	2	2168083-2 SCR, SKT HD CAP, RoHS, M4 X 8.0			29
-	1	240639-1 STRIPPER (MACHINING)			27
-	2	1-2168083-5 SCR, SKT HD CAP, RoHS, M4 X 30			25
-	1	1752371-1 PLATE, STRIP GUIDE			24
-	1	2-240825-2 PLATE, STRIP HOLD DOWN			23
-	2	22281-8 SPRING, COMPRESSION			22
-	2	913774-2 GUIDE, DRAG			21
-	1	1-1803292-0 DRAG			20
-	2	1901259-5 GUIDE, LOWER STRIP			18
-	1	240641-2 SPACER			16
-	1	1752360-1 SPACER, HOLD-DOWN			13
-	1	240644-1 PLATE, REAR SHEAR			11
-	-	-			10
-	1	690482-4 PLATE, FRONT SHEAR			9
1	1	1-1803000-4 ANVIL, COMBINATION, END FEED			8
-	1	5-690474-3 BLADE, SLUG			7
-	1	6-240641-2 SPACER			5
-	1	2-238011-2 BLOCK, CRIMPER SPACER			4
1	1	4-2119582-9 CRIMPER, INSULATION F PREMIUM			3
-	1	1-455888-2 SPACER, CRIMPER			2
1	1	456408-6 CRIMPER, WIRE PREMIUM			1

PACIFIC VERSION
 Shown on sheets 3 of 4 & 4 of 4
 (Atlantic version shown on sheets 1 of 4 & 2 of 4)

DIMENSIONS: mm 		TOLERANCES UNLESS OTHERWISE SPECIFIED: 0 PLC ± 1 PLC ± 2 PLC ± 3 PLC ± 4 PLC ± ANGLES ± FINISH		DWN: H. STAKEM 20APR2012 CHK: G. BAILEY 20APR2012 APVD: T. ELBIN 20APR2012		NAME: Ocean End Feed Applicator SIZE: A1 CAGE CODE: 00779 DRAWING NO: 2150061 SCALE: 1:1 SHEET: 3 OF 4 REV: F	
MATERIAL: -		FINISH: -		WEIGHT: -		Customer Accessible Production Drawing	

LOC	DIST	REV	DATE	BY	APPV	
A	66					
REVISIONS			DESCRIPTION	DATE	DWN	APPV
			SEE SHEET 1			

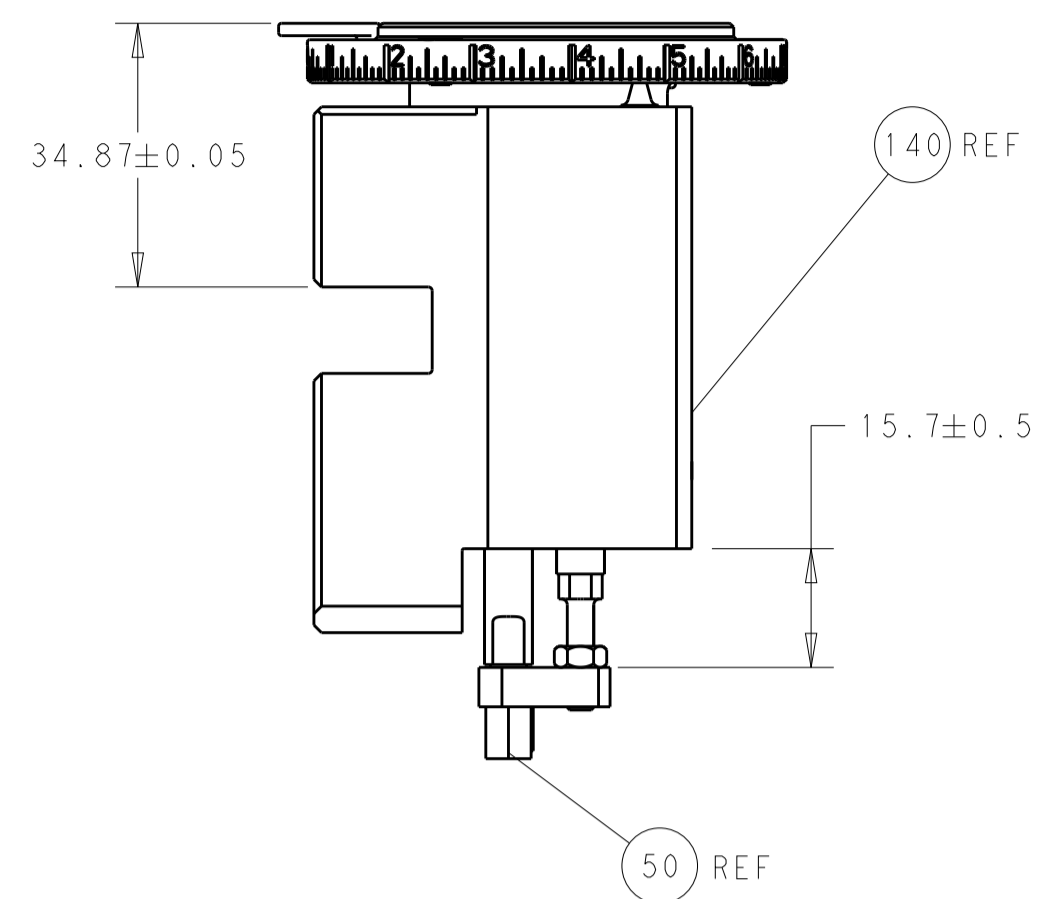

RAM AND HOLDDOWN SET-UP

FEED TYPE

PNEUMATIC

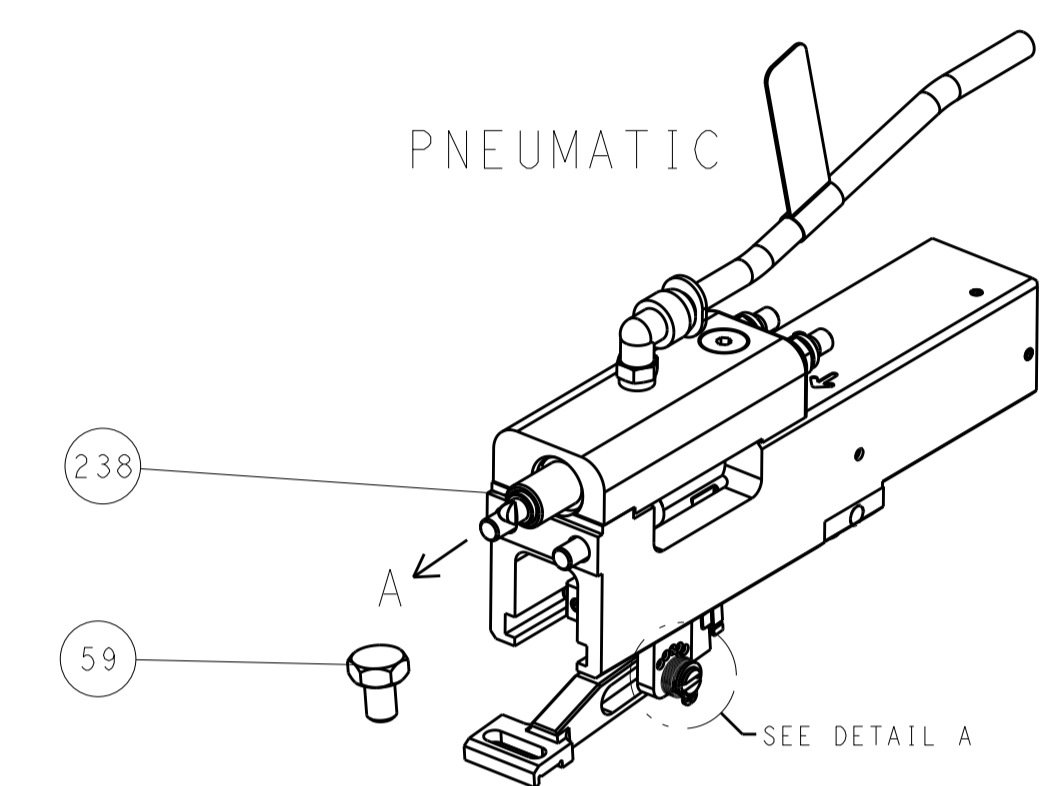

FEED SPRING SETTING POSITION

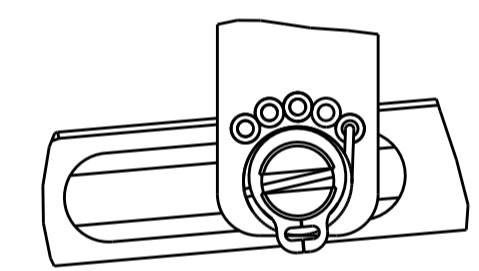

DETAIL A

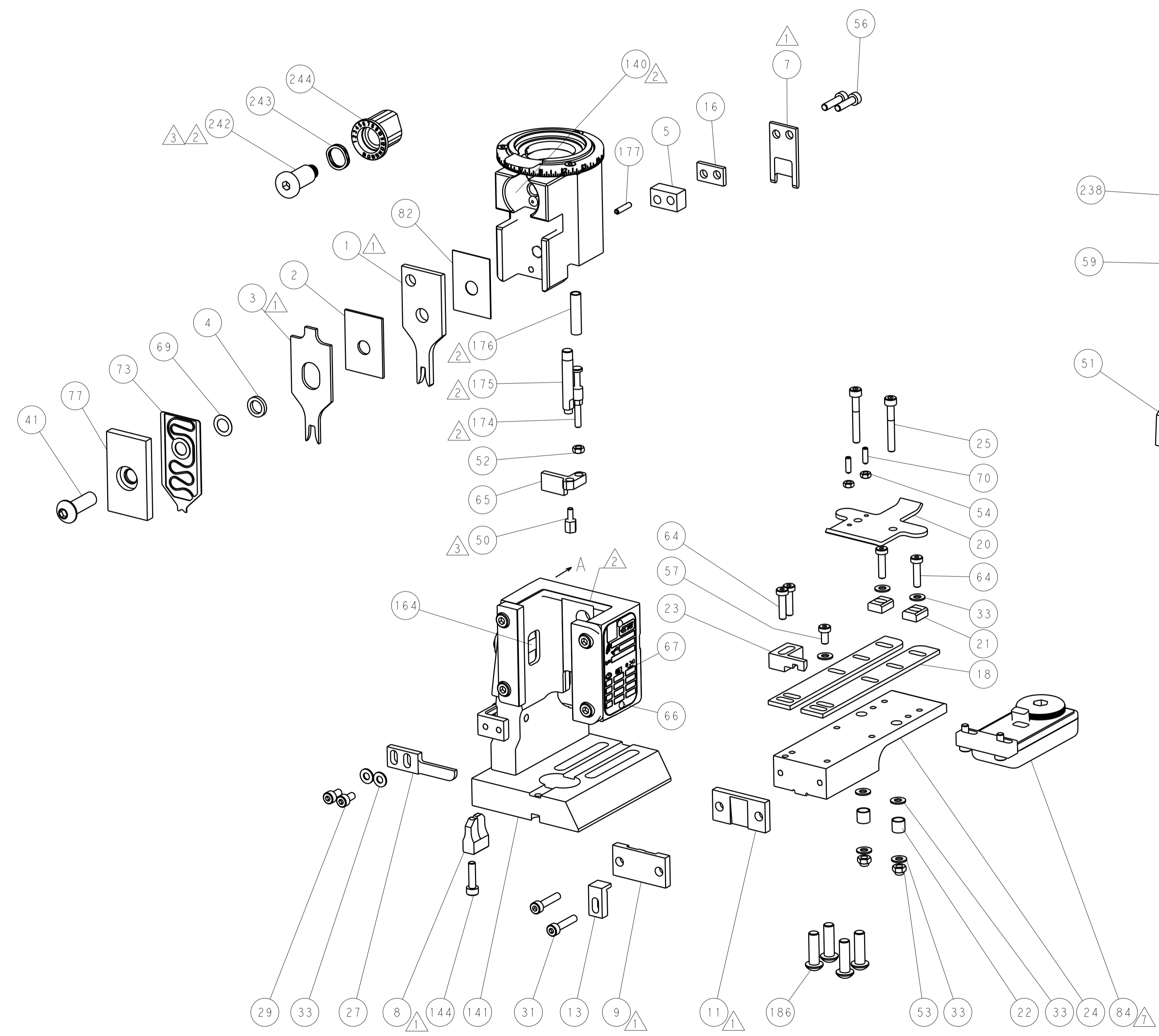

CAM POSITION

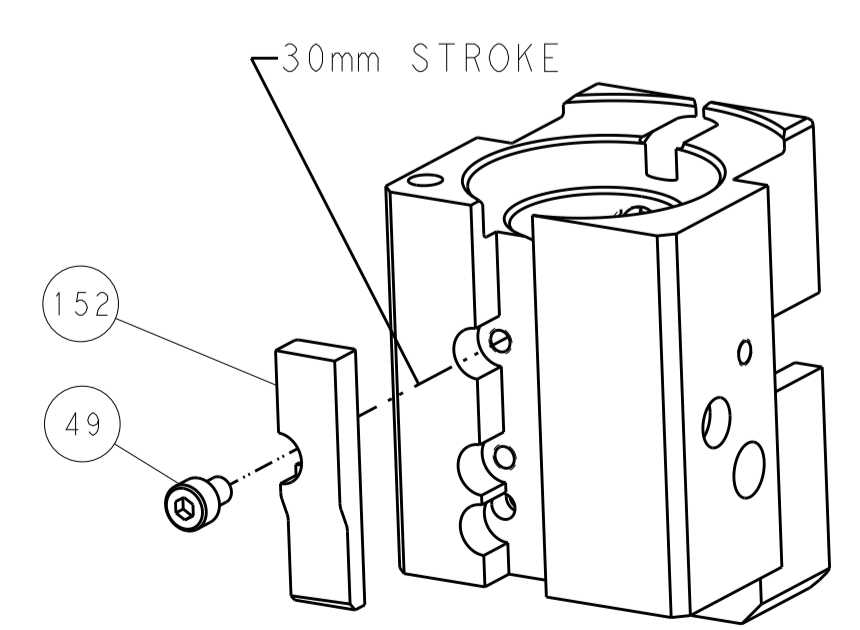

AIR FEED

PACIFIC VERSION
 Shown on sheets 3 of 4 & 4 of 4
 (Atlantic version shown on sheets 1 of 4 & 2 of 4)

<small>THIS DRAWING IS UNPUBLISHED. RELEASED FOR PUBLICATION BY TYCO ELECTRONICS CORPORATION. ALL RIGHTS RESERVED.</small>		DWN: K. STAKEM 20APR2012 CHK: G. BAILEY 20APR2012 APVD: T. ELBIN 20APR2012	TE Connectivity Harrisburg, PA 17105-3608
DIMENSIONS: mm TOLERANCES UNLESS OTHERWISE SPECIFIED: 0 PLC ± 1 PLC ± 2 PLC ± 3 PLC ± 4 PLC ± ANGLES ±		NAME: Ocean End Feed Applicator PRODUCT SPEC: APPLICATION SPEC: WEIGHT:	SIZE: A1 CAGE CODE: 00779 DRAWING NO: C=2150061 SCALE: 1:1 SHEET: 4 OF 4 REV: F
MATERIAL:		Customer Accessible Production Drawing	