

DLP5531-Q1 Light Engine Evaluation Module User's Guide

TI's DLP® technology offers the highest resolution available for automotive headlight applications and it's fully programmable. With more than one million addressable pixels per headlight, DLP technology exceeds the resolution of existing adaptive driving beam (ADB) technologies by several orders of magnitude. Automakers and Tier-1 suppliers can use this new programmable ADB solution to maximize brightness for drivers while minimizing the glare of oncoming traffic and reflections from high-gloss traffic signs. DLP technology works with any light source, including LED and laser illumination, and gives designers more precise light distribution on the road, with customizable beam patterns controlled by programmable software. Automakers and Tier-1 suppliers can partially or fully dim individual pixels with this solution, paving the way for the creation of headlight systems that allow drivers to keep their highbeams on in any condition.

The DLP5531-Q1 Light Engine Evaluation Module (EVM) allows for accelerated evaluation of the DLP5531-Q1 chipset with the inclusion of a DLP5531-Q1 light engine. This module brings together a set of components including the DLP5531-Q1, the DLPC230-Q1, and the TPS99000-Q1 to provide an efficient system for evaluation of high resolution headlight technology. When combined with an input video source and a computer or other means of control, the evaluation module can be used in a laboratory setting to demonstrate features such as:

- Adaptive Driving Beams
- Glare-Free Beam Steering
- Reflective Traffic Sign Dimming
- Pedestrian Dimming
- Symbol Projection
- OEM Branding

Contents

| | | |
|-----|---|----|
| 1 | DLP5531-Q1 Light Engine EVM Overview | 3 |
| 1.1 | What is in the DLP5531-Q1 Light Engine EVM..... | 3 |
| 1.2 | Non-Optical Specifications | 11 |
| 2 | Quick Start | 13 |
| 2.1 | Kit Assembly Instructions..... | 13 |
| 2.2 | Power-Up..... | 15 |
| 3 | LED Driver..... | 16 |
| 4 | Optics and Mechanics | 17 |
| 5 | Programming Flash Steps | 17 |
| 6 | SPI & I ² C Timing..... | 17 |

List of Figures

| | | |
|---|--|----|
| 1 | DLP5531-Q1 EVM Formatter Board | 5 |
| 2 | DLP5531-Q1 EVM LED Driver Board..... | 7 |
| 3 | Cables Included in DLP5531-Q1 Light Engine EVM..... | 9 |
| 4 | DLP5531-Q1 Light Engine EVM LED Driver Board Timing Specifications | 12 |
| 5 | Cable Connections | 14 |
| 6 | Assembled DLP5531-Q1 Light Engine EVM | 14 |
| 7 | Connecting to the DLPC230-Q1 Device Using the DLPC230-Q1 Automotive Control Program #1 | 15 |
| 8 | Connecting to the DLPC230-Q1 Device Using the DLPC230-Q1 Automotive Control Program #2 | 16 |

List of Tables

| | | |
|----|---|----|
| 1 | Formatter Board Ports | 4 |
| 2 | Formatter Board Switches | 4 |
| 3 | Formatter Board LED Indicators | 4 |
| 4 | LED Driver Board Ports | 6 |
| 5 | LED Driver Board Switches | 6 |
| 6 | Light Engine Performance Specifications | 8 |
| 7 | DLP5531-Q1 Light Engine EVM Cables..... | 9 |
| 8 | Electrical Specifications | 11 |
| 9 | EVM Components Which are Not Rated for –40°C to 105°C | 11 |
| 10 | LED Driver Board Timing Specifications | 12 |
| 11 | Typical Timing for Supported Source Resolutions..... | 13 |
| 12 | LED PWM Drive Current Conversion Reference..... | 16 |

Trademarks

DLP is a registered trademark of Texas Instruments.
All other trademarks are the property of their respective owners.

1 DLP5531-Q1 Light Engine EVM Overview

This user's guide presents an overview of the DLP5531-Q1 Light Engine EVM and a general description of the main features and functions. It will also provide first steps for getting started as well as a description of system functions and configurations.

1.1 What is in the DLP5531-Q1 Light Engine EVM

The DLP5531-Q1 Light Engine EVM consists of three subsystems:

- **Formatter Board** — Includes the DLP5531-Q1 DMD, the DLPC230-Q1 DMD Controller, and the TPS99000-Q1.
- **Illumination Driver Board** — Includes illumination drivers and provides power to the formatter board.
- **Light Engine** — Compact light engine designed to display images from the formatter board.

1.1.1 Formatter Board

The formatter board contains the following ports and switches, see [Figure 1](#).

Table 1. Formatter Board Ports

| SCHEMATIC REFERENCE | FUNCTION |
|---------------------|---|
| J1 | Host I ² C, PROJ_ON, HOLD_BOOT, HOST_IRQ |
| J2 | Host SPI |
| J3 | Micro HDMI |
| J4 | OpenLDI (Flex connector) |
| J5 | Photodiode 1 ⁽¹⁾ |
| J6 | TPS99000-Q1 SPI Debug |
| J7 | Photodiode 2 ⁽¹⁾ |
| J8 | HUD Driver Interface ⁽¹⁾ |
| J9 | LED Thermistor ⁽¹⁾ |
| J10 | Headlight Driver Interface |
| J11 | Formatter Power |

⁽¹⁾ Port unused for headlight application. Cable not provided.

Table 2. Formatter Board Switches

| SCHEMATIC REFERENCE / SIGNAL NUMBER | FUNCTION |
|-------------------------------------|--|
| SW1 (1) | Spread Spectrum Enable Off: Disabled On: Enabled |
| SW1 (2) | Test Point 2 Must be set to OFF position |
| SW2 (1) | Host Port Checksum Select Off: CRC On: Checksum |
| SW2 (2) | Host Interface Select Off: Host SPI On: Host I ² C |
| SW2 (3) | Host SPI Mode Off: Mode 0 or 3 On: Mode 1 or 2 |
| SW3 | Hold in Boot Off: Do not hold in boot (continue to main application) On: Hold in boot |
| SW4 | PROJ_ON Off: Turn off system On: Turn on system On state is to the left in Figure 1 |

Table 3. Formatter Board LED Indicators

| SCHEMATIC REFERENCE | FUNCTION |
|---------------------|--|
| D6 (Green) | Input power to Formatter Board (from LED Driver Board) Off: No power connected On: Power connected |
| D7 (Green) | PROJ_ON Off: System Off On: System On |
| D8 (Red) | HOST_IRQ Off: Interrupt not asserted On: Interrupt asserted |

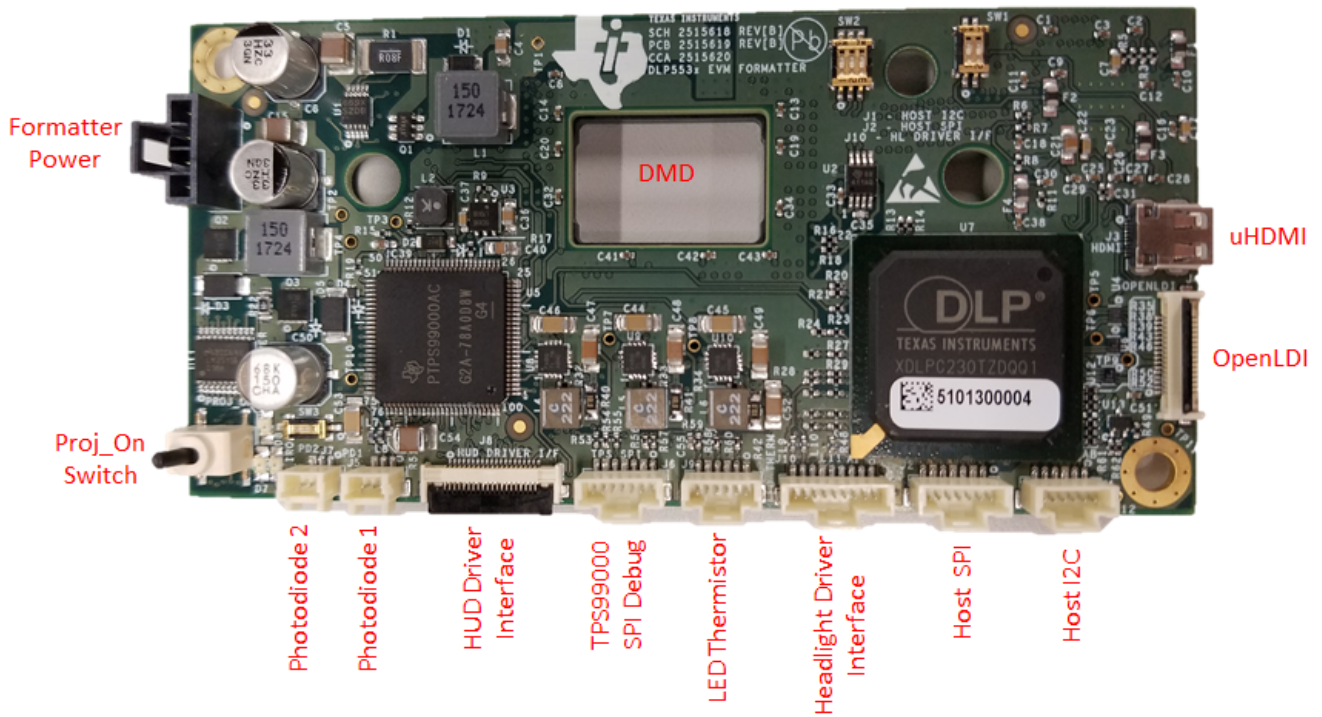



Figure 1. DLP5531-Q1 EVM Formatter Board

1.1.1.1 LED Driver Board

The headlight LED driver board contains the following ports and switches, see [Figure 2](#).

CAUTION



Hot surface. Contact may cause burns. Do not touch!

Table 4. LED Driver Board Ports

| SCHEMATIC REFERENCE | FUNCTION |
|---------------------|--|
| J1 | Formatter Power |
| J2 | Input Power |
| J3 | Fan |
| J4 | Fan |
| J5 | Headlight Driver Interface |
| J6 | Fan |
| J7 | LED 0 - High current output up to 6 A, locking and keyed connector |
| J8 | LED 1 - High current output up to 6 A, locking and keyed connector |
| J9 | LED 2 - High current output up to 6 A, locking and keyed connector |

Table 5. LED Driver Board Switches

| SCHEMATIC REFERENCE / SIGNAL NUMBER | FUNCTION |
|-------------------------------------|---|
| SW1 | Fan Enable On position is down in Figure 2 |

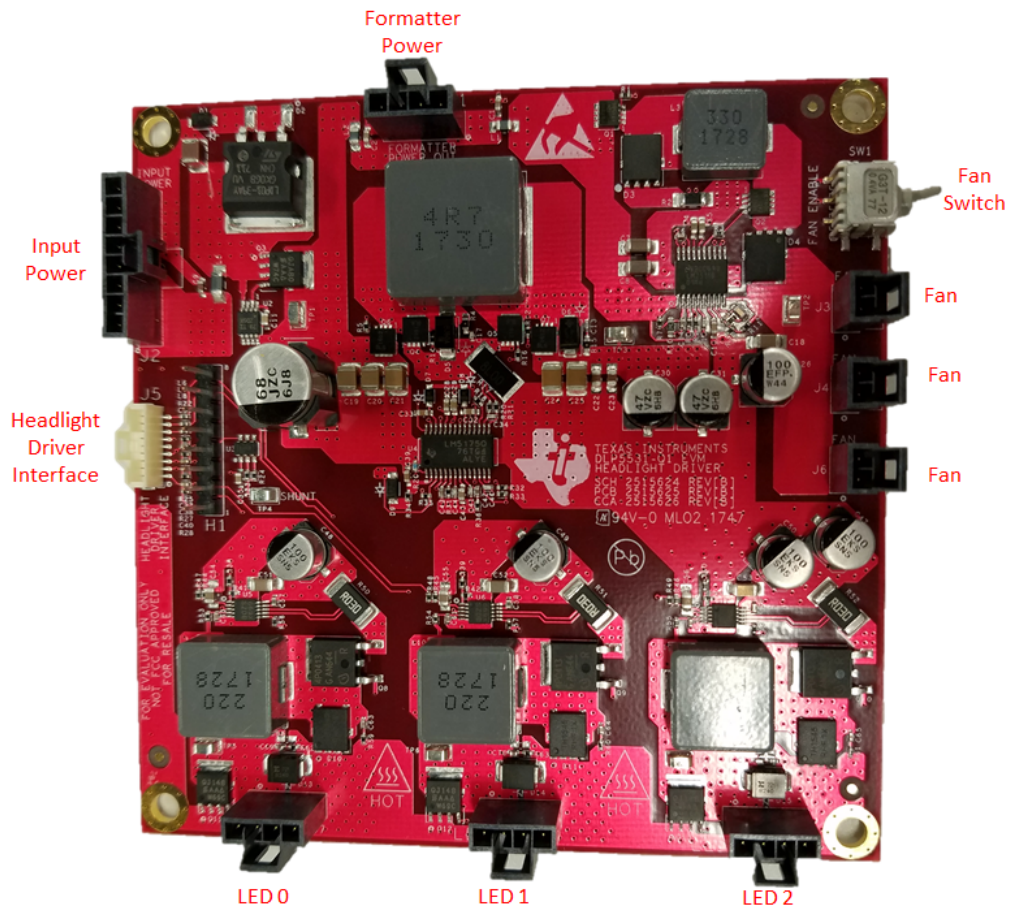

Figure 2. DLP5531-Q1 EVM LED Driver Board

1.1.2 EVM Light Engine

The light engine included with the DLP5531-Q1 Light Engine EVM can expect to achieve the specifications listed in [Table 6](#).

Table 6. Light Engine Performance Specifications

| PARAMETER | MIN | NOM | MAX | UNIT |
|---|-----|--------|-----|---------|
| Peak Lux at 25 m (measured at center of image) | | 120 | | lx |
| Full On/Full Off Contrast (measured at center of image) | | 300:1 | | |
| Field of View (FOV) | | 14 x 7 | | Degrees |

CAUTION



Caution Hot surface. Contact may cause burns. Do not touch!

CAUTION



Do not stare at operating lamp. May be harmful to the eyes.

1.1.3 Cables

The DLP5531-Q1 Light Engine EVM kit contains the following cables, see [Figure 3](#).

Table 7. DLP5531-Q1 Light Engine EVM Cables

| NAME | REFERENCE | QUANTITY |
|--|-----------|----------|
| Cheetah™ SPI Host Adapter | A | 1 |
| Host SPI Cable | B | 1 |
| Host I ² C Cable (Includes PROJ_ON, HOLD_BOOT, HOST_IRQ signals) | C | 1 |
| Headlight Driver Interface Cable | D | 1 |
| LED Power Cable | E | 1 |
| Formatter Power Cable | F | 1 |
| Input Power Cable | G | 1 |
| Micro HDMI Cable | H | 1 |
| OpenLDI Flex Cable | I | 1 |
| Fan Power Cable | J | 1 |



Figure 3. Cables Included in DLP5531-Q1 Light Engine EVM

NOTE: For the DLP5531-Q1 Light Engine EVM kit, the LED power cable (E) has been modified to connect to the LED in the DLP5531-Q1 light engine provided in the kit. Also, the loose fan power cables (J) have been removed in the DLP5531-Q1 Light Engine EVM kit, as the fan power cable is connected to the fan on the light engine.

1.2 Non-Optical Specifications

1.2.1 Electrical Specifications

Table 8. Electrical Specifications

| PARAMETER | MIN | NOM | MAX | UNIT |
|--|-----|-----|--------------------|------|
| INPUT | | | | |
| Voltage | 8 | 12 | 18 | V |
| Power | | | 96 | W |
| LED DRIVER OUTPUT LOAD | | | | |
| Voltage (Per LED Channel) | 3 | | 12 | V |
| Current (Per LED Channel) | | | 6 ⁽¹⁾ | A |
| Power (Sum of All LED Channels) | | | 72 | W |
| FAN LOAD | | | | |
| Voltage | | 12 | | V |
| Current (Sum of All Fan Channels) | | | 1 | A |
| TEMPERATURE | | | | |
| Operating DMD Temperature ⁽²⁾ | -40 | | 105 ⁽³⁾ | °C |

⁽¹⁾ 8 A may be used, but care must be taken to ensure that individual components and the PCB do not exceed their maximum temperature.

⁽²⁾ Care must be taken to ensure that individual components and PCB do not exceed their maximum temperature when driving high-power load.

⁽³⁾ Some components are only rated to 85°C. Refer to [Table 9](#) for a list of these components.

1.2.2 Component Temperature Ratings

The boards and most of the board components are rated to operate between -40°C to 105°C, including the DLP5531-Q1, the DLPC230-Q1, and the TPS99000-Q1.

Some components on board, such as switches, connectors, and indicator LEDs, do not meet this temperature rating. The specifications for all EVM components which are not rated between -40°C to 105°C are listed in [Table 9](#). Please refer to the EVM bill of materials to review the temperature specifications of all components used in the EVM design.

Table 9. EVM Components Which are Not Rated for -40°C to 105°C

| Board | Reference | Part Number | Manufacturer | Description | Temperature Minimum (°C) | Temperature Maximum (°C) |
|-----------|-------------------------|---------------|-----------------------|---------------------------------|--------------------------|--------------------------|
| Formatter | D6, D7 | LTST-C171KGKT | Lite-On | LED, GREEN 0805 | -55 | 85 |
| Formatter | D8 | LTST-C171KRKT | Lite-On | LED, RED 0805 | -55 | 85 |
| Formatter | J3 | 685119248123 | Würth | CONN MICRO HDMI RIGHT ANGLE | -40 | 85 |
| Formatter | SW1 | CVS-02TB | Copal Electronics Inc | SWITCH DIP SLIDE 2-POS 1 MM 6 V | -40 | 85 |
| Formatter | SW2 | CVS-03TB | Copal Electronics Inc | SWITCH DIP SLIDE 3-POS 1 MM 6 V | -40 | 85 |
| Formatter | SW3 | CVS-01TB | Copal Electronics Inc | SWITCH DIP SLIDE 1-POS 1 MM 6 V | -40 | 85 |
| Formatter | SW4 | GT12MSCBE | C&K Comp | SWITCH, SPST, GULL | -30 | 85 |
| Formatter | U4, U6, U12, U503, U505 | PCMF2HDMI2SZ | Nexperia | COMMON MODE CHOKE 4LN SMD ESD | -40 | 85 |

Table 9. EVM Components Which are Not Rated for –40°C to 105°C (continued)

| Board | Reference | Part Number | Manufacturer | Description | Temperature Minimum (°C) | Temperature Maximum (°C) |
|------------|-----------|----------------|-------------------|--------------------------------|--------------------------|--------------------------|
| Formatter | U504 | TFP401AIPZPRQ1 | Texas Instruments | IC PANELBUS DVI RCVR 100-HTQFP | –40 | 85 |
| LED Driver | SW1 | G3T12AH-R | NKK Switches | SWITCH, SPDT, 28 V, 100 mA | –30 | 85 |

The Formatter and LED Driver PCBs have a UL flame rating of 130°C maximum.

The DLP5531-Q1 Light Engine EVM is not a production design. It is intended for evaluation only.

1.2.3 Driver Requirements

The DLP5531-Q1 chipset, used with LED illumination, requires illumination modulation. This illumination modulation turns off the light output during micromirror reset, which improves system contrast. For the system timing specifications of the DLP5531-Q1 Light Engine EVM, see [Figure 4](#).

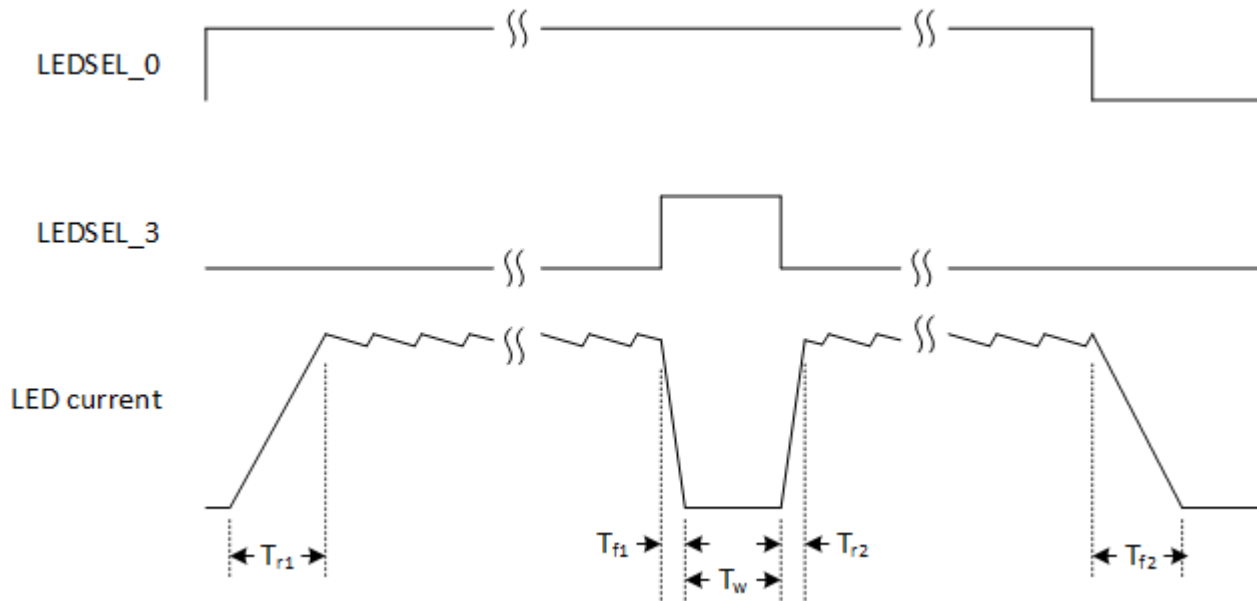

Figure 4. DLP5531-Q1 Light Engine EVM LED Driver Board Timing Specifications

The timing specifications are shown in [Table 10](#).

Table 10. LED Driver Board Timing Specifications

| PARAMETER | VALUE |
|------------------|---------------------|
| T_{r1}, T_{r2} | <50 μ s |
| T_{f1}, T_{f2} | <2 μ s |
| T_w | minimum = 1 μ s |

1.2.4 Video Specifications

The following resolutions are programmed in the Extended Display Identification Data (EDID). Some video sources may not support all resolutions.

- 1152 × 1152
- 1152 × 576
- 576 × 288

The input source specifications in the EDID of the EVM are outlined in [Table 11](#).

Table 11. Typical Timing for Supported Source Resolutions

| Horizontal Resolution | Vertical Resolution | Horizontal Blanking | | | | Vertical Blanking | | | | Vertical Rate (Hz) | Pixel Clock (MHz) |
|-----------------------|---------------------|---------------------|---------------------|---------------------------|----------------------------|-------------------|--------------|--------------------|---------------------|--------------------|-------------------|
| | | Total | Sync (Pixel Clocks) | Back Porch (Pixel Clocks) | Front Porch (Pixel Clocks) | Total | Sync (Lines) | Back Porch (Lines) | Front Porch (Lines) | | |
| 1152 | 1152 | 80 | 8 | 32 | 40 | 33 | 8 | 22 | 3 | 60 | 87.59 |
| 1152 | 576 | 80 | 8 | 32 | 40 | 17 | 8 | 6 | 3 | 60 | 43.83 |
| 576 | 288 | 322 | 8 | 154 | 160 | 181 | 8 | 158 | 15 | 59.98 | 25.26 |

2 Quick Start

Use the following instructions to setup your DLP5531-Q1 Light Engine EVM and PC.

2.1 Kit Assembly Instructions

When assembling the DLP5531-Q1 Light Engine EVM, it is helpful to start by connecting the cables to the formatter board (attached to the light engine) to the LED driver board. Once all of the cables are connected, the light engine can be mounted. To mount the light engine, attach the light engine to the light engine stand. After the light engine is mounted on the stand, the stand can be mounted on the mounting plate of the LED driver board. A diagram of all connections is shown in [Figure 5](#). The full light engine assembly is shown in [Figure 6](#).

1. Connect the Headlight Driver Interface cable to the Formatter Board (J10) and the LED Driver Board (J5).
2. Connect the Host SPI cable to the Formatter Board (J2) and the Cheetah adapter. Connect the Cheetah adapter's USB cable to PC.
3. Connect the Formatter Power cable to the Formatter Board (J11) and the LED Driver Board (J1).
4. Connect the LED power cable to the LED Driver Board LED2 port (J9). The LED connector is located between the heat pipes and heat sink of the DMD. This connector is above the formatter board.
5. Connect the Fan Power cable to any of the LED Driver Board fan ports (J3, J5, J6). Confirm the fan switch on the LED Driver Board (SW1) is in the ON position.
6. Connect the Micro HDMI cable to the Formatter Board (J3). Connect the Micro HDMI cable to PC HDMI port.
7. Connect the Power Input cable to the LED Driver Board (J2).

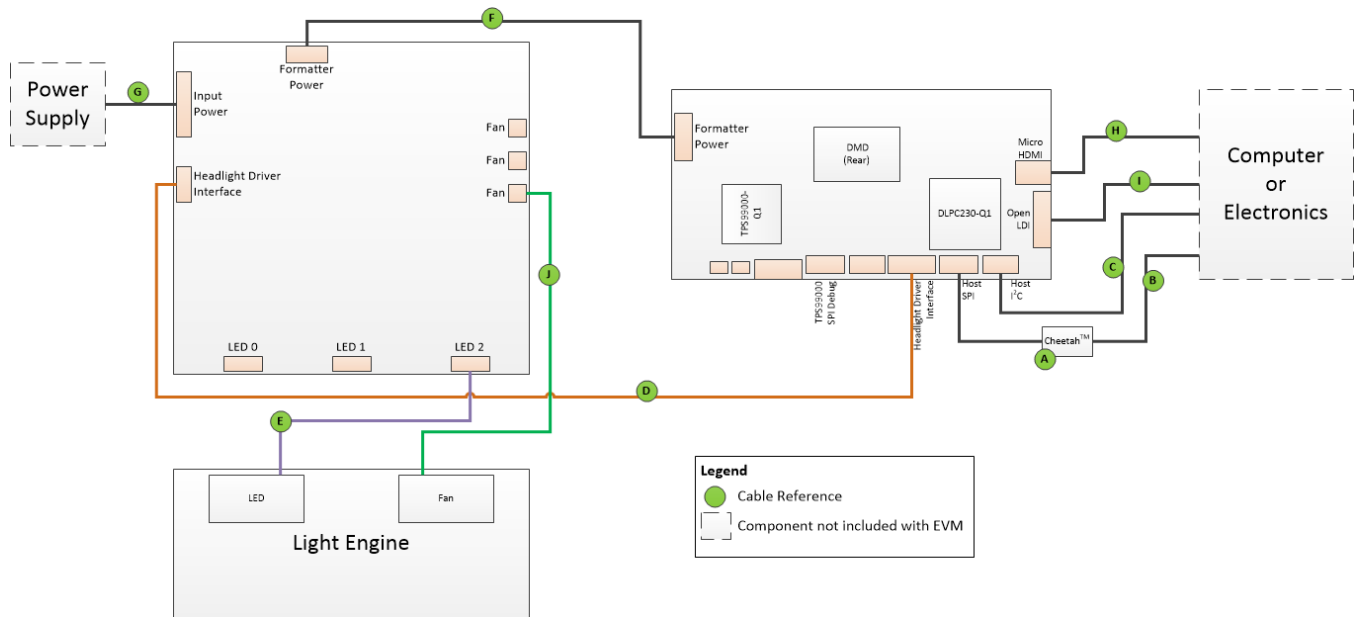

Figure 5. Cable Connections

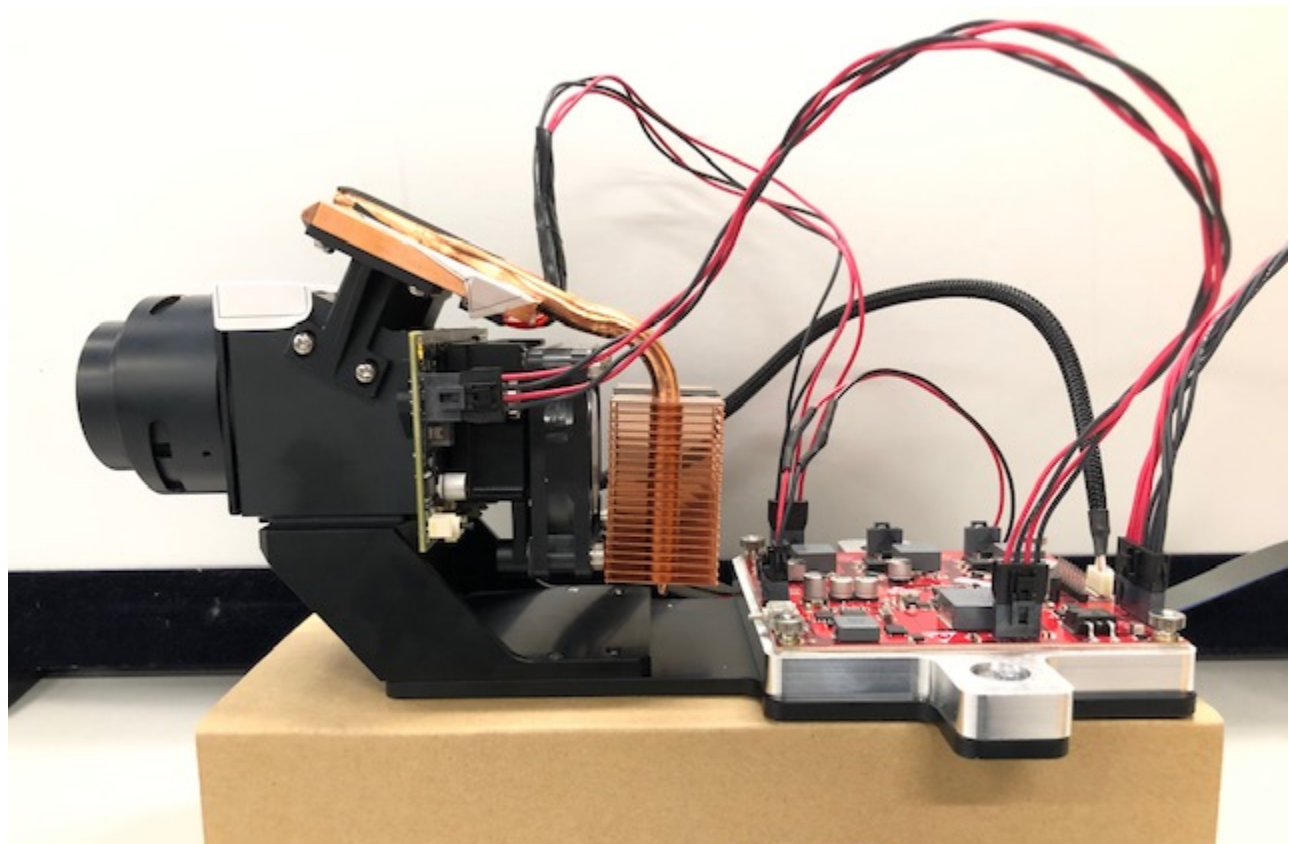

Figure 6. Assembled DLP5531-Q1 Light Engine EVM

2.2 Power-Up

1. Connect input power cable to a power supply that meets input power specifications defined in [Section 1.2](#). The red cable for the V+ terminal and black cable for the V- terminal.
2. Turn on the supply power. Once powered up, a Formatter Board LED indicator (D6) should illuminate green.
3. Turn the PROJ_ON switch (SW4) ON. The ON position is towards the perimeter of the board, and OFF is towards the DMD. A Formatter Board LED indicator (D7) should illuminate green.

2.2.1 Software Setup

1. Download and install the DLPC230-Q1 Control Program (<https://www.ti.com/mysecuresoftware>).
2. Install Total Phase Cheetah USB adapter (<http://www.totalphase.com/products/usb-driverswindows>).
3. Use the DLPC230-Q1 Control Program to connect to the system using the Cheetah USB to SPI adapter and turn the system on.
4. To connect, set the DLPC230-Q1 Host to SPI and select the Cheetah from the drop down menu.

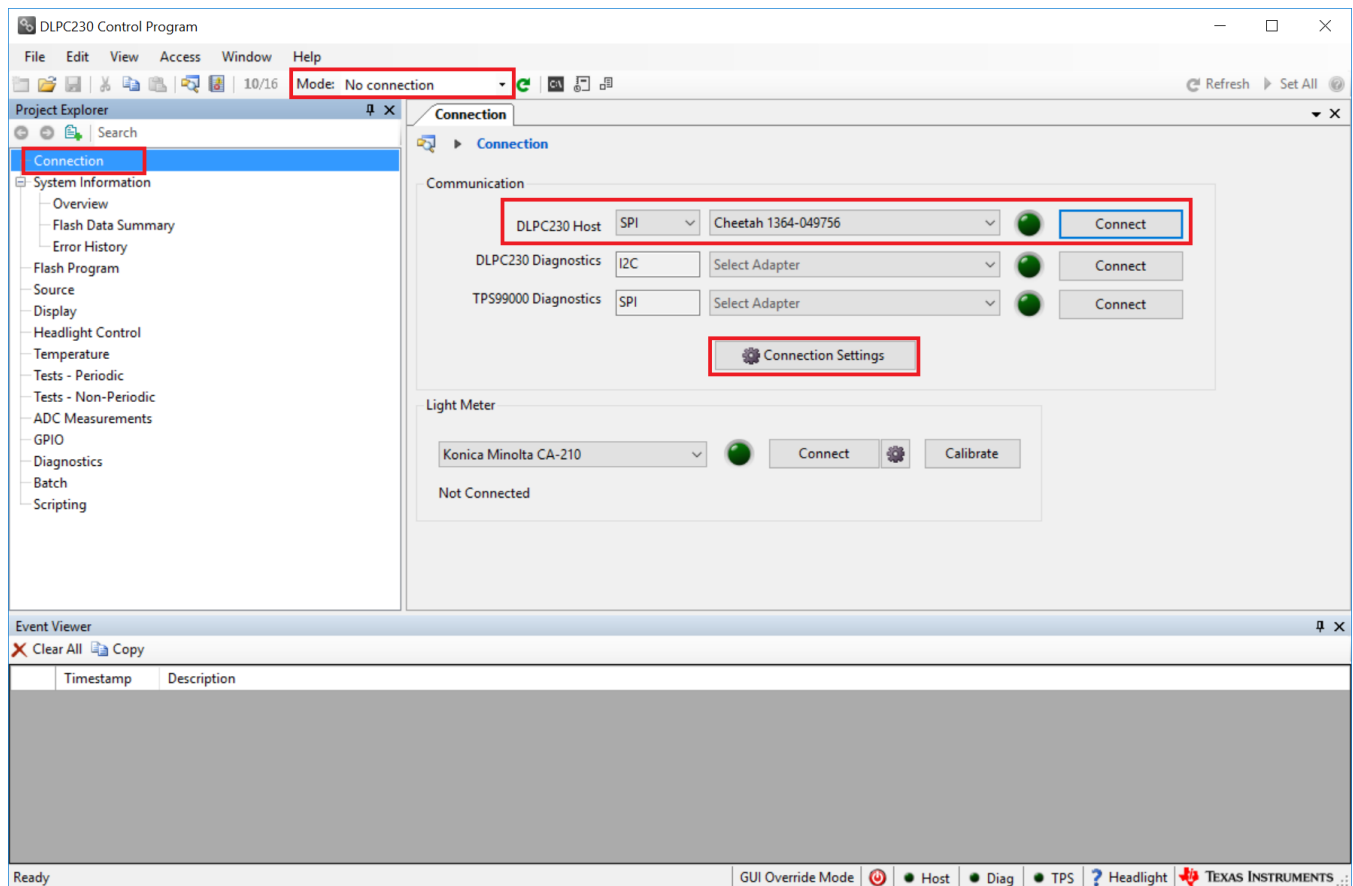

Figure 7. Connecting to the DLPC230-Q1 Device Using the DLPC230-Q1 Automotive Control Program #1

5. Select "Connection Settings" to confirm the SPI configuration matches the Formatter Board switch settings described in [Table 2](#). Specifically, SPI mode and CRC/Checksum may vary based on switch settings. Press "OK" once configuration is complete.

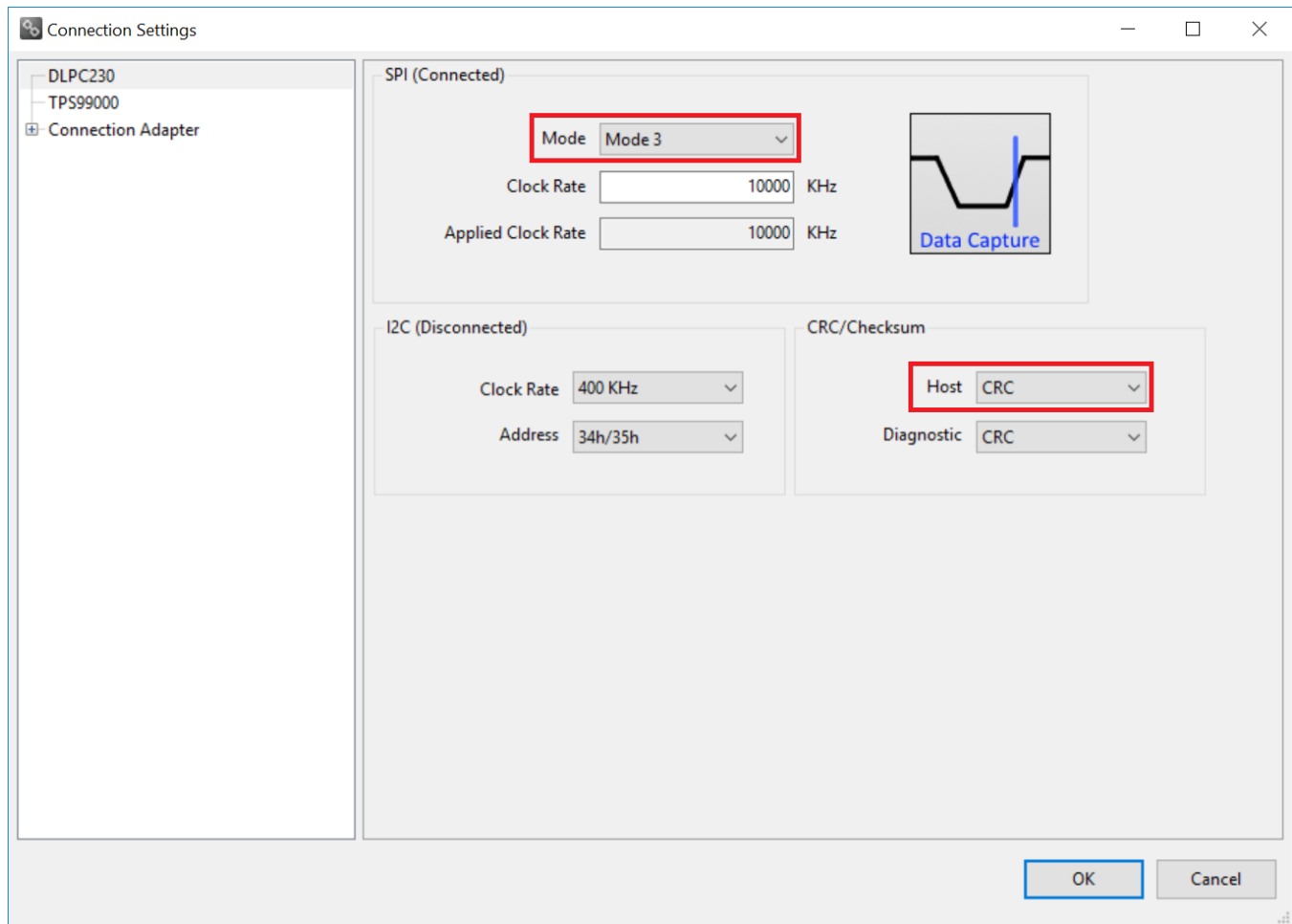

Figure 8. Connecting to the DLPC230-Q1 Device Using the DLPC230-Q1 Automotive Control Program #2

6. Click the Connect button. The green circle should then light up to indicate that connection was successful to the Cheetah Adapter.

3 LED Driver

Section 1.2 defines the LED driver load specifications.

The LED brightness can be controlled through PWM output from the DLPC230-Q1. Using the DLPC230-Q1 Automotive Control Program "Headlight Control" tab, the PWM slider bars (PWM0, PWM1, and PWM2) control the current through each LED driver channel. Note that the PWM control may exceed the maximum current specification of some LEDs in certain LED configurations. Table 12 provides reference conversions from PWM level to drive current for commonly used current levels. The LED used in the DLP5531-Q1 Light Engine EVM has a maximum current rating of 6 A. Because of this maximum current (6 A), the user of the DLP5531-Q1 Light Engine EVM must not set the PWM level over 768. If the user selects a PWM value over 768, the LED can be permanently damaged.

Table 12. LED PWM Drive Current Conversion Reference

| PWM LEVEL | DRIVE CURRENT (A) |
|-----------|--------------------|
| 0 | See ⁽¹⁾ |
| 256 | 2 |
| 512 | 4 |

⁽¹⁾ Some current will continue to flow through the LED with a PWM level of 0 and light output may still be visible. To fully remove LED current, the system must be set to standby mode.

Table 12. LED PWM Drive Current Conversion Reference (continued)

| PWM LEVEL | DRIVE CURRENT (A) |
|-----------|-------------------|
| 768 | 6 |
| 1024 | 8 |

4 Optics and Mechanics

Both optics and recommended heat sinks (DMD and LED) are included with the DLP5531-Q1 Light Engine EVM. These heat sinks have been designed to operate the DLP5531-Q1 DMD and LED within their data sheet specifications.

5 Programming Flash Steps

1. Using the DLPC230-Q1 Automotive Control Program, which is connected to the EVM, navigate to the "Flash Program" tab.
2. Using the folder icon, select an Image File (.bin) and open it.
3. Click "Program and Verify Flash Memory."

Note that if the device is in Display mode, it will automatically be switched to Standby during programming.

6 SPI & I²C Timing

For more information on SPI and I²C specifications, see the DLPC230-Q1 data sheet.

Revision History

NOTE: Page numbers for previous revisions may differ from page numbers in the current version.

| Changes from Original (December 2019) to A Revision | Page |
|---|-------------|
| • Added maximum PWM value to achieve maximum current for LED used in Light Engine | 16 |

IMPORTANT NOTICE AND DISCLAIMER

TI PROVIDES TECHNICAL AND RELIABILITY DATA (INCLUDING DATASHEETS), DESIGN RESOURCES (INCLUDING REFERENCE DESIGNS), APPLICATION OR OTHER DESIGN ADVICE, WEB TOOLS, SAFETY INFORMATION, AND OTHER RESOURCES "AS IS" AND WITH ALL FAULTS, AND DISCLAIMS ALL WARRANTIES, EXPRESS AND IMPLIED, INCLUDING WITHOUT LIMITATION ANY IMPLIED WARRANTIES OF MERCHANTABILITY, FITNESS FOR A PARTICULAR PURPOSE OR NON-INFRINGEMENT OF THIRD PARTY INTELLECTUAL PROPERTY RIGHTS.

These resources are intended for skilled developers designing with TI products. You are solely responsible for (1) selecting the appropriate TI products for your application, (2) designing, validating and testing your application, and (3) ensuring your application meets applicable standards, and any other safety, security, or other requirements. These resources are subject to change without notice. TI grants you permission to use these resources only for development of an application that uses the TI products described in the resource. Other reproduction and display of these resources is prohibited. No license is granted to any other TI intellectual property right or to any third party intellectual property right. TI disclaims responsibility for, and you will fully indemnify TI and its representatives against, any claims, damages, costs, losses, and liabilities arising out of your use of these resources.

TI's products are provided subject to TI's Terms of Sale (www.ti.com/legal/termsofsale.html) or other applicable terms available either on ti.com or provided in conjunction with such TI products. TI's provision of these resources does not expand or otherwise alter TI's applicable warranties or warranty disclaimers for TI products.

Mailing Address: Texas Instruments, Post Office Box 655303, Dallas, Texas 75265
Copyright © 2020, Texas Instruments Incorporated